



ELOCLEAN

Automated pipe cleaning system

INSTALLATION AND USER MANUAL

IMA 200 130 R2C

ENGLISH

1. INTRODUCTION

1.1. ELOCLEAN

The device is developed for simple and safe cleaning of pipelines for Elotec Aspect ASD systems by use of air.

A powerful fan has been selected to blow dust out of the pipes – no compressor is required.

1.2. PACKAGE CONTENTS

- 1 pc. ELOCLEAN unit
- 1 pc. THUB for Aspect, 2-6
- 2 pc. external ball valves
- 4 pc. pipe stubs with threads
- 2 pc. extended T-joins
- 1 pc. 10,8 V lithium battery



1.3. FUNCTION

The cleaning process is initiated automatically at set intervals. As default, this occurs every 7 days, but the interval may be adjusted from 1 to 7 days.

The exact time for the automated cleaning is set at power-on, or on programming a custom interval.

Additionally, the process can be started manually – this will not affect set intervals / times for automatic cleaning.

EloClean will clean area 1 first, then area 2. The procedure takes approximately 3 minutes.

Before the pipe is blown clean, the external valve between EloClean and Aspect is closed to protect the ASD, and cleaning only proceeds if the valve is confirmed closed.

1.4. APPLICATIONS

EloClean is intended for installations with extreme amounts of dust where one can observe dust accumulating in the pipelines or in the sampling holes so that the airflow to Aspect is reduced.

Examples of such environments could be

- Poultry stables
- Paper waste treatment plants
- Storage facilities for grain / flour / feed pellets etc.

2. INTERFACE AND OPERATION

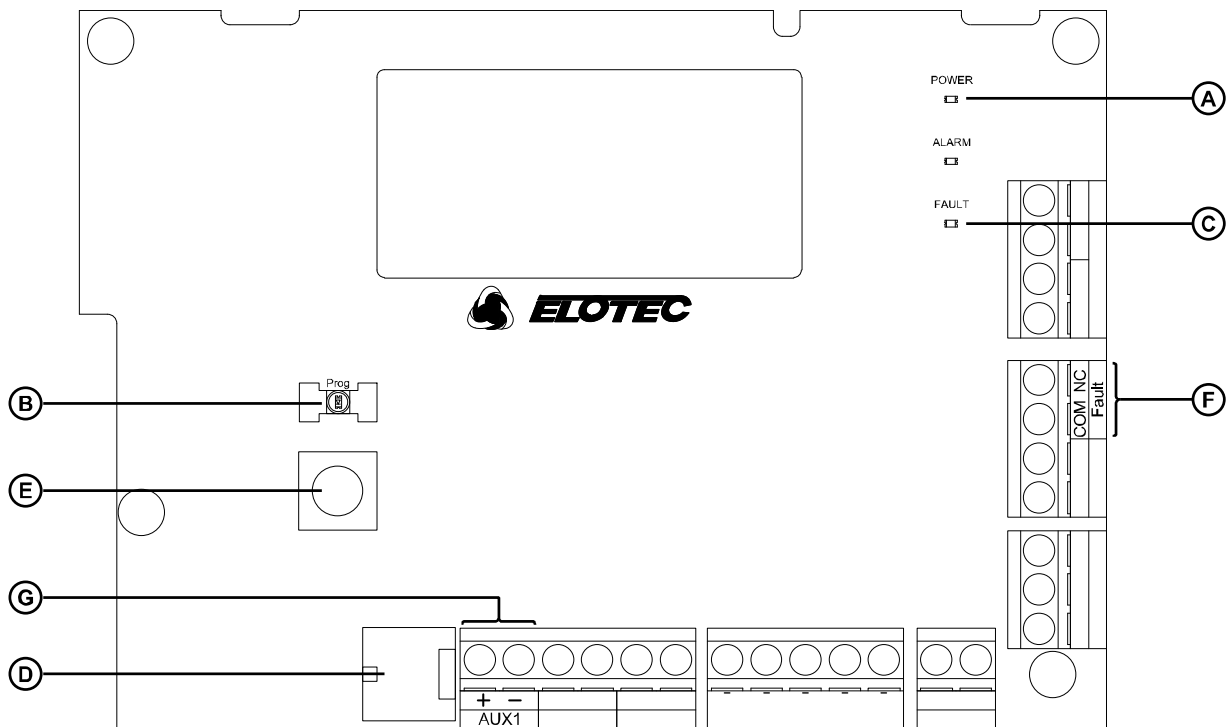

2.1. INDICATIONS

- A.** Green status LED:
- Constant: Normal.*
 - Flashes once per second: Cleaning in progress.*
 - Flashes 4 times per second: Cleaning postponed due to fault.*
- B.** Blue status LED:
- Constant: Programming in process.*
- C.** Yellow fault LED (priority view)
- Constant: Jammed valve.*
 - Flashes once per second: Low voltage, internal battery.*
 - Flashes 4 times per second: Supply fault (internal 12V) – auto reset on external power restore.*
- D.** Internal buzzer
- Pulsating tone in fault condition.*

2.2. BUTTONS

- E.** EloClean has one simple button for operating. This button is placed on the CPU board inside the device. The button has varying functions depending on how long it is operated and the state of the EloClean.

In the normal state:

- *Short press* – manual start of cleaning procedure.
- *Long press (>5 seconds)* – start programming.

In the fault or alarm state:

- *Short press* – acknowledge event (stops the internal buzzer).

2.3. OUTPUTS

- F.** 1 pc. fault relay, NC, fail-to-safe.

2.4. INPUTS

- G.** 1 pc. input for remote control of the cleaning procedure. This enables controlling EloClean from an external impulse switch or from a fire alarm panel through I/O. Short the input to initiate cleaning.

3. INSTALLATION AND SETUP

3.1. MOUNTING ON WALL

For use with both pipelines on Aspect, it is recommended to install EloClean directly underneath Aspect as shown in the picture below. If VULCAN dust- and condensation separator is used in the installation, external valves and pipes from EloClean shall be moved to the outside of the VULCAN units.



For use with only one pipeline, EloClean can be installed right next to Aspect, by using the pipe entry on the side of the THUB. The external valve must be situated between Aspect and EloClean.



External valves must be installed to protect the Aspect – the air pressure from EloClean may damage sensitive components in the Aspect if the Aspect pipe entry is not closed. EloClean will not start cleaning until the valve is confirmed closed.

For installation of external valves, pipe stubs with threads that fit the valve are included in the package. The other end of the stub can be cut to the desired length for THUB / branches / joins etc.

3.2. CONNECTIONS

3.2.1. External valves

External valves connect to terminals in the upper right inside EloClean. There are four leads per valve/area. Terminals are labelled according to area, and coloured leads shall be matched against colours on the terminal block.

Sequence from left to right is red, black, green, white – first area 1, then area 2.



NB! Even if EloClean is used for cleaning only one pipeline, both valves must be connected.

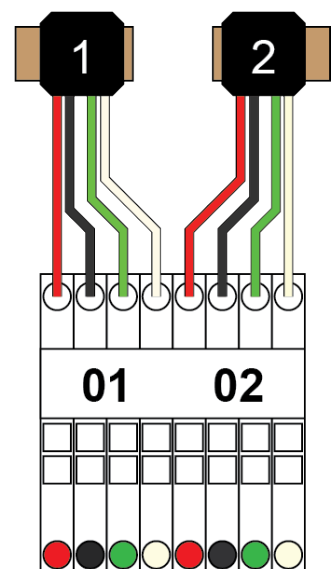

3.2.2. Fault output

A fault relay is available on the right-hand side of the CPU board. The relay is normally closed, and opens in case of a fault, or if power is lost.

The fault relay can be connected to the Aux input of AE2010 if no directly wired disabling button or external PSU is used. The input must be configured as a general fault input (P3=1).

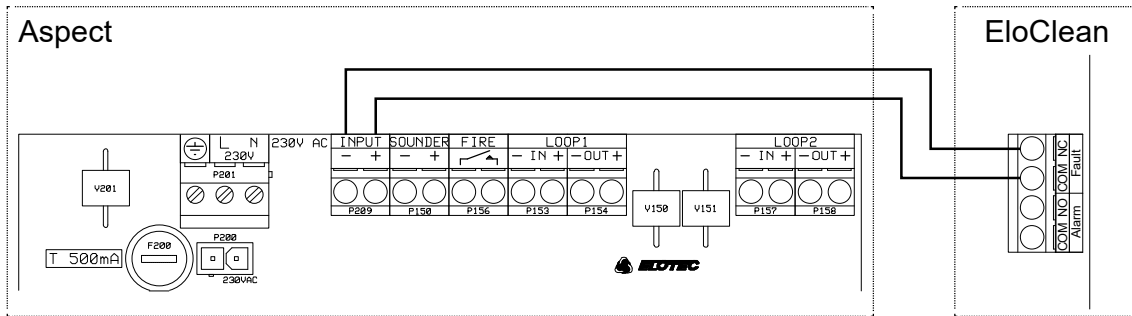

3.2.3. Power supply

Connect 230 V mains on the right-hand side of the mains filter in the top of the device:

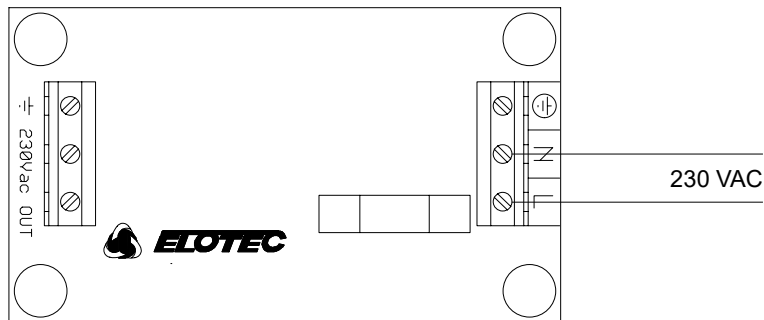

Connect the 10,8 V lithium battery to the plug and fasten it in the opening in the middle of the CPU board:

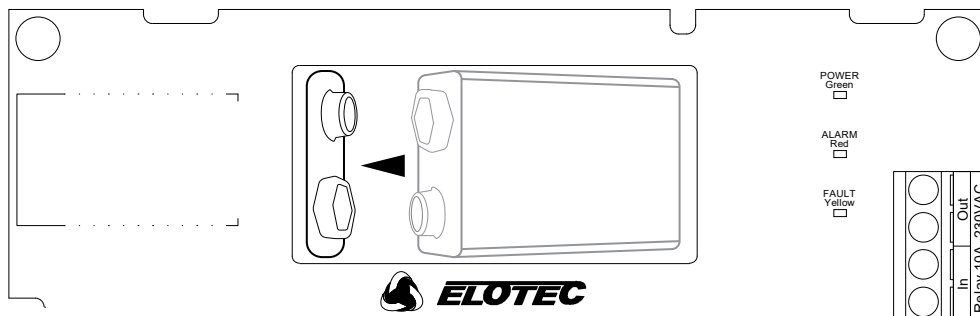

According to EN 60065 (European norms for low-voltage equipment), equipment with a permanent connection to mains shall have a two-pole cut-out switch with a distance between its contacts of at least 3 mm. The requirement is met by installing EloClean and ASPECT on a circuit with an automatic fuse.

3.3. PROGRAMMING THE INTERVAL FOR AUTOMATIC CLEANING

To set a cleaning interval, EloClean must be put into programming mode. The interval may be set from 1–7 days.

1. Hold button for five seconds – until the blue LED marked “Prog” lights up. When the LED turns on, programming must begin within 10 seconds, or EloClean will automatically return to normal operation.
2. Press button the number of days (1–7) you wish as the interval for automatic cleaning. There can be no more than 2 seconds between each press. If more than 2 seconds pass between presses, programming ends automatically.

When programming ends, the blue LED will blink the number of days selected, accompanied by the same number of beeps. The LED will then turn off to indicate normal operation.

4. TECHNICAL SPECIFICATION

4.1. GENERAL

4.1.1. Mechanical

- Dimensions (B x H x D): 272 x 578 x 143 mm
- Housing: Extruded aluminium profile with PC/ABS top and bottom
- Protection rating: IP44

4.1.2. Electrical

- Supply voltage: 230 VAC, 50 Hz

4.1.3. Environmental

- Operating temperature: -40 to +60 °C
- Relative humidity: Max. 98%

4.2. USER INTERFACE

4.2.1. Indications

- Status, operation: 1 x green LED
- Status, programming: 1 x blue LED
- Fault: 1 x yellow LED

Red LED is not in use for this product.

4.2.2. Buttons

- 1 pc. internal, for manual start of cleaning procedure

4.3. OUTPUTS

4.3.1. Relay outputs

- Fault output: Normally Closed, max. 2 A @ 30 VDC

Other outputs on the CPU board are not in use for this product.

4.3.2. Inputs

- Aux input AUX1: Input for remote control of cleaning procedure

Other inputs on the CPU board are not in use for this product.

APPENDIX Z – CE MARKING AND DECLARATIONS

Elotec AS , Søndre Industrivegen 3 N-7340 Oppdal, NORWAY 18
<i>Low Voltage Directive, 2014/35/EU</i> IEC 61010-1:2010/AMD:2016 Safety requirements
<i>EMC Directive, 2014/30/EU</i> EN 61326-1:2013 EMC requirements
<i>RoHS Directive, 2015/863</i>

Elotec AS hereby declares that the product **EloClean**, in accordance with the above directives and regulations, complies with the relevant requirements in the listed standards.

Jan Kleven, CEO

Warning / Liability

If the equipment is not used in accordance with the mounting/installation requirements, for other purposes than intended, connected to other equipment than prescribed in this manual, or connected to such equipment in any other way than prescribed, this could result in damage to the equipment or to other connected devices, as well as other damages such as overheating, fire, explosion, electromagnetic interference and so on.

In all above-mentioned cases, the manufacturer of the equipment cannot be held responsible for any damage and loss, including damages and losses caused to the property of a third part.

In the cases described above, the buyer's warranty is void

Elotec AS

Søndre Industrivegen 3
7340 Oppdal
NORWAY

Switchboard: +47 72 42 49 00
Support: +47 72 42 49 60

E-mail: info@elotec.no
Web: www.elotec.com