



**PIEZOCERAMIC DETECTOR FOR GLAZED SURFACES**



P/N SN-SPC-GL



**DESCRIPTION**

Piezoceramic detector with integrated electronics for glass breaking through detection. Fixed to glass with any inclination and orientation, it is equipped with anti-removal device, magnetic anti-masking function, digital sensitivity adjustment (four levels) to adapt its functioning to the different types of glass (including multilayer and shatterproof glass), settings for sensitivity adjustment and resistive balance of the output lines. A low power supply causes the alarm relay to be activated.



**PACKAGE CONTENTS**

SN-SPC-GL sensor, fixing base, biadhesive, datasheet.



**COVERAGE AREA**

The coverage area of the detector depends on the type of glass to be protected:

- Approximately 3m<sup>2</sup> on double-layer glass type 10/11 mm

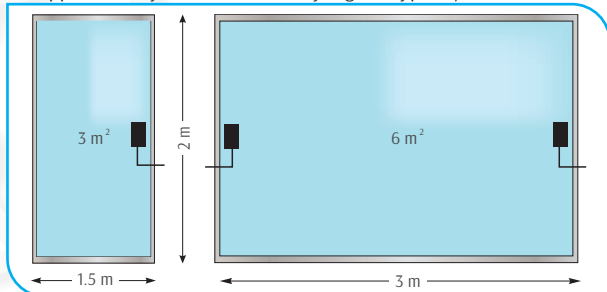

- Approximately 2m<sup>2</sup> on shatterproof glass up to 26 mm

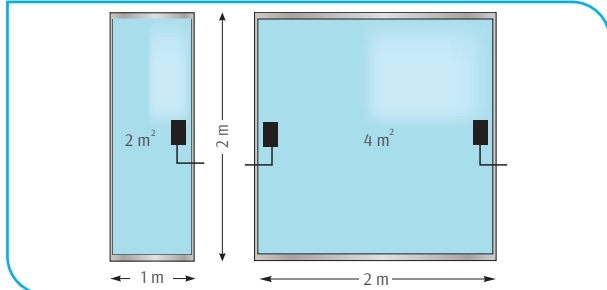

- The coverage area is considered with the detector in mid position respect to the longest side (A). In case of positioning in the corner area (B), check the detector coverage up to the opposite corner and, if needed, use a second detector.

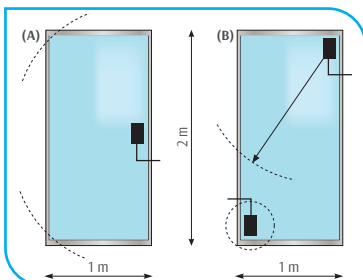

**COMPLIANCE**

- Directive 2014/30/EU
- EN 50130-4:2011
- EN 61000-6-3:2007+A1:2011



**TECHNICAL FEATURES**

- SECURITY GRADING:** designed in accordance with Grade 2 (EN 50131-2-7)
- ENVIRONMENTAL CLASS:** designed in accordance with Class II (EN 50131)
- DIMENSIONS:** 45 x 43 x 15 mm (L x H x W)
- GROSS WEIGHT:** 63 g
- NET WEIGHT:** n.a.
- IP RATING:** IP55
- COLOUR:** bianco
- POWER SUPPLY:** 12 V<sub>cc</sub> (±25%)
- CURRENT:** 3 mA (stand by) - 6 mA (max)
- OPERATING TEMPERATURE:** 0 °C ± +70 °C
- RELATIVE HUMIDITY:** <95% non condensing
- FUNCTIONS AND DEVICES:**
  - anti-removal tamper
  - magnetic anti-masking
- CONNECTIONS:** 6 conductors (Power supply, alarm signal line, tamper line)
- OUTPUTS:**
  - burglar alarm
  - breaking through
  - tamper
- AVERAGE COVERAGE AREA:**
  - 3 m<sup>2</sup> (double layer glass, up to 11 mm thick)
  - 2 m<sup>2</sup> (reinforced glass, up to 26 mm thick)

**DIMENSIONAL SCHEME**

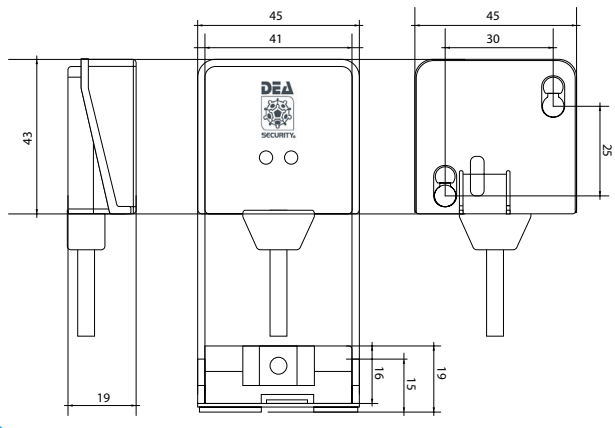

**APPLICATIVE EXAMPLE**





## INSTALLATION

If you lower the tab L using a screwdriver in the slot F, the detector slides towards the output side of the cable.

### INSTALLATION SCHEME

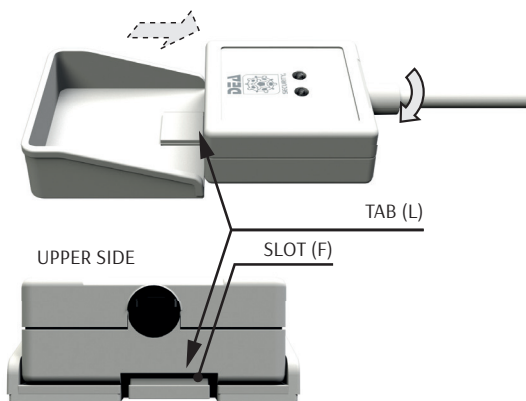

## CONNECTIONS

The detector is supplied with approx. 1,5 m of 6-wire connection cable: 2 wires (red and black) for power supply (12Vdc), 4 wires (white) distinguishable by different cutting lengths: tamper line (shorter pair) and alarm line.

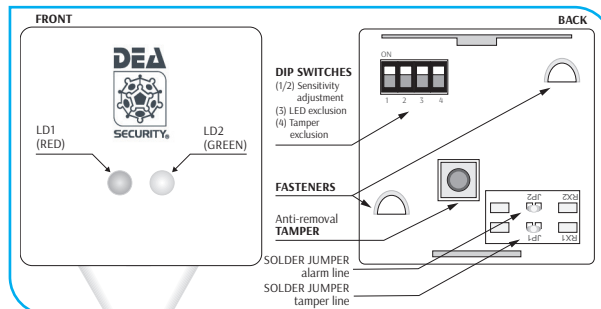
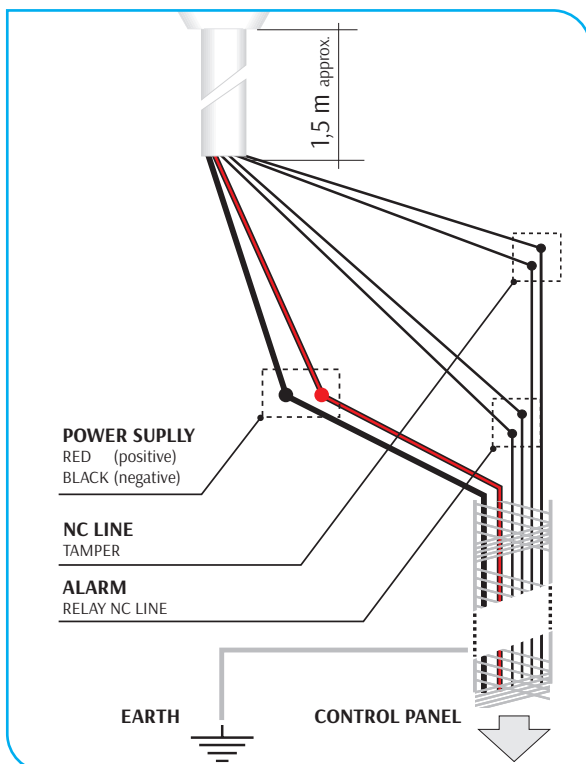

## DETECTOR ALARM MEMORY RESET

Following a strong impact which could compromise the integrity of the glass, the detector activates the alarm status. The signalling occurs through the impulsive opening of the alarm line (NC by relay) and the lighting up of LD1 LED (red). The alarm output is reset automatically. The LD2 LED (green) also lights up impulsively. The opening of the relay and the lighting of the LD1 LED have a duration longer than 1 second, at the end of which the detector returns to the normal surveillance status. The alarm memory must therefore be managed by the alarm control panel.



## CALIBRATION

The detector has, in its lower part, 4 DIP SWITCHES with 4 positions. From the left DIP SWITCHES 1 and 2 allow you to calibrate the sensitivity depending on the type of glass and the desired sensitivity level. The set calibration should be always tested.



- **HIGH sensitivity**  
eg.: thick multi-layer glass (30 mm)
- **MEDIUM-HIGH sensitivity**  
eg.: for thick double-layer glass
- **LOW sensitivity**  
eg.: for single-layer glass

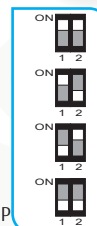

DIP SWITCH 3 allows you to disable the LEDs, whilst DIP SWITCH 4 disables the tamper.

- **Calibration test:** the correct calibration (sensitivity level) can be verified by simulating a strong impact on the glass, with the lighting up of LD2 LED (green).
- **Line balance:** the tamper and the alarm lines can be balanced by welding the related resistor in the specific opening (rear side of the detector).
  - ▶ Tamper line: remove JP1 solder jumper with the tip of the soldering iron and insert the resistor between RX1 outer pads.
  - ▶ Alarm line: remove JP2 solder jumper with the tip of the soldering iron and insert the resistor between the outer pads of RX2.

**N.B.** USE A SHIELDED CABLE TO CONNECT THE SENSOR TO THE CONTROL PANEL. CONNECT THE CABLE SHIELD TO THE SYSTEM EARTH. ALL OF THE JUNCTIONS MUST BE TIN SOLDERED.

## DEA Security S.r.l.

Via Bolano, snc - 19037 Santo Stefano di Magra (SP) - tel. +39 0187 699233 - fax +39 0187 697615  
VAT No.: IT00291080455  
www.deasecurity.com - dea@deasecurity.com

© 2020 DEA Security S.r.l. - Edizione August 2020 - v. 2.0.0.  
DEA Security S.r.l. reserve the right to vary at any moment and without notice the information and the technical features herein.

