

DUOX^{plus}

FERMAX

DUOX PLUS SYSTEM

TECHNICAL BOOK
SECTION I

en.

DUOX PLUS TECHNICAL BOOK

The DUOX PLUS technical book consists of two sections:



- Section I: Description of the DUOX PLUS system (Cod. 970122Ib-1)
- Section II: DUOX PLUS installation diagrams (Cod. 970122Ib-2)









DUOX PLUS technical book - Section I

Code 970122Ib-1 V06_20

This technical document has been edited by FERMAX ELECTRÓNICA S.A.U. for informational purposes, and the company reserves the right to modify any of the technical specifications of the products referred to herein at any time without prior notice. These changes shall be reflected in later editions of the same document.

INDEX

	1. INTRODUCTION	6
	1.1 DUOX PLUS: EASE OF INSTALLATION	6
	1.2 COMPONENTS OF A DUOX PLUS SYSTEM	7
	1.2.1 OUTDOOR PANEL	7
	1.2.2 AUDIO GUARD UNIT	7
	1.2.3 DUOX PLUS POWER SUPPLY	8
	1.2.4 LINE ADAPTER	8
	1.2.5 REGENERATORS	8
	1.2.6 APARTMENT TERMINALS: MONITORS AND TELEPHONES	8
	1.3 PRINCIPAL TECHNICAL SPECIFICATIONS OF THE DUOX PLUS SYSTEM	9
	1.4 OPERATING PRINCIPLES OF THE DUOX PLUS SYSTEM	10
	1.5 RECEIVING CALLS	12
	1.5.1 MAKING CALLS BASED ON THE CONFIGURATION OF THE OUTDOOR PANEL	12
	1.5.2 EXAMPLES OF THE CONFIGUR. OF OUTDOOR PANELS AND APARTMENT TERM.	13
	2. DUOX OUTDOOR PANELS	20
	2.1 DUOX PLUS AMPLIFIERS	20
	2.1.1 VIDEO AMPLIFI. FOR CITYLINE AND MARINE OUTDOOR PANELS WITH PUSHB.	21
	a) Settings	21
	b) Configuration	22
	c) Pre-wiring	24
	2.1.2 VIDEO AMPLIFIER FOR SKYLINE, DIRECT AND DIGITAL OUTDOOR PANELS	29
	a) Settings	29
	b) Configuration	31
	c) Pre-wiring	34
	2.1.3 AUDIO AMPLIF. FOR CITYLINE AND MARINE OUTDOOR PANELS WITH PUSHB.	37
	a) Settings	37
	b) Configuration	38
	c) Pre-wiring	40
	2.1.4 AUDIO AMPLIFIER FOR SKYLINE, DIRECT AND DIGITAL OUTDOOR PANELS	45
	a) Settings	45
	b) Configuration	47
	c) Pre-wiring	50
	2.2 ADVANCED PROGRAMMING	53
	2.2.1 MAPPING IN PUSHBUTTON PANELS	53
	2.2.2 MAPPING IN DIGITAL PANELS	58
	2.2.3 ADVANCED PROGRAMMING OPTIONS IN DIRECT PANELS	60
	3. DUOX AUDIO GUARD UNIT	61
	1. Control buttons	62
	2. Operation	62
	3. Connection terminals, technical specifications and default values	64

	4. DUOX PLUS POWER SUPPLY	65
	5. DUOX PLUS LINE ADAPTER	67
	5.1 DEVICES WHICH INCLUDE A LINE ADAPTER	67
	5.2. WHERE TO INSTALL A LINE ADAPTER AND HOW TO CONFIGURE IT	69
	6. DUOX PLUS REGENERATOR	73
	6.1 DUOX PLUS DUAL REGENERATOR (REF. 3268)	74
	6.2 DUOX PLUS 2S REGENERATOR (REF. 3269)	78
	6.3 COMPARISON OF REGENERATORS	81
	7. APARTMENT TERMINALS	82
	7.1 VEO XS MONITOR AND VEO XS WIFI	83
	Control buttons/LEDs	83
	Connections	84
	Monitor programming	84
	User settings	85
	Technical specifications	86
	FUNCTIONING. PAIRING. Call forwarding.	87
	7.2 VEO MONITOR AND VEO WIFI	89
	Control buttons/LED	89
	Connections	89
	Monitor programming	90
	User settings	91
	Technical specifications	92
	FUNCTIONING. PAIRING. Call forwarding.	93
	7.3 VEO TELEPHONE	95
	Control buttons	95
	Connections	95
	Telephone programming	96
	User settings	96
	Technical specifications	97
	7.4 LOFT EXTRA TELEPHONE	97
	Control buttons/LED	97
	Connections	97
	Telephone programming	98
	User settings	99
	Technical specifications	99
	7.5 iLOFT TELEPHONE	100
	Control buttons/LEDs	100
	Connections	100
	Telephone programming	101
	User settings	102
	Technical specifications	103

 7.6 LOFT BASIC PLUS TELEPHONE	103
Control buttons	103
Connections	103
Telephone programming	104
Technical specifications	104



8. DUOX PLUS ACCESSORIES **105**

8.1 DUOX PLUS RELAY	105
8.2 DUOX PLUS LIFT CONTROL UNIT	106
8.3 DUOX PLUS CAMERA INTERFACE	108



9. DUOX PLUS INSTALLATIONS **109**

9.1 PRIOR CONSIDERATIONS REGARDING WIRING AND DUOX PLUS CONSUMPTION	109
9.2 BASIC VIDEO INSTALLATIONS (Monitors) AND MIXED INSTALLATIONS (Monitors + Telephones)	110
9.2.1 EXAMPLE OF A DUOX PLUS BASIC INSTALLATION. 1 RISER	110
9.2.2 EXAMPLE OF A DUOX PLUS BASIC INSTALLATION. 2 RISERS	111
9.2.3 EXAMPLE OF A DUOX PLUS BASIC INSTALLATION. 3 RISERS	111
9.2.4 EXAMPLE OF A DUOX PLUS BASIC INSTALLATION. 4 RISERS	112
9.3 BASIC AUDIO INSTALLATION (Telephones)	112
9.4 EXTENDED INSTALLATION	113

1. INTRODUCTION

DUOX PLUS is the first completely digital video door communication system to be based on 2 non-polarised wires.

These specifications make it an extremely versatile and scalable system which is highly recommended in both new-build and replacement facilities. In the latter case, the DUOX system has a wide range of scope for application as a result of its flexibility, meaning that it can be installed using a wide range of wiring arrangements.

Its flexibility also extends to the level of choice afforded to users. Having originally decided to install a telephone in their apartment, users may change this for a monitor whenever they wish to.

DUOX makes it possible to have:

- Two communication channel in the same block.
- Up to 10 outdoor panels and 10 guard units in the General Entrance.
- 99 blocks with up to 10 outdoor panels and 10 guard units in each of these.
- 99 sub-blocks with up to 10 outdoor panels in each of these.
- Up to 999,999 apartment addresses.

This is all possible with a limited number of intermediary elements.

1.1 DUOX PLUS: EASE OF INSTALLATION

With DUOX, it is possible to save time in installation, as a result of:

A) The limited number of elements required for installation:

- No distributors
- No switchers
- No decoders

B) Intuitive programming:

DUOX PLUS is extremely easy to programme. No additional elements are required for the set-up process:

- DUOX PLUS monitors can be programmed within seconds, directly from the terminal menu, which makes it possible for one single person to programme the installation.
- The panels include a remarkable voice synthesis system which guides the person in charge of the installation through the programming process.

DUOX PLUS Video Door System Installation

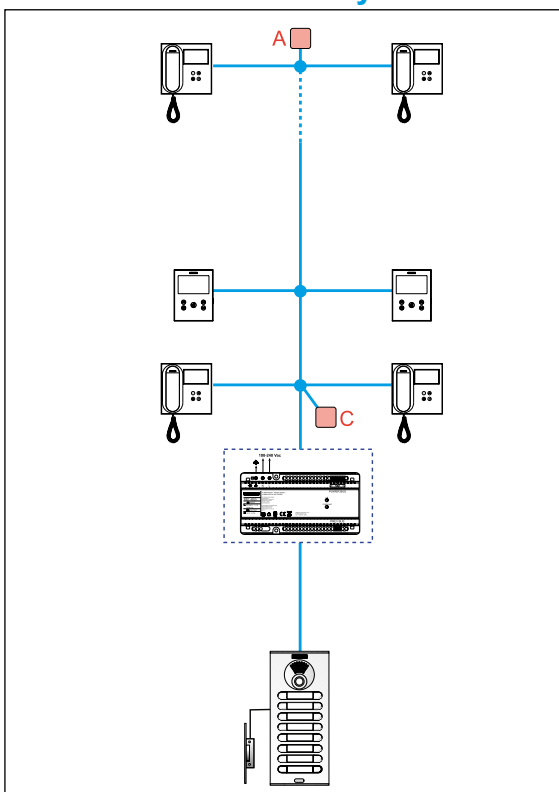

DUOX PLUS Door Installation

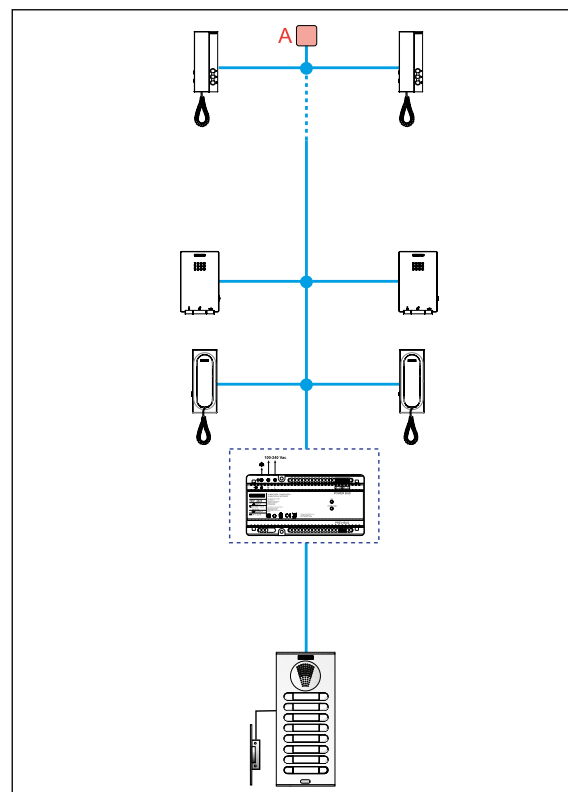

1.2 COMPONENTS OF A DUOX PLUS SYSTEM

The main components of the DUOX system are those which are present throughout all of the installations, regardless of the size of these.

1.2.1 OUTDOOR PANEL

These are available in all of the FERMAX styles: Cityline, Skyline and Marine.

Depending on their function (the way in which they make the call) and the intrinsic specifications of the model, the outdoor panels may be: Pushbutton, Direct or Digital.

They are available with video and audio. The DUOX PLUS video panels have a digital microphone integrated into the amplifier module.

For more information, *see subsection 2. DUOX PLUS outdoor panels.*

Outdoor panels with different aesthetics:

VIDEO

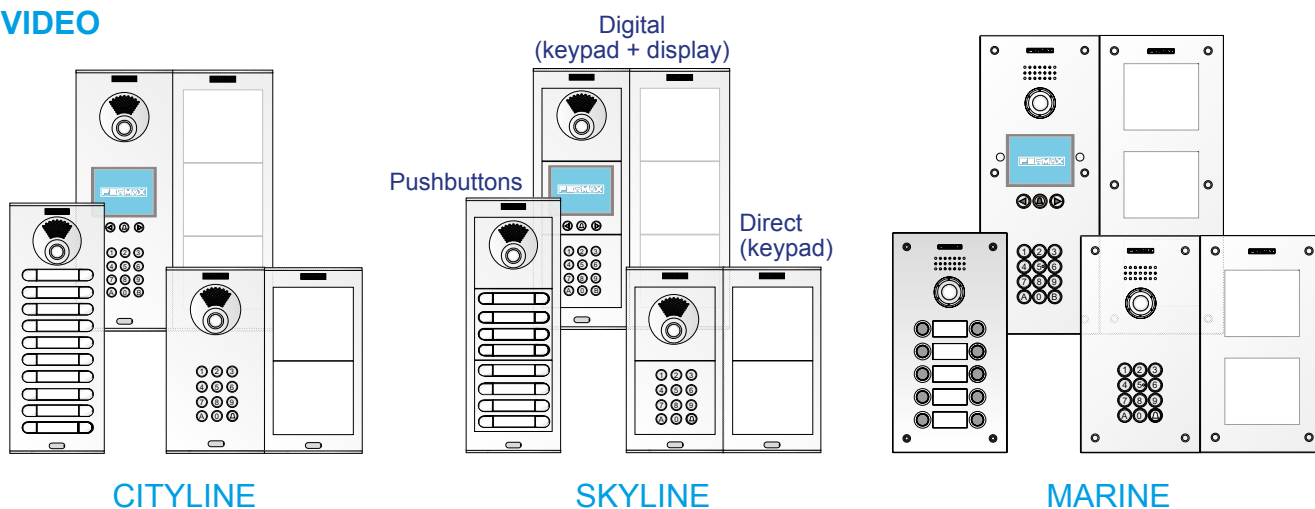

AUDIO

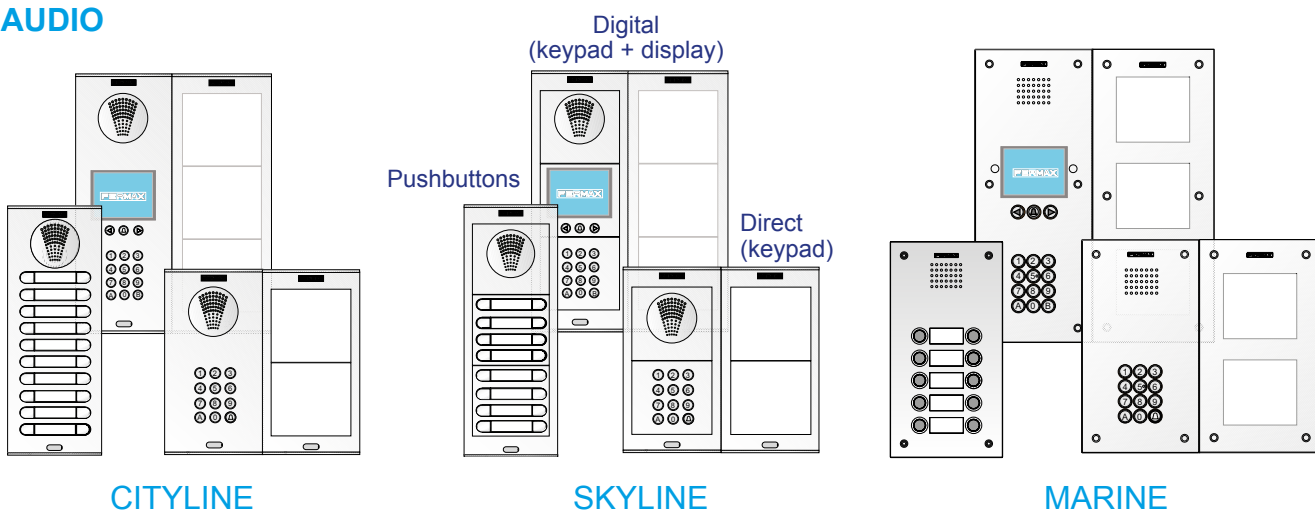

1.2.2 AUDIO GUARD UNIT

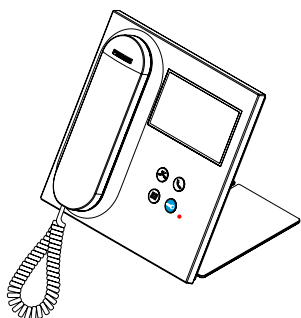

The DUOX PLUS system can be complemented with one or more Guard Units (in the general entrance and/or in internal blocks) which can be wall-mounted or desk-mounted.

The central unit of the guard unit acts as a “filter” between residents of a building and visitors.

For more information, *see subsection 3. DUOX PLUS Audio Guard Unit.*

Note: It is also possible to refrain from employing the outdoor panel as long as there is at least 1 Guard Unit.

1.2.3 DUOX PLUS POWER SUPPLY

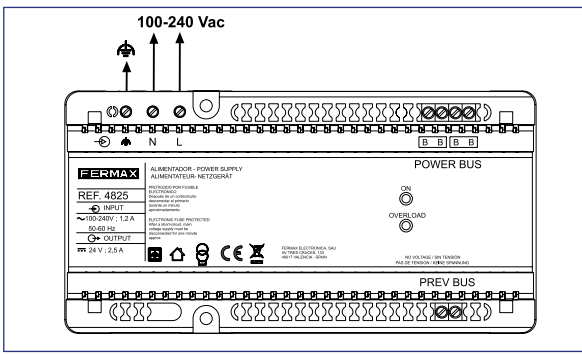

The DUOX PLUS system uses a power supply with built-in filter, ref. 4825, which allows power and data to go through the same cable. Under certain circumstances, such as space limitations in registers, it may be necessary to separate the power supply and the filter in two devices, so the 24V Power Supply ref.4840 and the DUOX PLUS 24v filter ref. 3289 can be used together.

For more information, *see section 4 DUOX PLUS Power supply.*

1.2.4 LINE ADAPTER

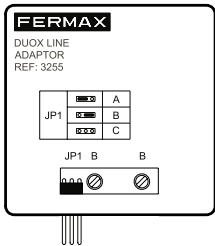

With the DUOX PLUS system it is necessary to adapt the transmission line. Line adapter ref. 3255 can be used for this purpose. This adapter balances impedances in the transmission line.

There are also other devices that include a line adapter in their structure. For more information, *see subsection 5. DUOX PLUS line adapter.*

1.2.5 REGENERATORS

The main function and purpose of a regenerator is to increase distances, risers and terminals in an installation.

There are 2 types of regenerators. Each one of these has its own specific technical characteristics and guidelines for usage.

For more information, *see subsection 6. DUOX PLUS Regenerator.*

Regenerator models:

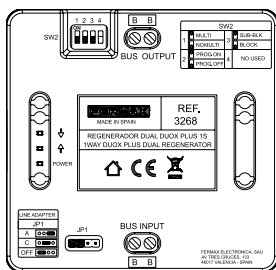



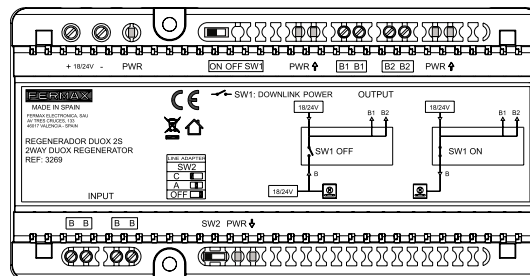



DUOX PLUS Regenerator
1 Output (ref. 3268)

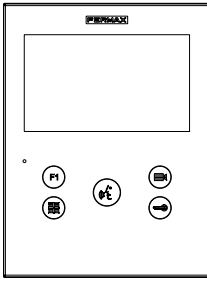
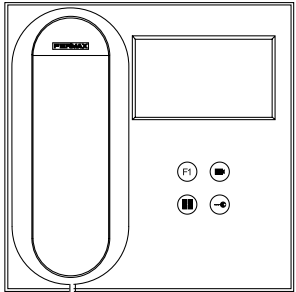
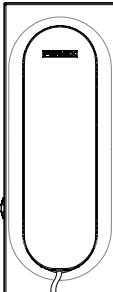
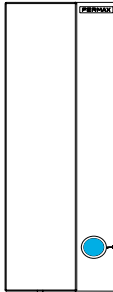
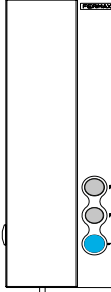
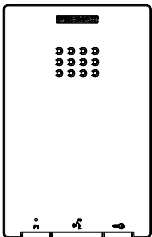

DUOX PLUS Regenerator 2 Outputs
(ref. 3269)

1.2.6 APARTMENT TERMINALS: MONITORS AND TELEPHONES

For more information, *see subsection 7. Apartment Terminals.*

MONITORS		TELEPHONES			
					
VEO XS	VEO	VEO	LOFT BASIC PLUS	LOFT EXTRA	iLOFT
					

1.3 PRINCIPAL TECHNICAL SPECIFICATIONS OF THE DUOX PLUS SYSTEM

- A simplified installation system in two non-polar wires, which require neither floor distributors nor outdoor panel switchers. **This leads to a considerable reduction in installation time.**
- The signal transmission (audio, video and data) is completely digital, allowing it to maximise its capacity and robustness to noise and interference. **This ensures consistent audio and video quality throughout the installation besides two simultaneous video communication channels over a single pair of wires.**
- Voice-guided programming in outdoor panels and via a graphic menu on monitors.
- Substitution of a telephone with a monitor at the apartment, without requiring additional accessories.

Wiring	Flexible topology with 2 non-polarised wires.
Supported cables	- Parallel (2 x 1.0 mm ²). Recommended cable Ref. 5925. - Twisted pair - UTP - 2 doorbell wires - 4+N cable
Distance between edges of the installation	Up to 3,000 metres with regeneration.
Distance between regenerators in a terminal-free bus	Up to 500 metres.
Connection of terminals	Connections are made using a connection strip, without the need to install distributors.
Conversation mode	Full-duplex in models with headsets. Natural conversation in hands-free models.
Power supply voltage	24Vdc
Maximum conversation time	90 seconds.
Maximum number of addressable apartments	999,999 (6-digit addressing).
Structure of the installation	General Entrance (up to 10 outdoor panels and 10 guard units). 99 blocks (up to 10 outdoor panels and 10 guard units in each block). 99 sub-blocks (up to 10 outdoor panels in each sub-block).
Maximum number of terminals per apartment	3
Maximum number of guard units per installation	10 in the General Entrance / 10 per Block.

- Line adapters are required to balance impedances.
- Privacy (complete confidentiality) in conversations. It is not possible to listen to a third-party conversation (even between terminals installed in the same apartment).

If a conversation is underway, the system will not function for the rest of the terminals (during a pre-established time period).

- Auto-start.

The apartment terminals can be auto-started with the outdoor panel as long as the system is not busy. The monitors have a specific button for this function, whereas in the case of telephones, auto-start takes place when the headset is picked up or when audio communication is established (headset-free model: hands-free).

Notes:

- The availability of this function depends on the type and configuration of the installation. See subsection 7. Apartment terminals.

- If a call is received from another panel, when the conversation has been completed, for 15 seconds, **auto switch-on** will happen with that panel.

- Programming of the Lock Release Time and the Exit Pushbutton Time (egress).

Both times can be quickly and easily programmed for the lock release.

- Auto hang-up.

DUOX PLUS monitors hang up automatically 5s after the door is opened. It is possible to configure the Auto hang-up on the DUOX PLUS amplifier so that this setting is applied to all the terminals in the installation, whether they are phones, guard units or monitors, so that the channel is released 5s after the door is opened.

- Easy extension.

It is possible to quickly and easily create enclosures from various exterior access points to various internal blocks.

DUOX Video Door System Installation

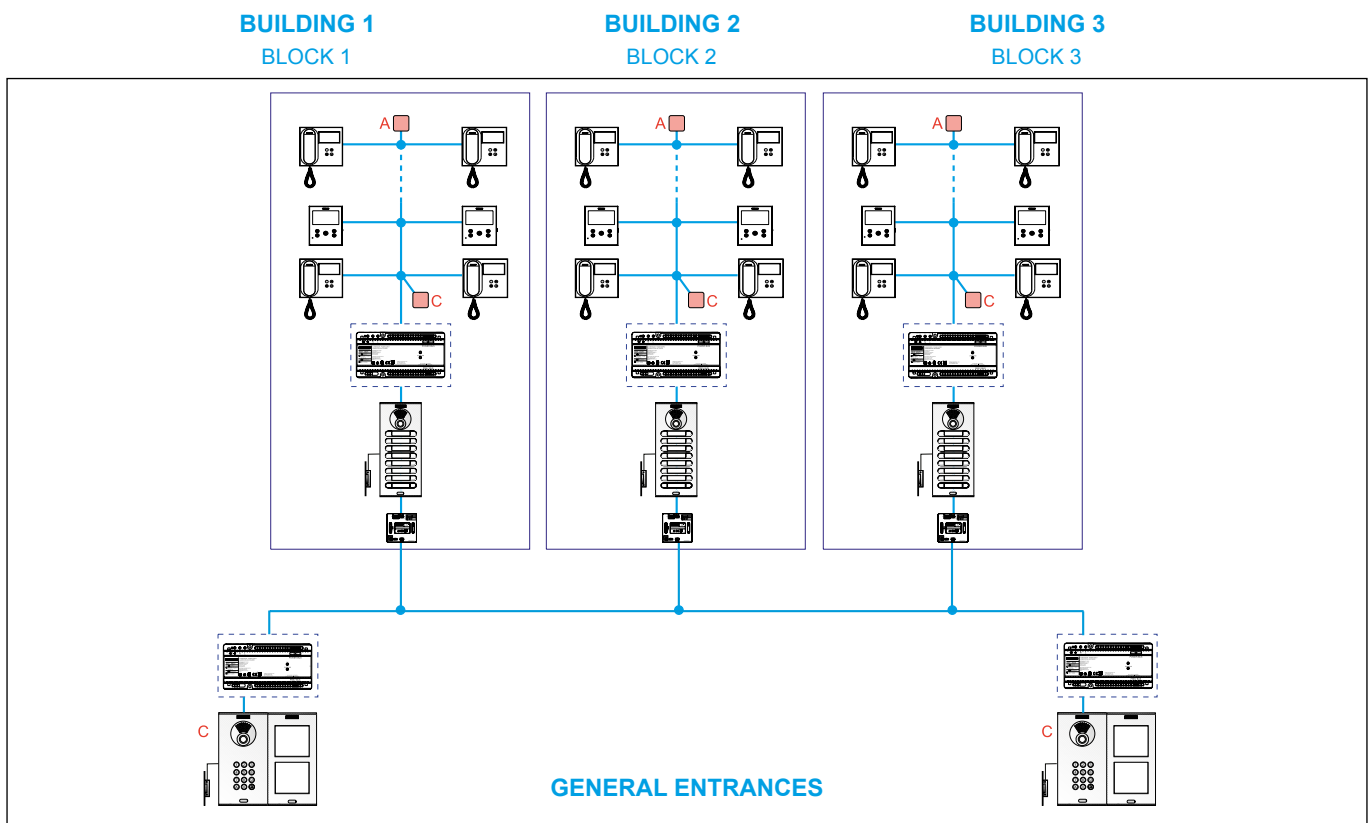

1.4 OPERATING PRINCIPLES OF THE DUOX PLUS SYSTEM

The call is made from the outdoor panel, sent through the bus and received at the specified terminal. When the terminal answers the call, a communication channel is established between the outdoor panel and the apartment terminal.

Each apartment terminal (telephone/monitor) is programmed with an address that identifies its location in the installation and distinguishes it from the rest of the terminals. Each outdoor panel is also configured in such a way that it can be distinguished from the rest of the panels in the installation.

- **Call:**

When a call is made from the outdoor panel to an apartment, the amplifier that is incorporated within the panel generates the corresponding "call code/call direction" and sends it through the bus.

The type of outdoor panel will determine how the call is made and how the call code is generated:

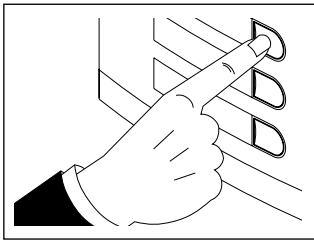
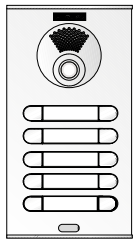

Pushbutton outdoor panels: In the pushbutton panels, each pushbutton corresponds to a specific “call code/call direction”. This means that the call to the apartment is placed by pressing the corresponding call button.

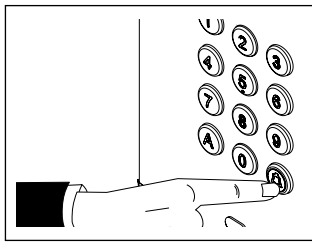
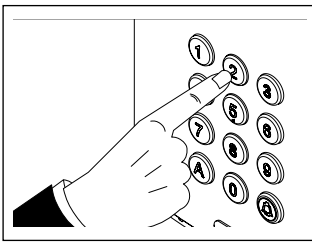
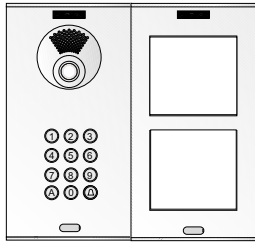

Keypad panels (Direct): The call to the apartment is placed by entering the “call code/call direction” that has been assigned to each apartment terminal, using a numerical keypad which also has an access control function.

Call: apartment number + 

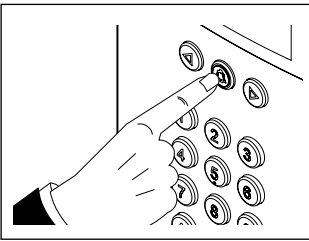
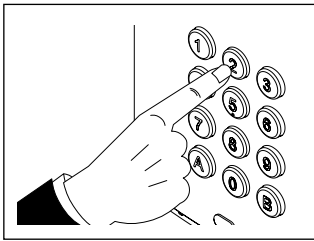

Outdoor panels with keypad and electronic directory (Digital with extra display): The call to the apartment is placed by entering the “call code/call direction” that has been assigned to each apartment terminal, using a numerical keypad which also has an access control function.

Call: apartment number + 

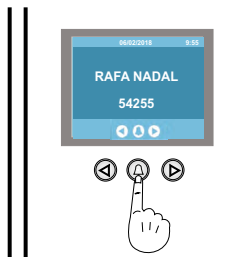
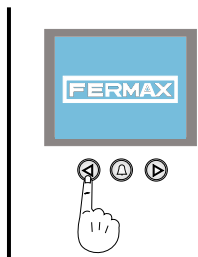

Digital Panels with extra display include an electronic directory which enables users to search for names using the incorporated display and to call the apartment of the name that has been searched for by pressing the “bell” key.

Note: In the digital panels and pushbutton panels, the “call code/call direction” can be reprogrammed (mapped call). Mapped call: Mapping is an advanced programming option which enables the modification of the call code that has been inherently assigned by the system for another different call code in order to cover all of the coding requirements. See subsection 2.2 Advanced Programming.

- Call reception.

The call code sent through the bus is received by all of the terminals in the installation but it is only recognised by the apartment terminal (or terminals) that have been programmed with this same code, generating the call ring tone in the apartment and the activation of the video function (in terminals with video).

Note: The exception is when multi-channel regenerators are used in blocks and these will only allow the calls corresponding to their block to pass. See sub-section 6.3 DUOX PLUS 1S DUAL regenerator (ref. 3268).

- Communication and door release.

When the apartment terminal receives the call (its address matches the call code generated by the amplifier), a direct connection is established between the terminal that is being called and the outdoor panel/guard unit from which the call has been made.

Upon pick-up or the establishment of communication in the terminal (depending on the model), audio/video communication will be established between the terminal and the outdoor panel/guard unit.

This communication is limited to a maximum time of 90 seconds (once this time has elapsed, communication is cut) and a minimum time of 15 seconds (during which time no call requests from the outdoor panel or the auto-switch on from other terminals are attended).

It is also possible to establish communication with the outdoor panel without a previous call using the auto switch-on function which is available in audio and video terminals, (*see section 7. Apartment Terminals*). During the communication interval, it is possible to release the door using the pushbutton that has been enabled for this purpose in the apartment terminal. On terminals with Auto Hang-up or when this function is set on the amplifier, the channel returns in stand by 5 seconds after door opening.

- The end of the communication can happen for one of these three reasons:
 - Hang-up/Closing communication channel (depending on terminal model).
 - After the maximum communication time of 90 seconds
 - After 5 seconds from opening on terminals with Auto Hang-up on all terminals when this function is set on the amplifier.
- Activation commands.

The DUOX PLUS system incorporates pushbuttons F1 and F2 (depending on the models) in its apartment terminals. These enable the activation of external devices such as the DUOX relay for the management of additional features such as courtesy lights, secondary foods, garages and so on. (*See sub-section 8.1 DUOX PLUS Relay*).

1.5 CALL CODIFICATION

The DUOX system uses 6-digit apartment terminal addresses [000001 - 999999]. This provides a great deal of flexibility in terms of being able to number the terminals in accordance with the conventions of each country.

The digits of the call code are arranged as follows:

BBSSNN:

- **BB** indicates the **block number (00..99)**. Apartments per block: Maximum 9999.
 - **SS** indicates the **sub-block number (00..99)**. Apartments per sub-block: Maximum 99.
- The term sub-block refers to a part of a block which may be worth sub-dividing for organisational purposes. For example, a sub-block may consist of a building, a floor of a building or an area of a condominium made up of villas, among other things.
- **NN** indicates **the apartment number in the sub-block (01..99)**. This can range from 01 to 99.

It is not always necessary to adhere to this address structure. It can be adapted to suit the installation, depending on the requirements in each case.

The **outdoor panels** can be configured in the following form:

- General Entrance [G]. Enables a call range of 000001 to 999999.
- Block entrance [B]. Enables a call range of 0001 to 9999.
- Sub-block entrance [S]. Enables a call range of 01 to 99.

Each panel, regardless of whether it is configured as a block, sub-block or general entrance, is assigned a panel number, ranging from 0 to 9. All panels are configured by factory default with the value 0 and as block panels.

For further details *see sub-section 1.5.2 Examples of the configuration of outdoor panels and apartment terminals*.

1.5.1 PLACING A CALL BASED ON THE CONFIGURATION OF THE OUTDOOR PANEL

The type of outdoor panel will determine how the call is made and how the call code is generated. For DUOX, the range is [000001-999999]. It is important to remember that depending on the type of outdoor panel, it may not be necessary to enter all of the digits when placing the call:

- General Entrance: 6 digits are used to place calls.
This may be different when using mapped calls, if there are zeros on the left hand side, or when selecting 4-digit dialling (Direct panels).

On an outdoor panel that is configured as a General Entrance, the range of accessible terminals will be all those in the installation BBSSNN (000001 to 999999).

Example of a call: Making a call from an outdoor panel in the General Entrance to Apartment 2 in Block 4:

- the code to enter is: 4 00 02
- the call code generated by the outdoor panel: 04 00 02

Notes:

- If a shorter code is entered than expected, a '0' is added on the left hand side, so there is no need to enter Block 04, only Block 4
 - The amplifiers are configured by default as outdoor panel 0, block 00, sub-block 00.
- Block Entrance: The last 4 digits are used for placing calls. The amplifier auto-completes the first two digits with the number of the block that is being called.

• A panel that is configured as a Block will only allow calls to terminals within the configured Block (BB).
Example of a call: Placing a call from an outdoor panel configured as Block 25 to Apartment 2.

- the code to enter is: 2
- The call code generated by the outdoor panel: 25 00 02

Notes:

- Block Entrance: When calling, the amplifier auto-completes the first two digits with the block number that has been configured, by default it is 00.
- If a shorter code is entered than expected, a '0' is added on the left hand side, so there is no need to enter: Sub-block 00 Apartment 02 -> 00 02, only 2.

- Sub-block entrance: the last 2 digits are used to place calls. The amplifier auto-completes the first two digits with the number of the block and the following 2 digits with the number of the sub-block that is being called.

- It will only allow calls to be made to the terminals in the configured Block (BB) and Sub-Block (SS).
Example: Placing a call from an outdoor panel configured as Block 12 Sub-Block 03 to Apartment 6.

- the code to enter is: 6
- the call code generated by the outdoor panel: 12 03 06

Notes:

- Sub-Block Entrance: When calling, the amplifier auto-completes the first four digits with the block number and sub-block number that have been configured, by default both are 00.
- If a shorter code is entered than expected, a '0' is added on the left hand side, so there is no need to enter: Apartment 06, only Apartment 6.

1.5.2 EXAMPLES OF THE CONFIGURATION OF OUTDOOR PANELS AND APARTMENT TERMINALS

At the back of the amplifier of the outdoor panel there is a **Label** which can be used to list programming information.

It is highly advisable to fill in the fields of the label which correspond to the programming made, in case it is necessary to extend the installation at a later date or in case the device fails and it is necessary to substitute it with a new one.

TYPE	N°
<input type="checkbox"/> EG	
<input type="checkbox"/> BK	
<input type="checkbox"/> SB	BK
N°PL	

The next pages will outline the following examples:

- 1) General Entrance with 2 Direct Outdoor Panels to 3 Internal Blocks with 1 Pushbutton Panel and 18 Apartments in each one of these.. 6 digits are used to place calls from the general entrance.
- 2) General Entrance with 2 Digital Outdoor Panels with Extra Display to 3 Internal Blocks with 1 Direct Outdoor Panel and 18 Apartments in each one of these. 3 digits are used when placing the call because mapping is made from the digital outdoor panels of the general entrance.
- 3) General Entrance with 2 Digital Outdoor Panels with Extra Display to 2 Internal Blocks with 1 Direct Outdoor Panel and 18 Apartments in each one of these. 6 digits are used to place calls from the general entrance.
- 4) General Entrance with 2 Direct Outdoor Panels to 6 Villas (Internal Blocks of 1 Apartment), with 1 single-line Pushbutton Panel in each one of these. 6 digits are used to place calls from the general entrance.
- 5) General Entrance with 2 Direct Panels to 2 Internal Blocks. On each floor of each internal block, 1 single-line outdoor panel per apartment configured as a Sub-Block. 6 digits are used to place calls from the general entrance. The number of the Sub-Block is the same throughout the internal block and it is necessary to map the pushbuttons of the single-line panels.
- 6) General Entrance with 2 Direct Panels to 2 Internal Blocks. On each floor of each internal block, 1 single-line outdoor panel per apartment configured as a Sub-Block. 6 digits are used to place calls from the general entrance. The Sub-Block number is different in the internal block and it is not necessary to map the pushbuttons of the single-line panels (Apartment 1).

Example 1

INTERNAL BLOCKS(using a 5-digit call from the EG)

There can be up to **99 Blocks**.

Each Block may have **9999 Apartments**, (in pushbutton panels it is possible to programme the pushbuttons up to address 99).

DIALLING from the pushbutton panel of the BLOCK

Calls from the Block are placed using the corresponding pushbutton (programmed as 1, 2, 3...18).

Auto switch-on with Outdoor Panel 0 or 1 of the Block in question and also with Outdoor Panel 0 of the General Entrance. (Selected from the monitor).

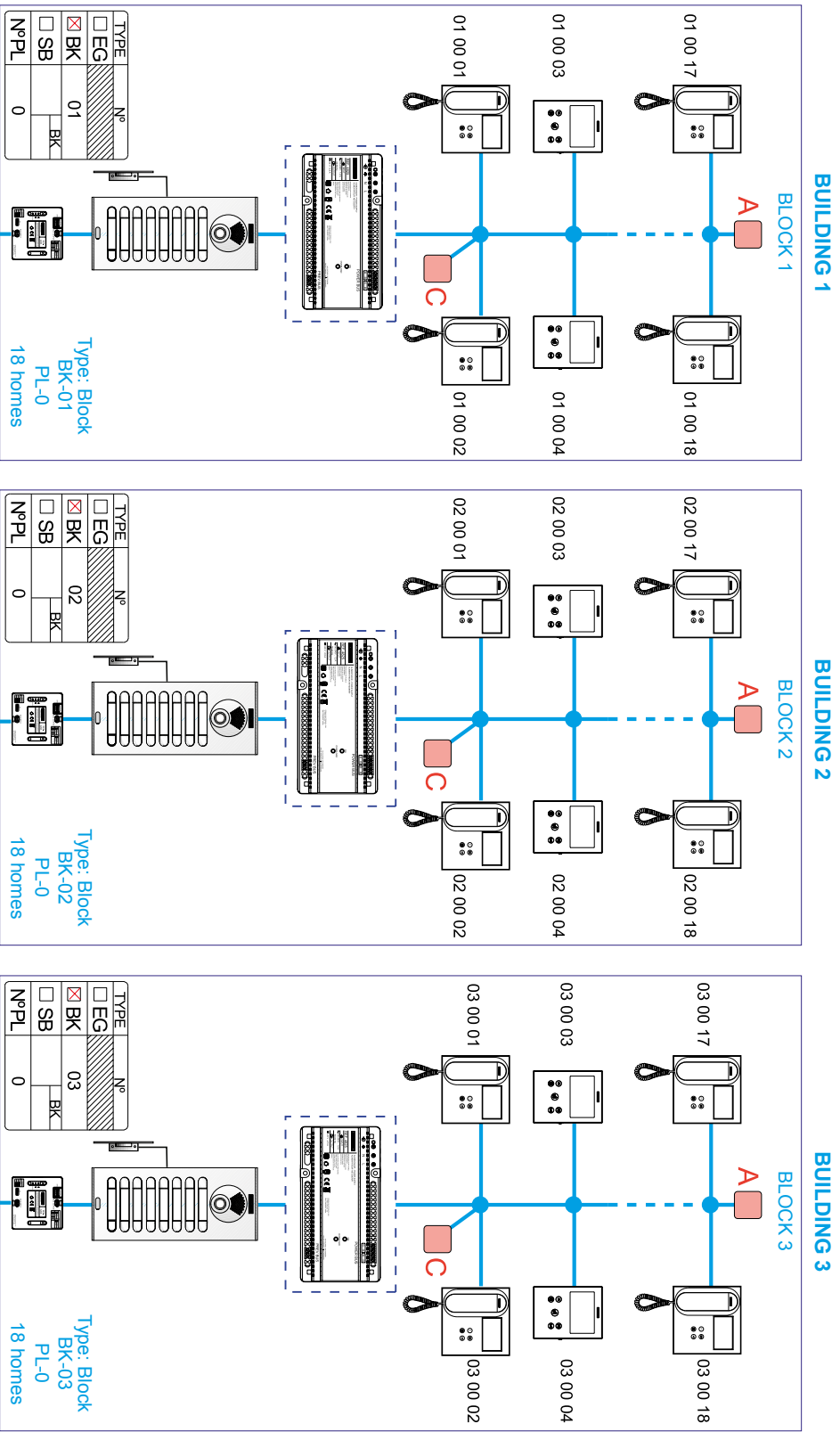

GENERAL ENTRANCE:

5-DIGIT DIALLING / 6 digits in the event of there being a Block '10, 11, 12...99' (100001 - 110001 - 120001 ... 990001)

The call is made from the direct outdoor panel of the EG by pressing:

- Block 01: 10001 ... 10018.
- Block 02: 20001 ... 20018.
- Block 03: 30001 ... 30018.

GENERAL ENTRANCES

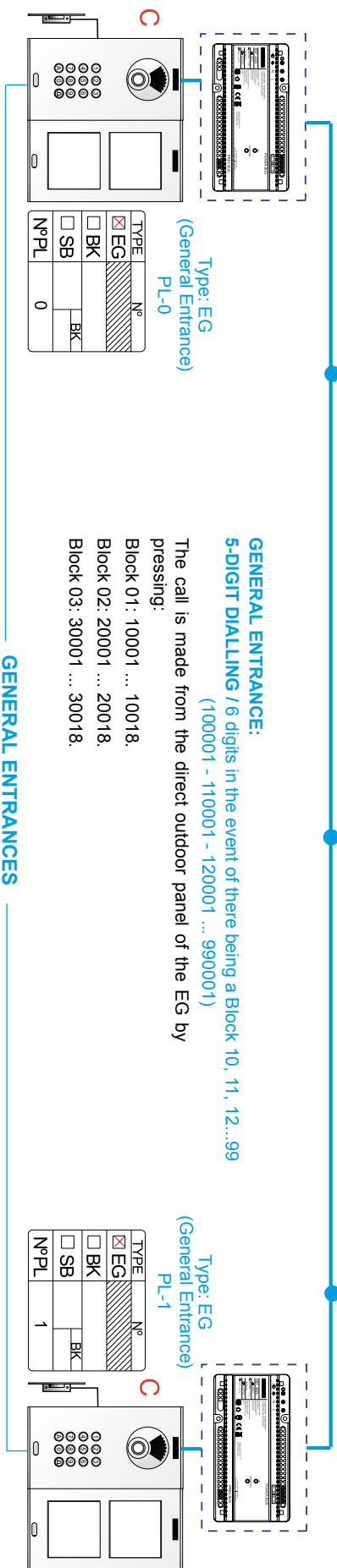

Example 2

INTERNAL BLOCKS (placing a 3-digit call from the EG after having mapped the digital outdoor panels with extra display: 101 - 201 - 301)

There can be up to **99 Blocks**.
Each block may have up to **99 Apartments**.

DIALLING from the Direct Outdoor Panel of the Block: 1, 2, 3...18
The call from the Block is placed by dialling the Apartment number (1, 2, 3...18).

Auto switch-on with Outdoor Panel 0 or 1 of the Block in question and also with Outdoor Panel 0 of the General Entrance.
(Selected from the monitor).

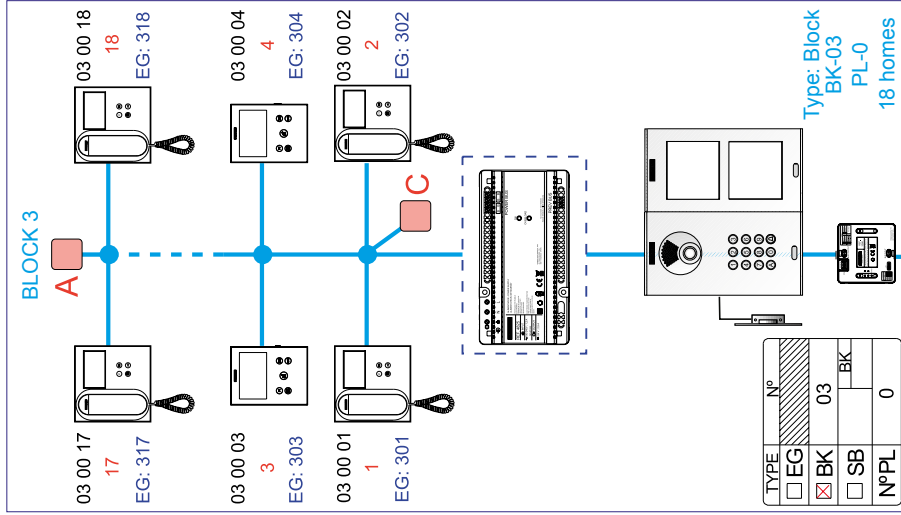
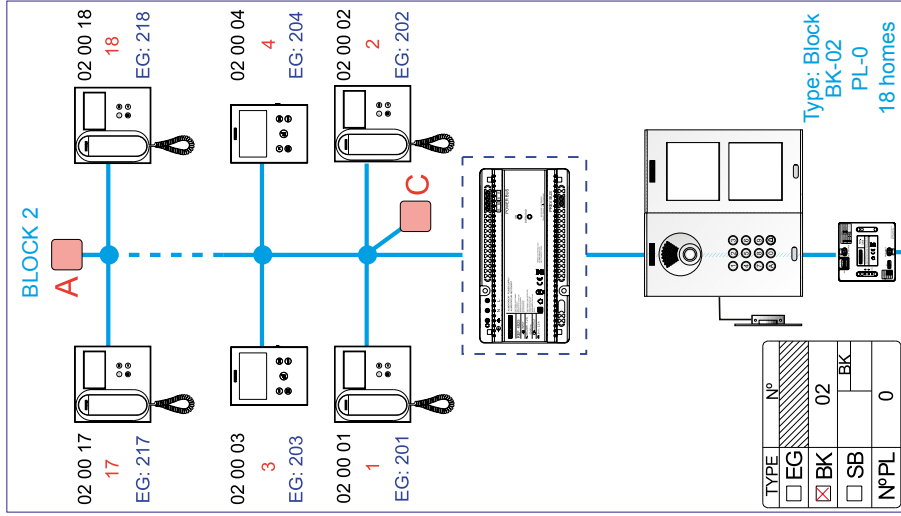
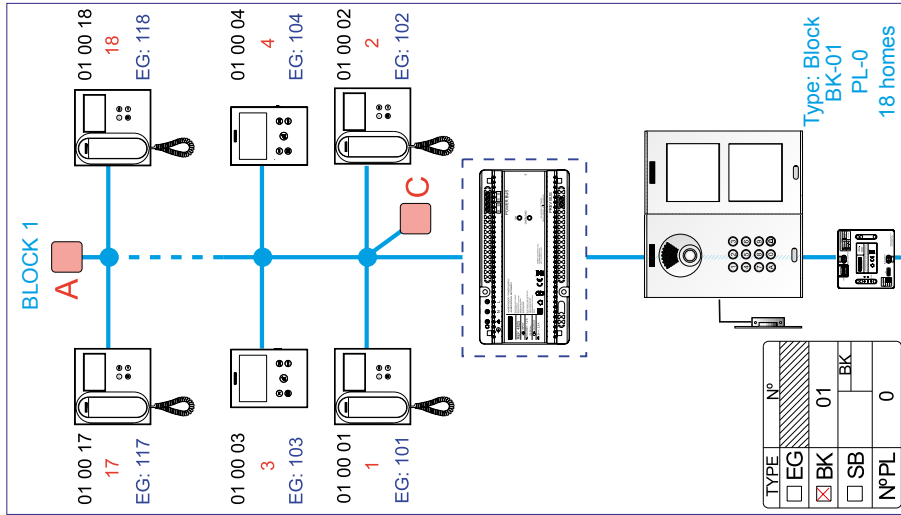

GENERAL ENTRANCE 3-DIGIT DIALLING / 4 digits in the event that there is a Block 10, 11, 12...99 (1001 - 1101 - 1201 ... 9901)
Create the mapping from the Extra Display Digital Outdoor Panel of the General Entrance.

- Mapping 010001 by 101
- Mapping 010002 by 102 and so forth until 010018 per 118
- Mapping 020001 by 201
- Mapping 020002 by 202 and so forth until 010018 per 218
- Mapping 030001 by 301
- Mapping 030002 by 302 and so forth until 010018 per 318

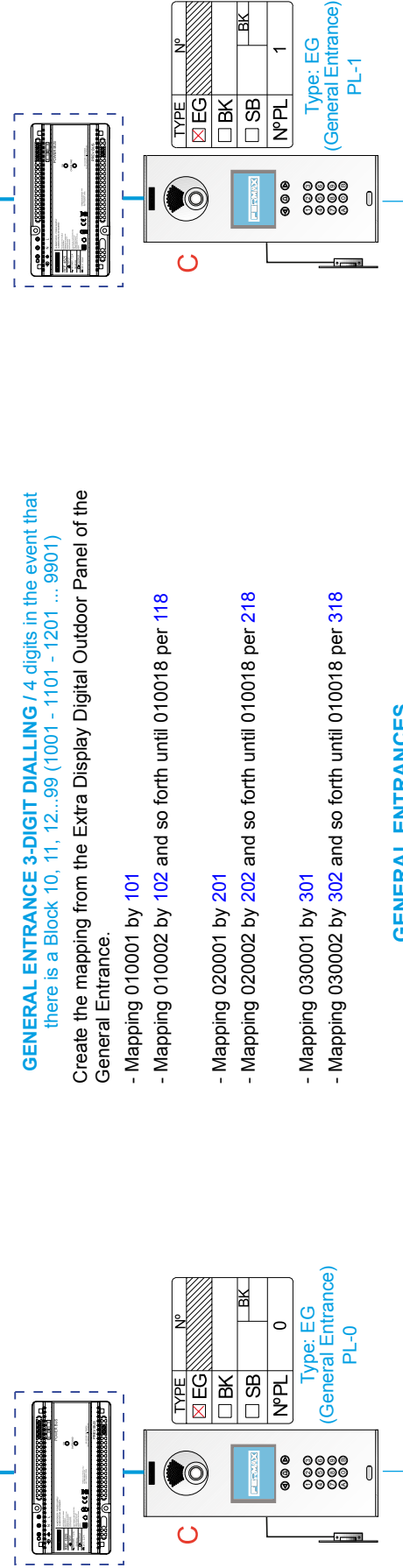

Example 3

INTERNAL BLOCKS (using a 5-digit call from the EG): 10001 - 20001 - 30001)

There can be up to **99 Blocks**.
Each block may have up to **9999 Apartments**.

DIALLING from the Direct Outdoor Panel of the Block: 1, 2, 3...18

The call can be placed in 2 ways:

- Dialling 5 digits as when calling from the EG:
- * 10001 ... 10018
- * 20001 ... 20018
- * 30001 ... 30018
- Dialling the number of the apartment (1, 2, 3...18).

Auto switch-on with Outdoor Panel 0 or 1 of the Block in question and also with Outdoor-Panel 0 of the General Entrance.
(Selected from the monitor).

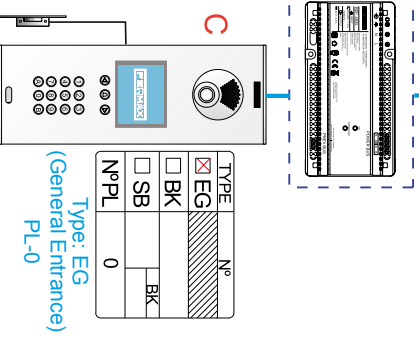
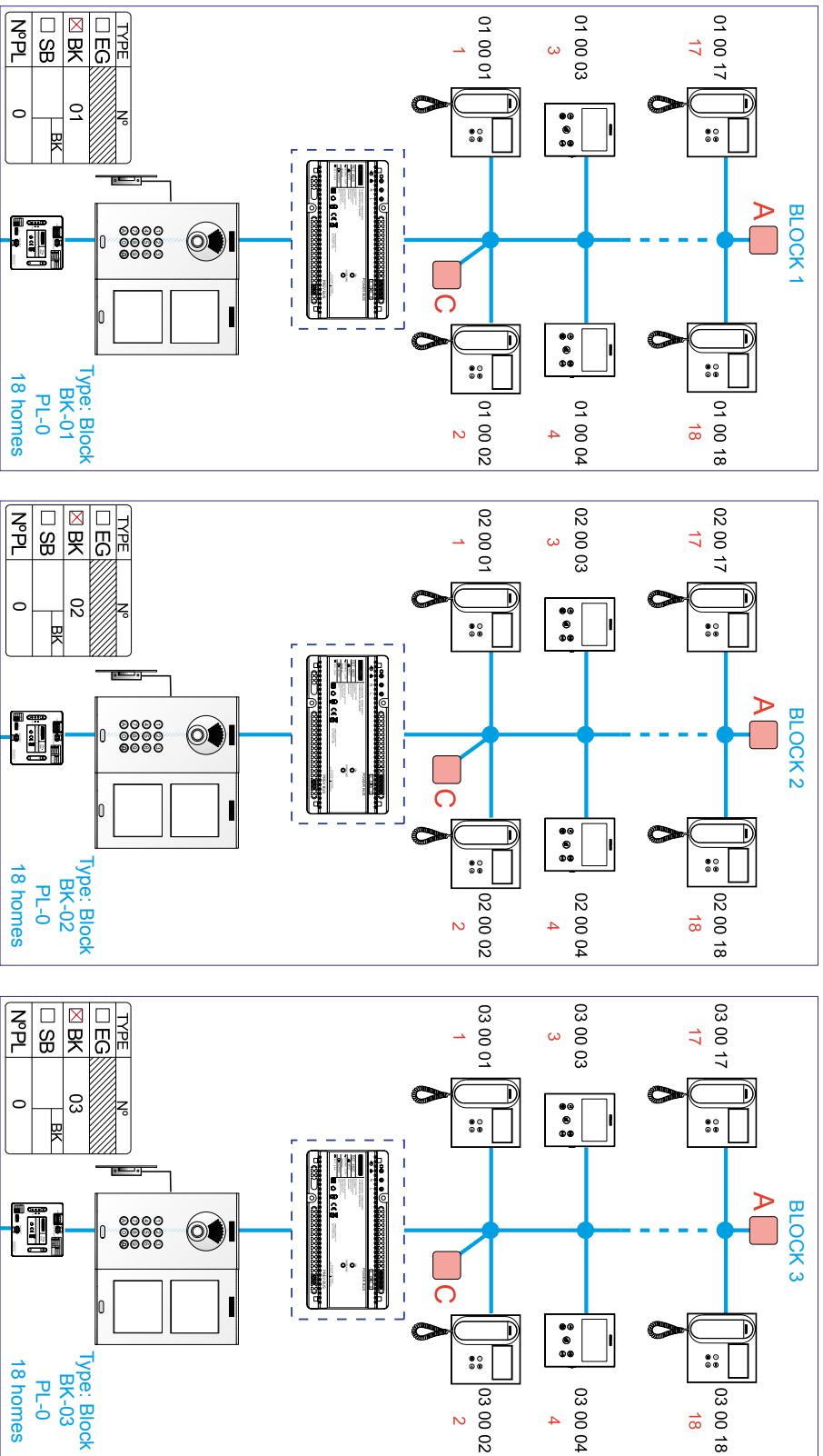

GENERAL ENTRANCE
5-DIGIT DIALLING / 6 digits in the event of there being a Block 10, 11, 12...99
(100001 - 110001 - 120001 ... 990001)

The call is made from the direct outdoor panel of the EG by pressing:

- Block 01: 10001 ... 10018.
- Block 02: 20001 ... 20018.
- Block 03: 30001 ... 30018.

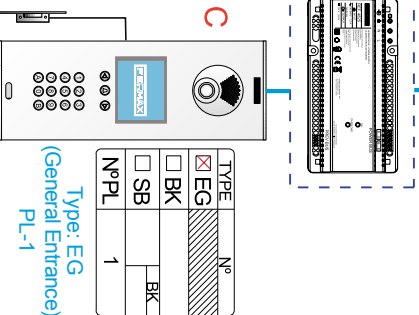

GENERAL ENTRANCES

Example 4

INTERNAL BLOCKS(using a 5-digit call from the EG)

There can be up to **99 Blocks**.

Each Block may have up to **9999 Apartments**,

DIALLING from the pushbutton panel of the BLOCK

The call is placed using the corresponding pushbutton (programmed as 1).

Auto switch-on with Outdoor Panel 0 or 1 of the Block in question and also with Outdoor Panel 0 of the General Entrance. (Selected from the monitor).

VILLA 6

BLOCK 6
06 00 01

Type: Block BK-06
PL-0

1 Apartment

TYPE	N°
<input type="checkbox"/> EG	06
<input checked="" type="checkbox"/> BK	BK
<input type="checkbox"/> SB	
N°PL	0

VILLA 5

BLOCK 5
05 00 01

Type: Block BK-05
PL-0

1 Apartment

TYPE	N°
<input type="checkbox"/> EG	05
<input checked="" type="checkbox"/> BK	BK
<input type="checkbox"/> SB	
N°PL	0

VILLA 4

BLOCK 4
04 00 01

Type: Block BK-04
PL-0

1 Apartment

TYPE	N°
<input type="checkbox"/> EG	04
<input checked="" type="checkbox"/> BK	BK
<input type="checkbox"/> SB	
N°PL	0

VILLA 3

BLOCK 3
03 00 01

Type: Block BK-03
PL-0

1 Apartment

TYPE	N°
<input type="checkbox"/> EG	03
<input checked="" type="checkbox"/> BK	BK
<input type="checkbox"/> SB	
N°PL	0

VILLA 2

BLOCK 2
02 00 01

Type: Block BK-02
PL-0

1 Apartment

TYPE	N°
<input type="checkbox"/> EG	02
<input checked="" type="checkbox"/> BK	BK
<input type="checkbox"/> SB	
N°PL	0

VILLA 1

BLOCK 1
01 00 01

Type: Block BK-01
PL-0

1 Apartment

TYPE	N°
<input type="checkbox"/> EG	01
<input checked="" type="checkbox"/> BK	BK
<input type="checkbox"/> SB	
N°PL	0

GENERAL ENTRANCE

5-DIGIT DIALLING / 6 digits in the event of Block 10, 11, 12...99
(100001 - 110001 - 120001 ... 990001)

The call is made from the direct outdoor panel of the EG by pressing:

Villas are considered as Blocks of 1 Apartment

Block 01 (Villa 1): 10001

Block 02 (Villa 2): 20001

Block 03 (Villa 3): 30001

Block 06 (Villa 6): 60001

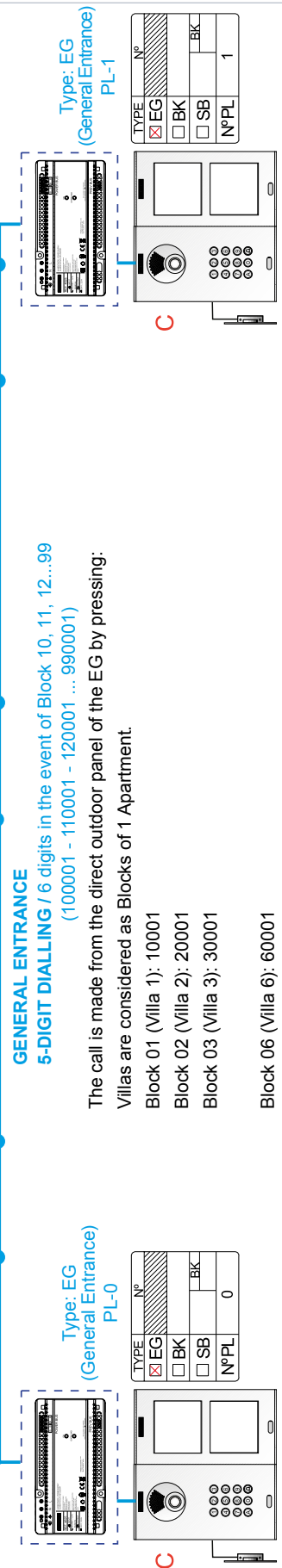

GENERAL ENTRANCES

Example 5

INTERNAL BLOCKS (using a 5-digit call from the EG): 10001 - 20001)

There can be up to **99 Blocks**.

Each Block may have **9999 Apartments**, (in pushbutton panels it is possible to programme the pushbuttons up to address 99).

DIALLING from the pushbutton panel of the BLOCK

Calls from the Block are placed using the corresponding pushbutton (programmed as 1, 2, 3...18).

Each Block may have up to **99 Sub-Blocks**.

On each floor there is one single-line outdoor panel per Apartment, which is programmed as a sub-block outdoor panel.

DIALLING from the pushbutton panel to the SUB-BLOCK

The call from the Sub-Block is placed using the pushbutton of the outdoor panel which should be mapped according to the apartment number (2, 3, 4 ... 18). The pushbutton of the outdoor panel of apartment 1 is the only one which corresponds.

As the sub-block number (00) is common to the entire block, it is the numbers of the outdoor panel of the sub-block which change.

AUTO SWITCH-ON

Auto switch-on with Outdoor Panel 0 or 1 of the Block in question and also with Outdoor Panel 0 of the General Entrance.

(Selected from the monitor).

There is no Auto Switch-On feature in Sub-Block outdoor panels.

BUILDING 1

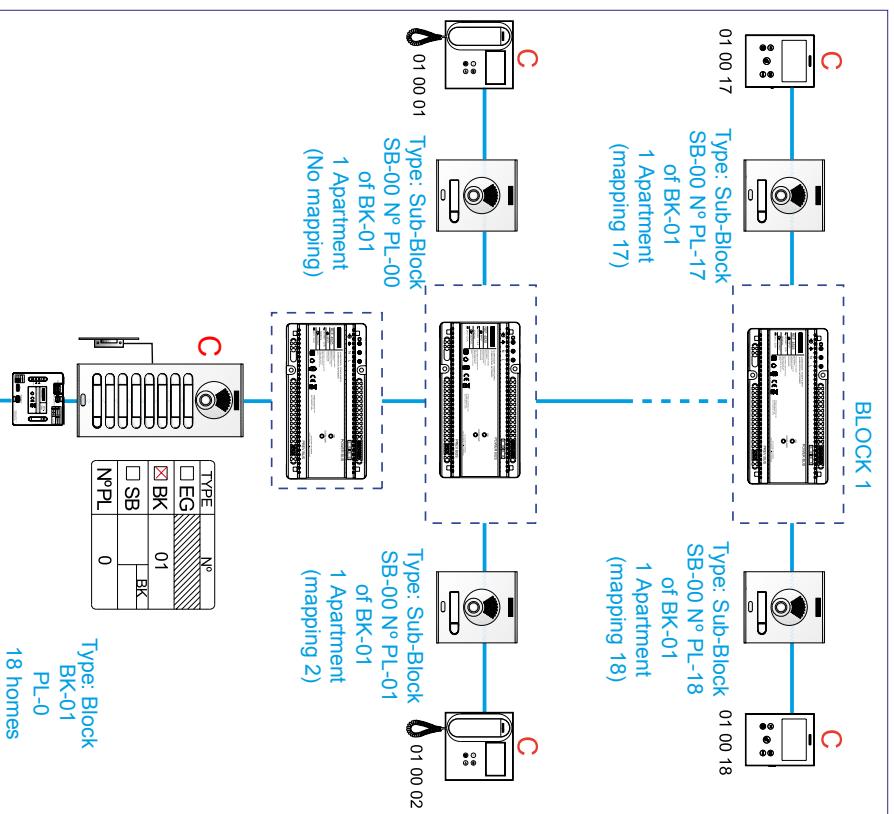

BUILDING 2

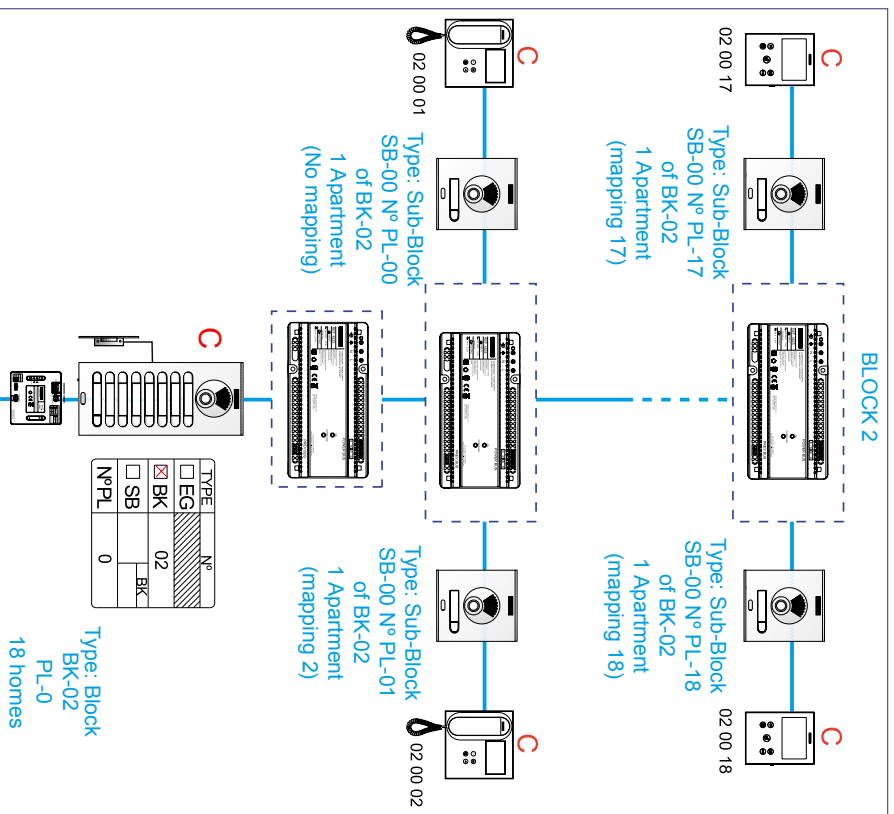

GENERAL ENTRANCE

5-DIGIT DIALLING / 6 digits in the event of there being a Block 10, 11, 12... 99 (100001 - 110001 - 120001 ... 990001)

The call is made from the direct outdoor panel of the EG by pressing:

Block 01: 10001 ... 10018.

Block 02: 20001 ... 20018.

GENERAL ENTRANCES

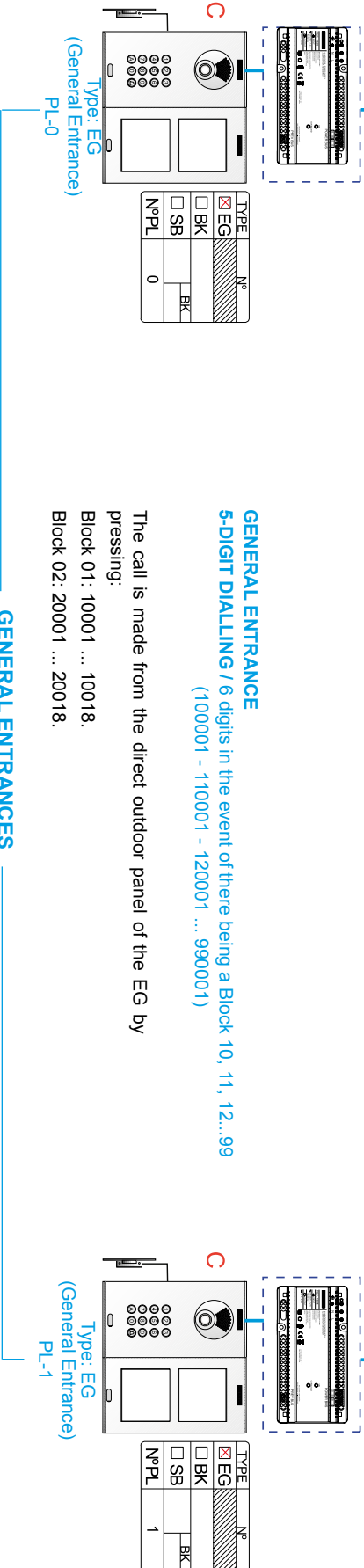

Example 6

INTERNAL BLOCKS (using a 5-digit call from the EG): 10001 - 20001

There can be up to **99 Blocks**.

Each block may have up to **9999 Apartments**.
DIALLING from the Direct Outdoor Panel of the Block: Sub-Block + Apartment; 0101, 0201 ... 1801

The call can be placed in 2 ways:

- Dialling 5 digits as when calling from the EG:
 * 10101, 10201, 10301 ... 11801
 * 20101, 20201, 20301 ... 21801
 * 30001 ... 30018
- Dialling the number of the Sub-Block + Apartment (the Block numbers can be omitted): 101, 201 ... 1801

On each floor there is one single-line outdoor panel per Apartment, which is programmed as a sub-block outdoor panel.

DIALLING from the pushbutton panel to the SUB-BLOCK

The call from the Sub-Block is placed using the pushbutton of the outdoor panel (with this type of coding there is no need to map the pushbutton of the outdoor panel). This means that the number of the outdoor panel is the same (00) in the different apartments in the block. What changes are the numbers of the sub-blocks.

AUTO SWITCH-ON

Auto switch-on with Outdoor Panel 0 or 1 of the Block in question and also with Outdoor Panel 0 of the General Entrance.

(Selected from the monitor).

There is no Auto Switch-On feature in Sub-Block outdoor panels.

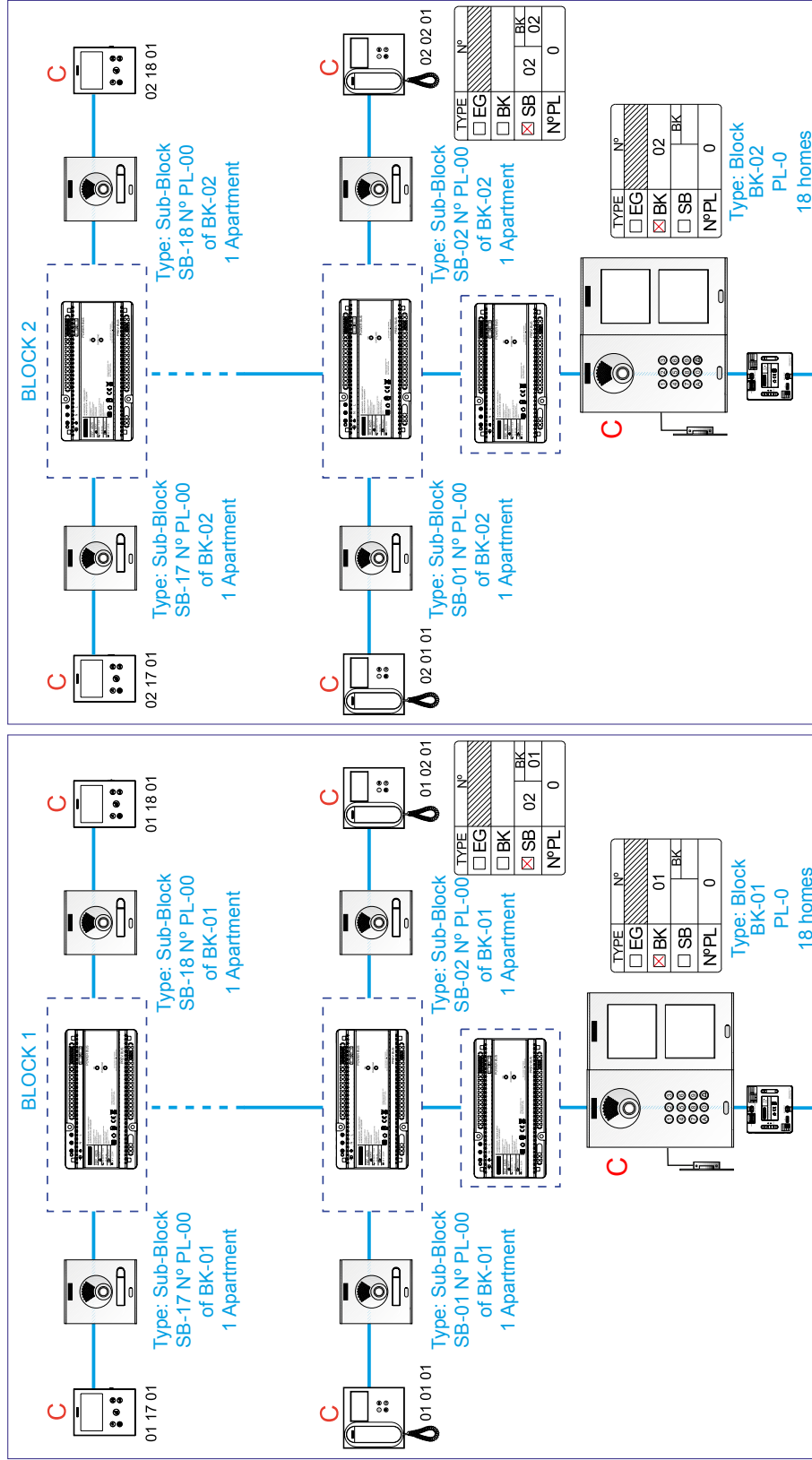

GENERAL ENTRANCE 5-DIGIT DIALLING / 6 digits in the event of there being a Block 10, 11, 12...99
 (100101 - 110101 - 120101 ... 990101)

The call is placed from the direct outdoor panel of the EG by dialling (Block No. + Sub-Block No. + Apartment No.):

Block 01: 10101, 10201, 10301 ... 11801.

Block 02: 20101, 20201, 10301 ... 21801.

Block 99: 990101, 990201, 990301 ... 991801.

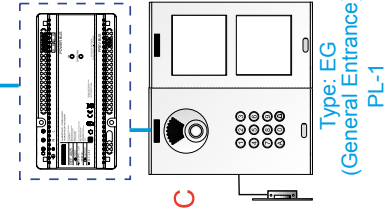
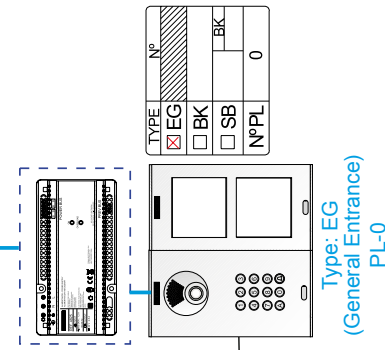

GENERAL ENTRANCES

2. DUOX PLUS OUTDOOR PANELS.

All of the DUOX video door panels include a video amplifier with a highly sensitive wide-angle camera incorporating a focus regulation system as standard. The audio amplifier is incorporated in the audio door panels.

The amplifier manages all of the functions of an installation (calling, communication in both directions, door release, programming and so on).

These are available in all of the FERMAX styles: Cityline, Skyline and Marine.

As a new feature that was not present on previous versions, the DUOX PLUS video amplifiers now have a digital microphone integrated into the amplifier module. By contrast, DUOX PLUS audio amplifiers still use the microphone that is mounted on the frame of the panel.

Depending on their function (the way in which they make the call) and the intrinsic specifications of the model, the outdoor panels may be: Pushbuttons, Direct or Digital.

The digital outdoor panels incorporate a high-brightness 3.5" EXTRA DISPLAY for outdoor environments, which aids usage and boosts the outdoor panel's possibilities.

The DUOX PLUS amplifier incorporates a voice-guided programming system which facilitates the configuration and commissioning of the installation in the pushbutton panels. It also includes a voice synthesiser as standard. When actuated, the lock release issues the message: "Door open. Please close after entering".

Outdoor panels with different aesthetics:

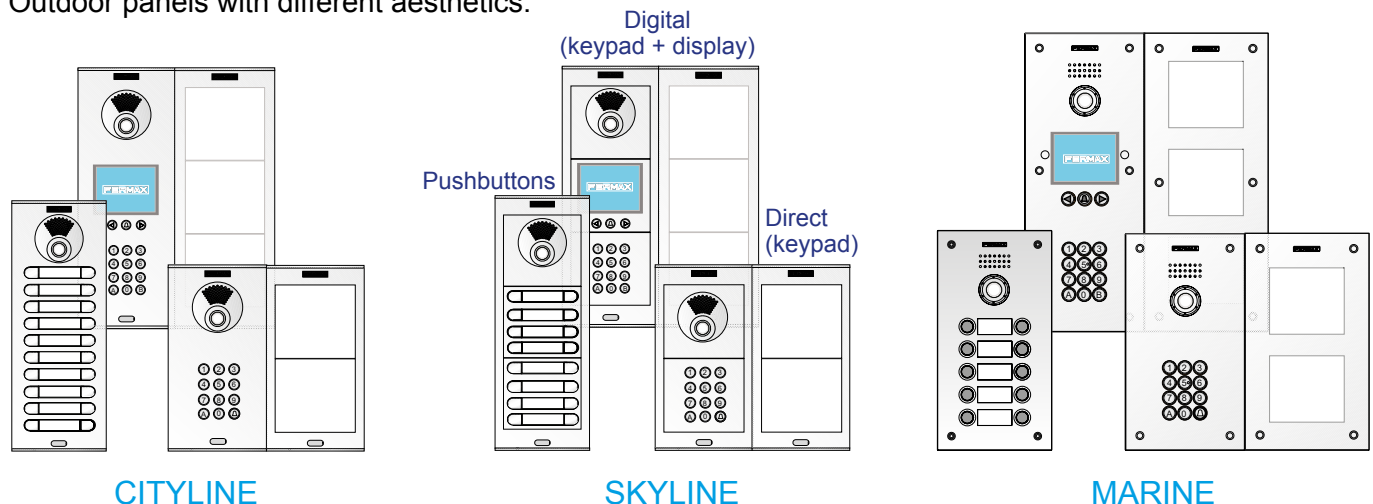

2.1 DUOX PLUS AMPLIFIERS

Several different DUOX PLUS amplifier models are included in the outdoor panels depending on the type of panel. Regardless of the outdoor panel model, they are compatible with one another and can therefore coexist within the same installation.

Amplifier models and outdoor panels in which they are included:

2.1.1 Video Amplifier for Cityline and Marine Outdoor Panels with Pushbuttons

- * Cityline Video Outdoor Panels with Pushbuttons.
- * Marine Video Outdoor Panels with Pushbuttons.

2.1.2 Video Amplifier for Skyline, Direct and Digital Outdoor Panels.

- * Skyline Video Outdoor Panels: with Pushbuttons, Direct and Digital.
- * Cityline Video Outdoor Panels: Direct and Digital.
- * Marine Video Outdoor Panels: Direct and Digital.

2.1.3 Audio Amplifier for Cityline and Marine Outdoor Panels with Pushbuttons

- * Cityline Audio Outdoor Panels with Pushbuttons.
- * Marine Audio Outdoor Panels with Pushbuttons.

2.1.4 Audio Amplifier for Skyline, Direct and Digital Outdoor Panels.

- * Skyline Audio Outdoor Panels: with Pushbuttons, Direct and Digital.
- * Cityline Audio Outdoor Panels: Direct and Digital.
- * Marine Audio Outdoor Panels: Direct and Digital.

2.1.1 VIDEO AMPLIFIER FOR CITYLINE AND MARINE OUTDOOR PANELS WITH PUSHBUTTONS

a) SETTINGS

1a) Outdoor panel settings

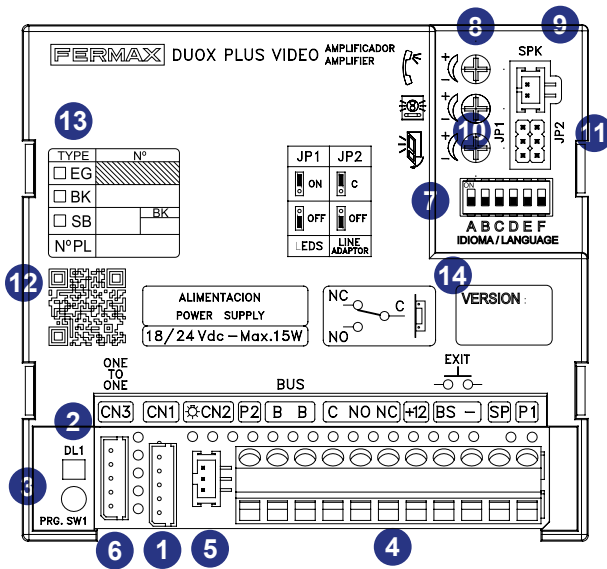

- 1 CN1 (5 pins)**
Connection call extension module.
- 2 DL1: Status Led**
Intermittent slow blinking. Inverse or Sequential Programming (mapping of pushbutton panels).
Shut down. Standby.
- 3 SW1 button**
- 4 Panel Connectors:**
B,B: DUOX Bus: power supply, data, audio and video.
C, NO, NC: Relay dry contact (Max 2A@30Vdc).
+12: output 12 Vdc-250mA (maximum 500mA for 100 seconds).
BS, -: exit button.
SP, -: door sensor input.
P1, P2: Integrated button connections.
- 5 CN2: Individual connection buttons for continuous profile Cityline panel.**
- 6 CN3: OneToOne Module Connection**
- 7 Language selection¹**
of the "door open" message.
- 8 Audio setting**
of the Monitor/Telephone, the outdoor panel and the door open.
- 9 SPK: Loudspeaker connection**
- 10 JP1: Camara LEDs**
LEDS ON. switched on when the camera is activated.
LEDS OFF. always switched off.
- 11 JP2: Line adapter**
Integrated in the amplifier for potential use.
- 12 QR Code**
- 13 Programming details label**
- 14 Amplifier version**

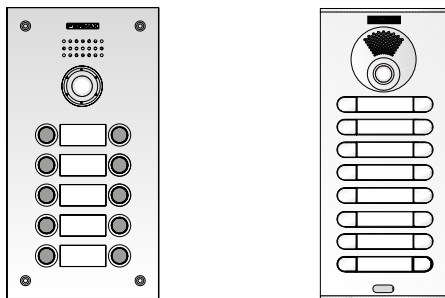

¹Door open' warning language selection

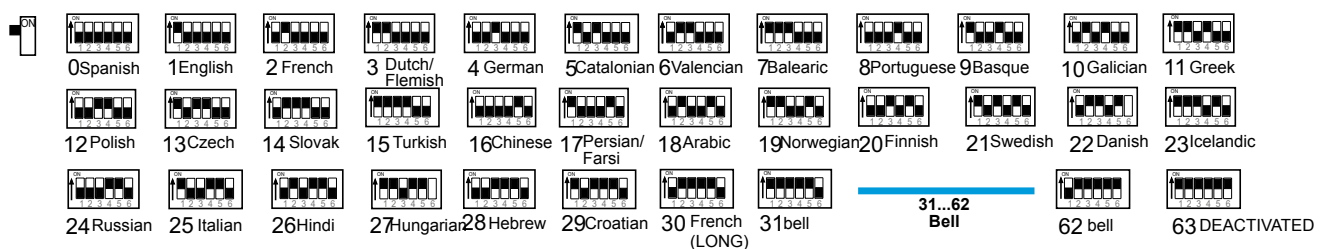

2a) Configuration as master outdoor panel

Required in the event that it is necessary to program the apartment terminal. The panels will be in Master Mode by default.

Pressing the SW1-PROG button 3 times in a row will activate the panel in MASTER mode, and a voice prompt will sound, indicating "MASTER". If the voice prompt "SLAVE" sounds when the SW1-PROG button is pressed 3 times in a row, it means that Master Mode has been deactivated.

Once the terminal configuration is completed, it is recommended that the MASTER panel be deactivated to prevent the terminals from being re-programmed accidentally.

Notes:

In any installation, there can only be one MASTER plate at any one time, regardless of whether it is a single block or multi-block installation, or whether it is configured as a sub-block, block or general input panel. When an outdoor panel is configured as MASTER, it will inform the rest of the installation. If a different outdoor panel has previously been configured as master, it will then cease to be configured as such.

3a) Outdoor panel coding*

Whenever there is more than one outdoor panel, it will be necessary to program the number of outdoor panels.

4a) Camera focus / Lock release activation time*

This adjusts the camera image or adjusts the door opening time.

*Note: Check sub-section 2b) Voice-assisted configuration in pushbutton panels.

5a) Technical specifications of the amplifier

Power supply	18 - 24 Vdc
Standby consumption	2,86 W
Maximum active audio consumption	6,30 W
Audio power in the apartment-outdoor panel direction	1 W
Audio power in the outdoor panel-apartment direction	0,15 W
Operating temperature	[-25° , +70°C] / [-13° , 158°F]
Volume adjustable in both directions	
Video	
Resolution	QVGA (360x280) pixels
Sensor	1/3" CMOS colour
Effective number of pixels	340K
Minimum exterior lighting	0.5 lux
S/N relation	>45dB
Picture refresh	= 25 fps
Auto iris	
Automatic backlighting setting	
Vision angle	100° H, 80°V

Vision in night colour with white LEDs

6a) Outdoor panel amplifier parameters

Lock release activation time	01...99 sec. (by default: 03)
Exit button activation time	00...99 sec. (by default: 06) / (deactivated: 00)
Maximum conversation time	90 sec.
Type of outdoor panel	sub-block/block/general entrance. (by default: block)
Block Number	00..99, (by default: 00)
Sub-Block Number	00..99, (by default: 00)
Outdoor Panel Number	0..9, (by default: 0)
Door sensor time	000..250, (by default: 000, non-active)
Volume monitoring	0..9, (by default: 5)
MASTER mode	
Mapping	
Sequential programming time of pushbuttons following halt of activity	60 sec.
Inverse programming time of pushbuttons following halt of activity	300 sec.

 b) CONFIGURATION

The DUOX PLUS amplifier includes "Restore" and "Change Value" functions which enable users to restore/change the parameters that have been programmed.

1b) Reset of the mapping of the call code of the pushbuttons

In order to reset the mapping that has been made:

- Remove the power supply.
- Press the SW1 programming button to supply power to the amplifier and hold this button down for 5 seconds. You should hear a "beep" sound. The Led (DL1) will blink rapidly to indicate that the restore process has taken place.

Note: This mapping reset function is for all of the outdoor panels with PUSHBUTTONS regardless of the aesthetic design:

- Cityline outdoor panels
- Marine outdoor panels
- Skyline outdoor panels

2b) Voice-assisted configuration in pushbutton panels

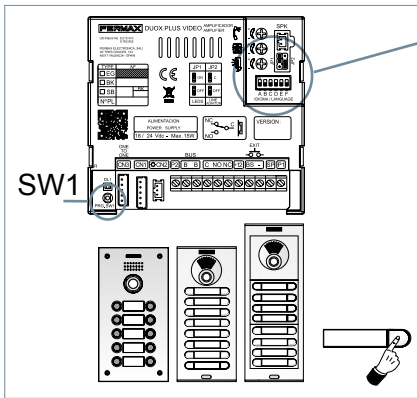

Selection of the language of voice messages by means of the **Synthesiser**. (Languages available: Spanish, English, French, German, Italian and Portuguese).

Note: Voice-assisted configuration is for all of the outdoor panels with **PUSHBUTTONS** regardless of the aesthetic design:

- Cityline outdoor panels
- Marine outdoor panels
- Skyline outdoor panels

1. Access the configuration by pressing SW1 4 times in a row. The amplifier will reproduce the "CONFIGURATION" message and will initiate the process.

In order to exit the configuration process you may press and hold SW1 for 5 seconds, or the process will be exited automatically if no activity is detected for 30 seconds. The amplifier will play the message "END CONFIGURATION" and return to standby mode.

See diagram.

2. Pressing SW1 will move through the different parameters and will reproduce the following by voice: **parameter and current configured value**.

Once the message has been reproduced, pressing on any call button will modify the value (a BEEP will be heard each time the button is pressed and the value will rise).

Once the entry has been completed it is possible to listen to the reproduction of the new value by allowing 5 seconds to elapse without pressing anything. When the value of the parameter reaches the maximum possible value, a "BOOP" sound will be heard and the value will be situated in the minimum possible of this parameter.

3. Pressing on the call button for 5 seconds will create a "BOOP" sound and the parameter, when this is the selection of a number, will be located at its minimum value and if it is a type of value it will be reset to the default value.

DIAGRAM

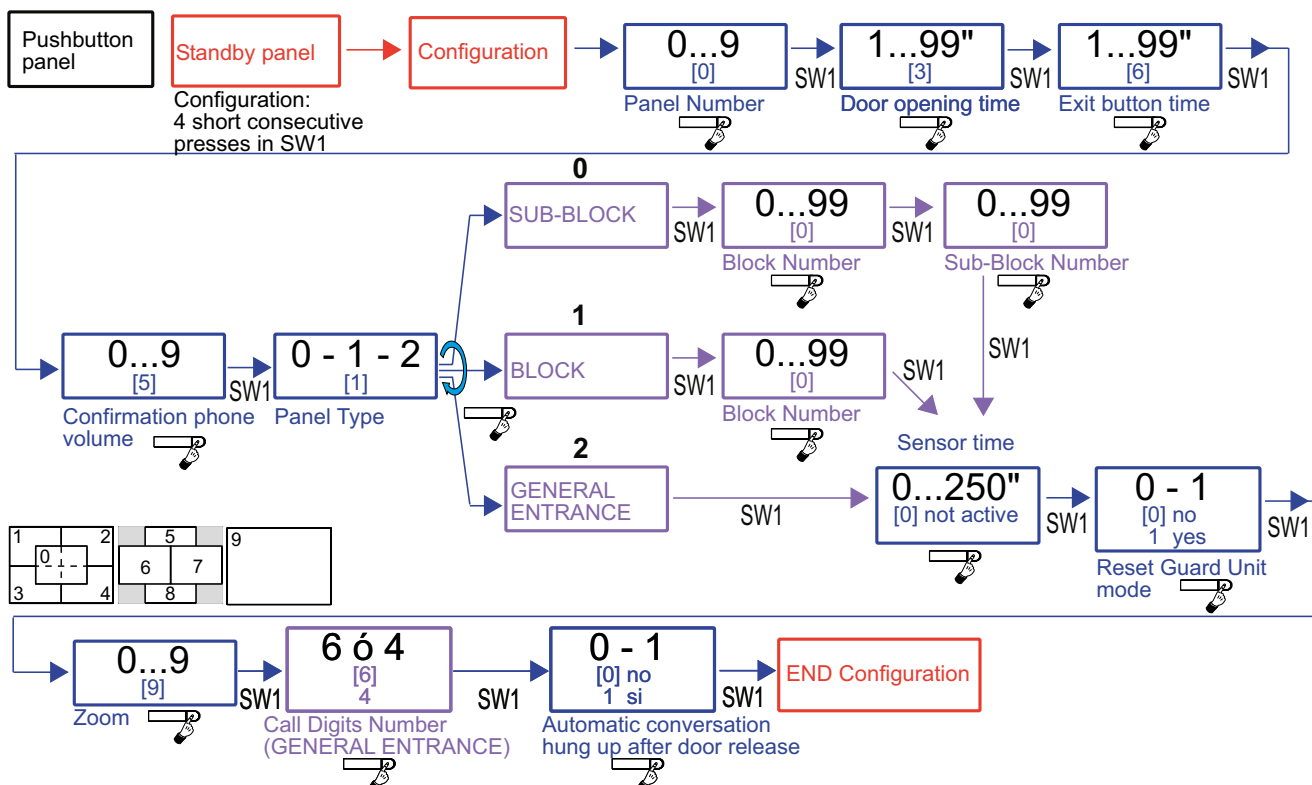

 c) PRE-WIRING

1c) Call extension module

One of the benefits of the DUOX system is the fact that it does not use call wires. This is made possible by the fact that the call is placed through the transmission of a digital code which is generated by the outdoor panel amplifier when a given call button is pressed.

In pushbutton panels (Cityline and Marine), one or more call extension modules are used to generate the specific code for each one of the calls. This module converts the pressing of each button on the outdoor panel into a call code.

The call code that is generated by the pushbutton is determined by the connection from the pushbutton to the call extension module.

There are 2 call extension modules:

- Ref. 2441 16-pushbutton call extension module.
- Ref. 2008 8-pushbutton call extension module.

Cityline/Marine kit panels with 1 and 2 pushbuttons

The Cityline/Marine kit panels with 1 and 2 pushbuttons do not require the installation of the call extension module.

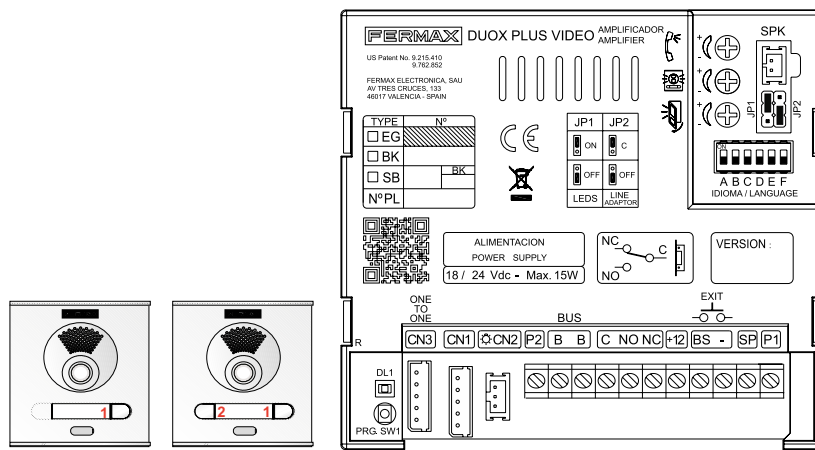

CITYLINE outdoor panel pre-wiring
 Connection of call extension module Ref. 2441.

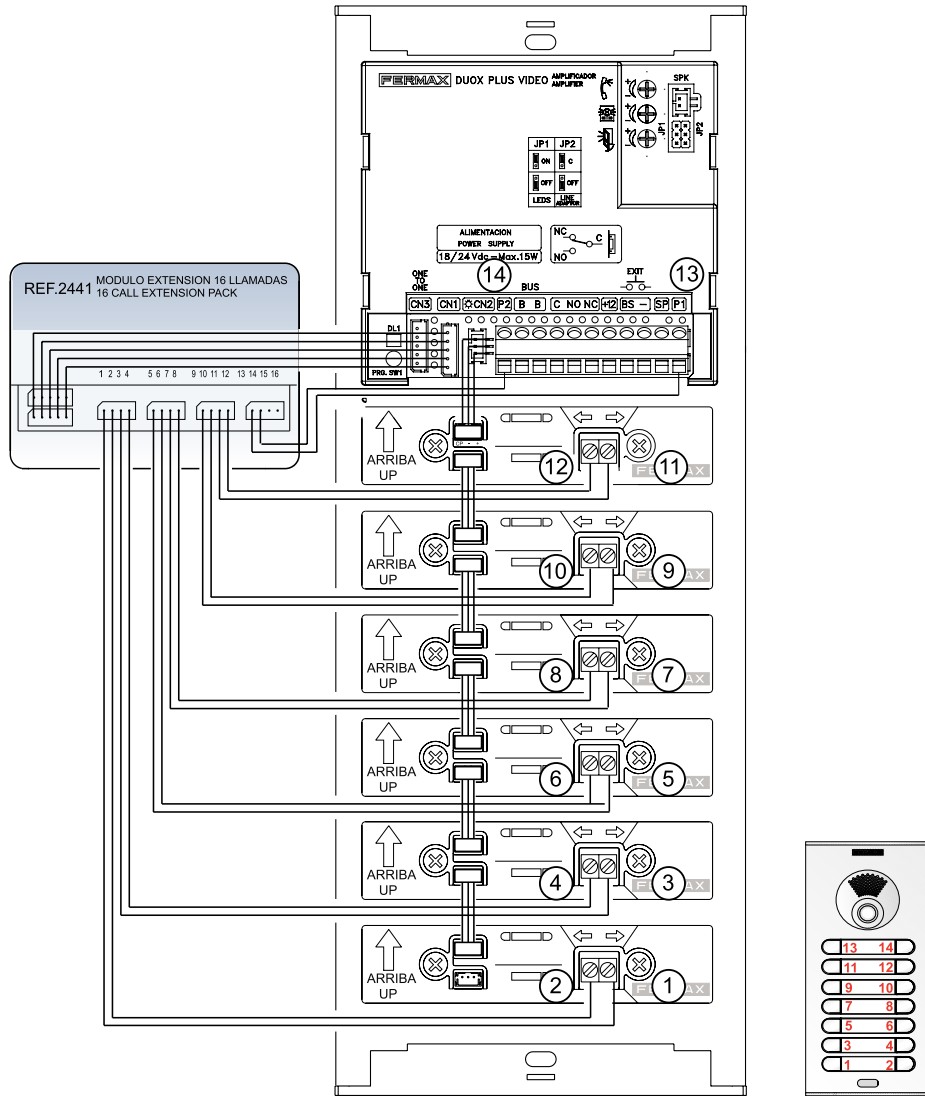

Connection of several call extension modules (more than 16 pushbuttons)

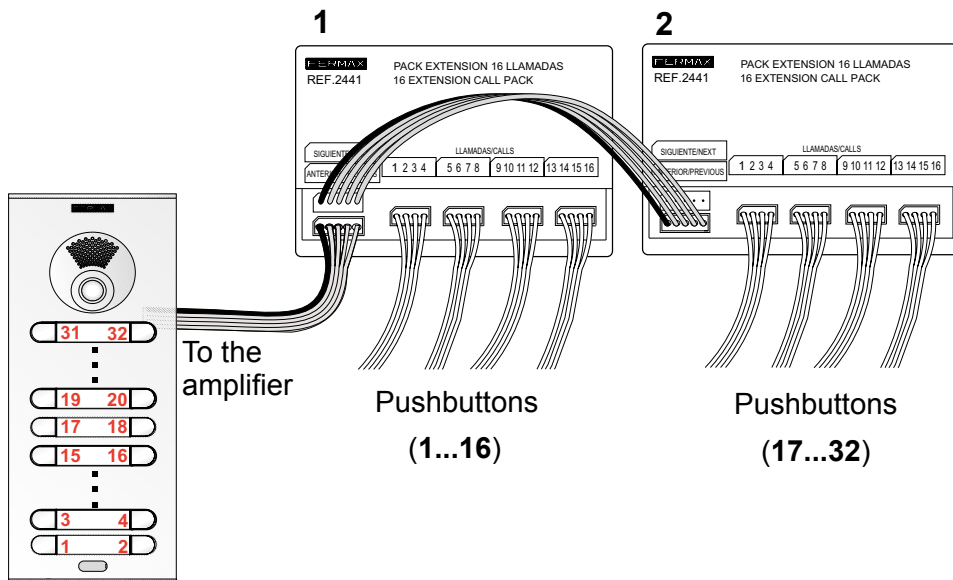

CITYLINE outdoor panel pre-wiring
 Connection of call extension module Ref. 2008.

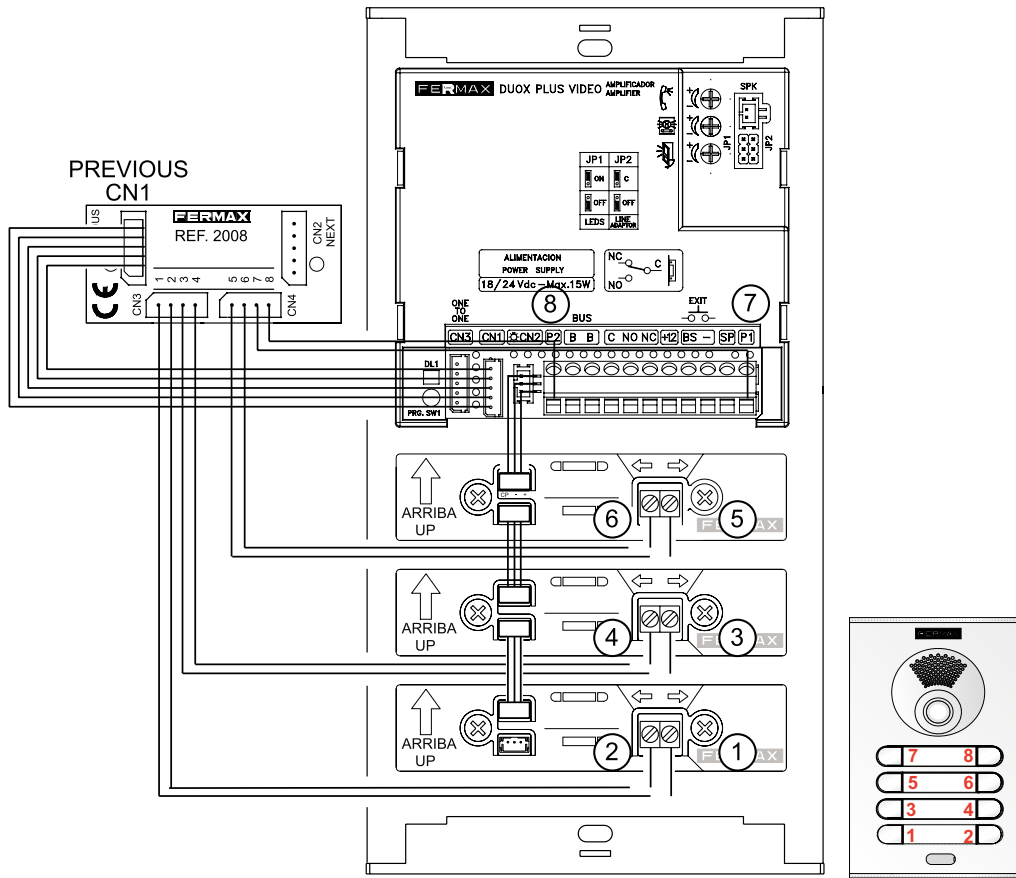

Connection of several call extension modules (more than 8 pushbuttons)

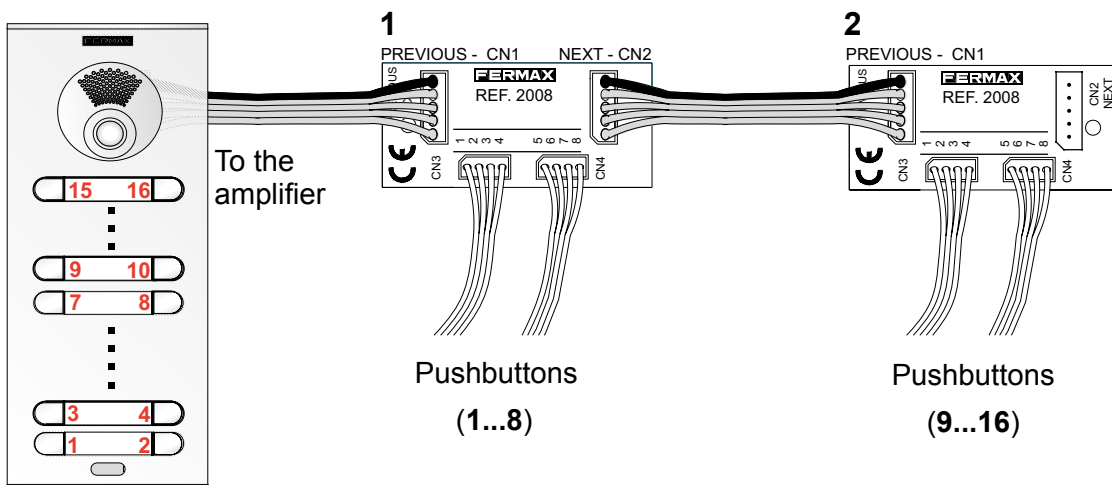

MARINE outdoor panel pre-wiring
 Connection of call extension module Ref. 2441.

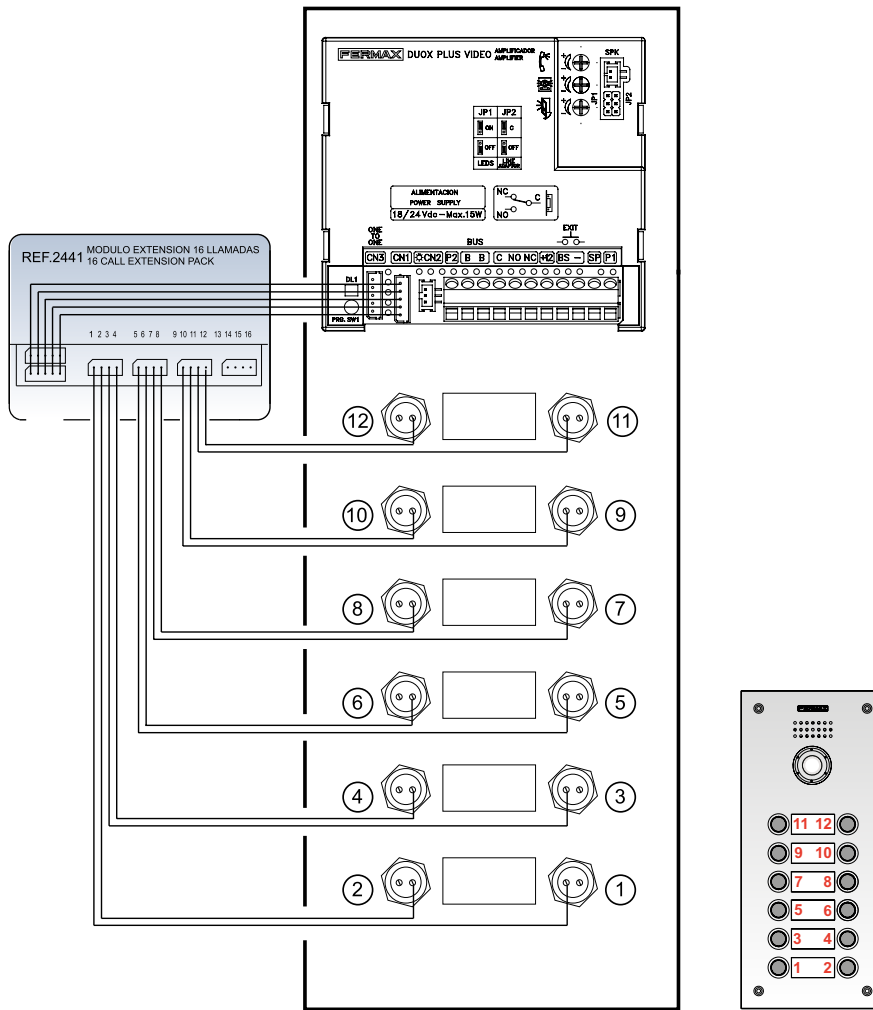

Connection of several call extension modules (more than 16 pushbuttons)

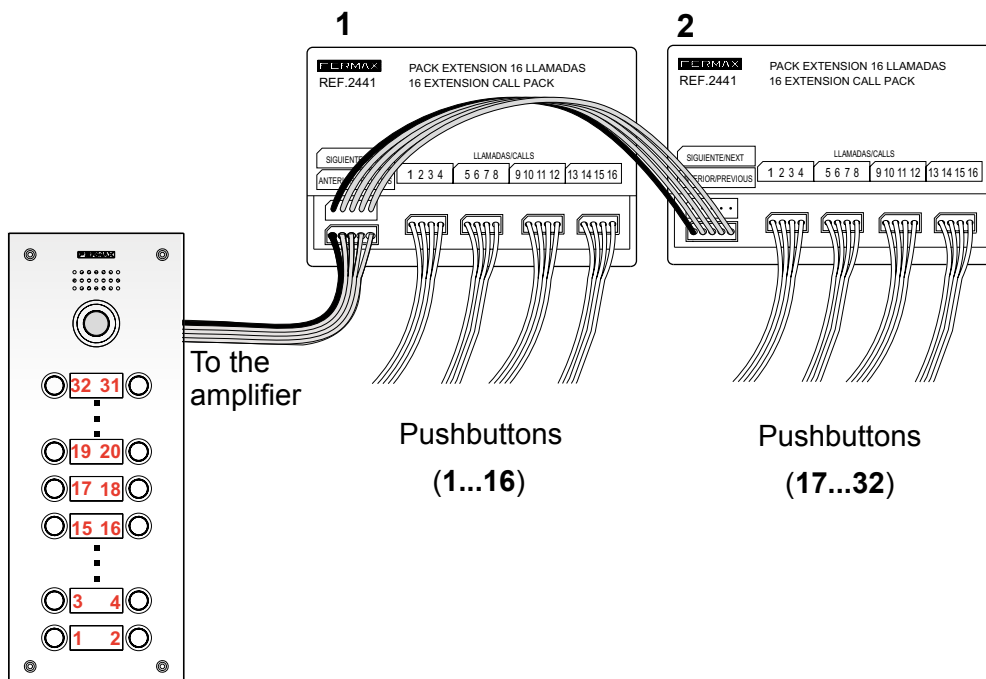

MARINE outdoor panel pre-wiring
 Connection of call extension module Ref. 2008.

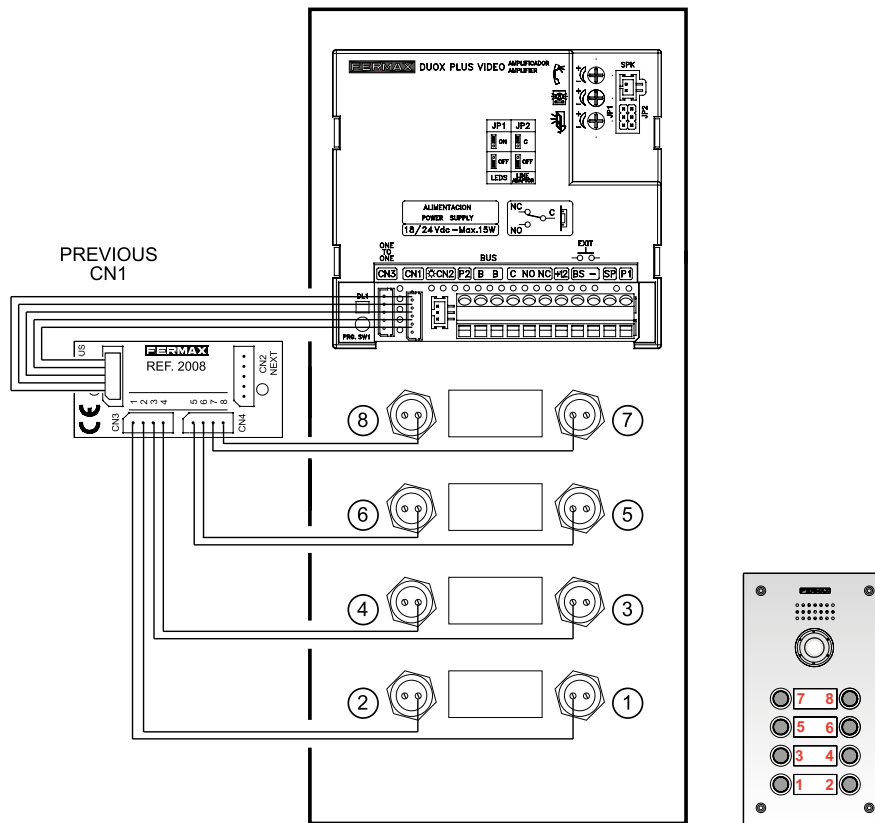

Connection of several call extension modules (more than 8 pushbuttons)

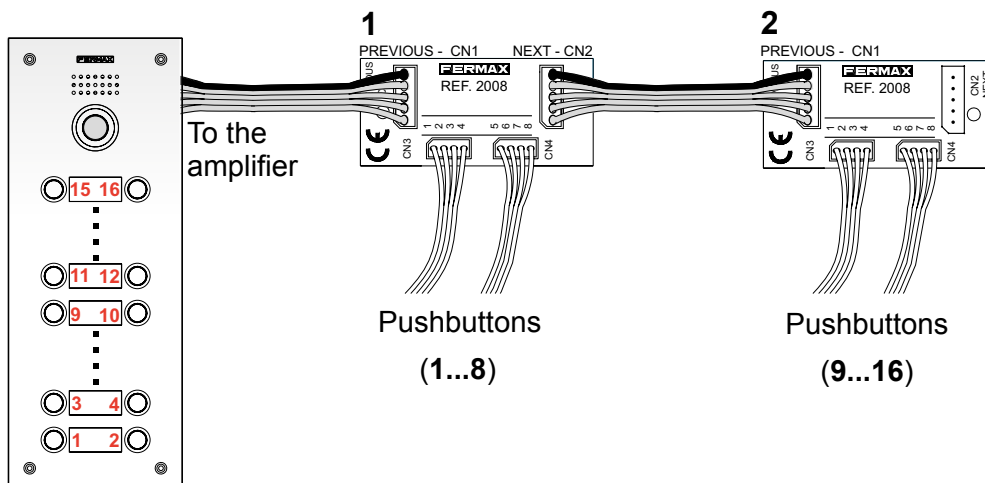

Notes:

- In the event that it is necessary to accommodate a larger amount of pushbuttons, two or more modules may be used, up to the total of the 99 apartments that enable the DUOX system in pushbutton panels.
- The assignment of call codes by the call extension module may be modified using the "Mapping" function which is available in the DUOX amplifier. [See subsection 2.2 Advanced Programming.](#)

2.1.2 VIDEO AMPLIFIER FOR SKYLINE, DIRECT AND DIGITAL OUTDOOR PANELS

a) SETTINGS

1a) Outdoor panel settings

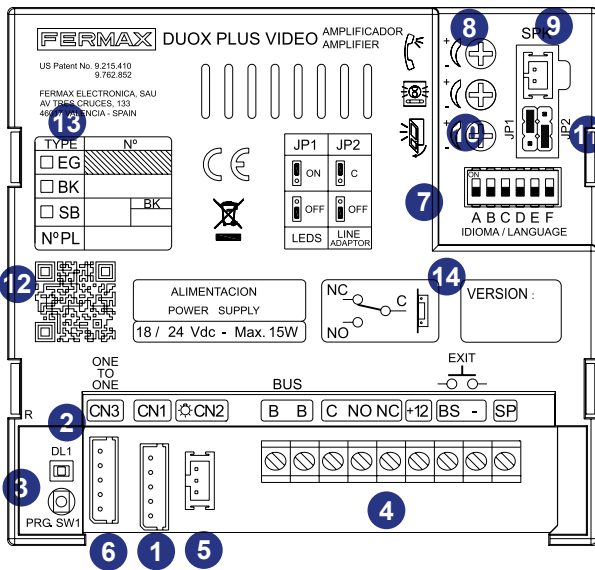

- 1 CN1 (6 pins)**
Connection of modular push buttons keypads and display.
- 2 DL1: Status Led**
Intermittent slow blinking. Inverse or Sequential Programming (mapping of pushbutton panels).
Shut down. Standby.
- 3 SW1 button**
- 4 Panel Connectors:**
B,B: DUOX Bus: power supply, data, audio and video.
C, NO, NC: Relay dry contact (Max 2A@30Vdc).
+12: output 12 Vdc-250mA (maximum 500mA for 100 seconds).
BS, -: exit button.
SP, -: door sensor input.
- 5 CN2: Individual connection buttons for continuous profile Cityline panel.**
- 6 CN3: OneToOne Module Connection**
- 7 Language selection¹**
of the "door open" message.
- 8 Audio setting**
of the Monitor/Telephone, the outdoor panel and the door open.
- 9 SPK: Loudspeaker connection**
- 10 JP1: Camara LEDs**
LEDS ON. switched on when the camera is activated.
LEDS OFF. always switched off.
- 11 JP2: Line adapter**
Integrated in the amplifier for potential use.
- 12 QR Code**
- 13 Programming details label**
- 14 Amplifier version**

	DIRECT	DIGITAL	PULSADOR
CITYLINE			
SKYLINE			
MARINE			

¹Door open¹ warning language selection

2a) Configuration as master outdoor panel

- Pushbutton panels:

Required in the event that it is necessary to program the apartment terminal. The panels will be in Master Mode by default.

Pressing the SW1-PROG button 3 times in a row will activate the panel in MASTER mode, and a voice prompt will sound, indicating "MASTER". If the voice prompt "SLAVE" sounds when the SW1-PROG button is pressed 3 times in a row, it means that Master Mode has been deactivated.

Once the terminal configuration is completed, it is recommended that the MASTER panel be deactivated to prevent the terminals from being re-programmed accidentally.

Notes:

In any installation, there can only be one MASTER plate at any one time, regardless of whether it is a single block or multi-block installation, or whether it is configured as a sub-block, block or general input panel.

When an outdoor panel is configured as MASTER, it will inform the rest of the installation. If a different outdoor panel has previously been configured as master, it will then cease to be configured as such.

- Direct outdoor panels: Check [3b\) Configuration table in direct outdoor panels \(subsequent pages\)](#).
- Digital outdoor panels: Check [4b\) Basic configurations of the extra display \(subsequent pages\)](#).

3a) Outdoor panel coding*

Whenever there is more than one outdoor panel, it will be necessary to program the number of outdoor panels.

4a) Camera focus / Lock release activation time*

This adjusts the camera image or adjusts the door opening time.

*Note: Consult the relevant sub-section for the type of panel in question:

- Pushbutton panel: [2b\) Voice-assisted configuration in pushbutton panels \(previous pages\)](#).
- Direct outdoor panel: [3b\) Configuration table in direct outdoor panels \(subsequent pages\)](#).
- Digital outdoor panel: [4b\) Basic configurations of the extra display \(subsequent pages\)](#).

5a) Technical specifications of the amplifier

Power supply	18 - 24 Vdc
Standby consumption	2,86 W
Maximum active audio consumption	6,30 W
Audio power in the apartment-outdoor panel direction	1 W
Audio power in the outdoor panel-apartment direction	0,15 W
Operating temperature	[-25° , +70°C] / [-13° , 158°F]
Volume adjustable in both directions	
Video	
Resolution	QVGA (360x280) pixels
Sensor	1/3" CMOS colour
Effective number of pixels	340K
Minimum exterior lighting	0.5 lux
S/N relation	>45dB
Picture refresh	= 25 fps
Auto iris	
Automatic backlighting setting	
Vision angle	100° H, 80°V
Vision in night colour with white LEDs	

6a) Outdoor panel amplifier parameters

Lock release activation time	01...99 sec. (by default: 03)
Exit button activation time	00...99 sec. (by default: 06) / (deactivated: 00)
Maximum conversation time	90 sec.
Type of outdoor panel	sub-block/block/general entrance. (by default: block)
Block Number	00..99, (by default: 00)
Sub-Block Number	00..99, (by default: 00)
Outdoor Panel Number	0..9, (by default: 0)
Door sensor time	000..250, (by default: 000, non-active)
Volume monitoring	0..9, (by default: 5)
MASTER mode	
Mapping (pushbutton panel)	
Sequential programming time of pushbuttons following halt of activity	60 sec.
Inverse programming time of pushbuttons following halt of activity	300 sec.
Programming code (direct outdoor panel)	0000..9999, (by default: 4444)
Opening code (direct outdoor panel)	0000..9999, (by default: non-active)

b) CONFIGURATION

The DUOX PLUS amplifier includes “Restore” and “Change Value” functions which enable users to restore/change the parameters that have been programmed.

SKYLINE PUSHBUTTON PANEL

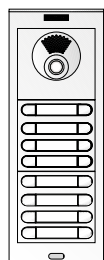

1b) Reset of the mapping of the call code of the pushbuttons

2b) Voice-assisted configuration in pushbutton panels

Note: See chapter 2.1.1 VIDEO AMPLIFIER FOR CITYLINE AND MARINE PANELS WITH PUSHBUTTONS, sub-section b) CONFIGURATION.

DIRECT OUTDOOR PANELS

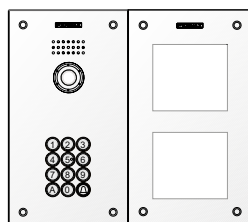
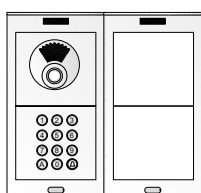
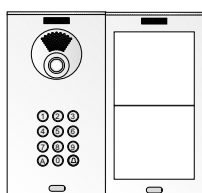

3b) Configuration table in direct outdoor panel

The parameters can be configured using the keypad. In order to do this it is necessary to enter configuration mode using a programming access code after pressing ‘A’.

Entering programming: **A + 4444** (Default programming access code).

If the code is correct, a confirmation tone will sound (beep-beep).

Parameters that may be configured:

Position	Adjust Parameter	Values [default]	Comment
01	Time activ. lock releases	01-99" [03]	Relay activation of lock releases from home or access control.
02	Time activ. exit button	00-99" [06]	Relay activation of lock releases from exit button (terminals Bs y -)
03	Panel type	0: Sub-Block [1]: Block 2: General Entrance	Configuration of panel type
04	Block N°	00-99 [00]	Block number belonging to the panel
05	Sub-Block N°	00-99 [00]	Sub-block number belonging to the panel
06	Panel N°	0-9 [0]	Panel number
07	Door sensor time	000-250 [000] inactive	Maximum time that the door is allowed to remain open once activated
08	Opening code	0000-9999 [0000] inactive	Opening code from the keyboard. The means of entering the code: A + XXXX (4 digits)
09	Programming code	0000-9999 [4444]	Code to access programming
10	MASTER panel	[0]: No / 1: Yes	Activation of panel as master to programme home terminals
11	Caretaker Mode	[0]: No Reset 1: Reset	Reset to night mode by entering “1” in this position
12	Monitor Volume	0-9 [5]	Adjust the volume of the panel monitor
13	RESET settings	[0]: No Reset 1: Reset	Return to default settings by entering a “1” in this position
14	Camera focus	0-9 [9]	The selection of different values 0-9, represent each of the video screens to capture.
15	Call digits for general entry	4 ó 6 [6]	Choice of number of digits to call from General Entry
16	Automatic hang-up	[0]: deactivated 1: activated	When activated after opening the door during a conversation, it cuts off the conversation after 5 seconds

Configuration of parameters

Enter the two digits from the position, a “beep” will sound, then enter the chosen value (1, 2, 3 or 4 digits depending on the parameter). If the value is correct, a confirmation tone will sound (beep-beep) and the new value will be saved. If the value is incorrect, the error tone will sound (bop).

Position + Possible values

01...14 (beep) 1, 2, 3 or 4 digits (beep-beep)

Commentary

Digits based on the parameter chosen

Examples

09 (beep) 1128 (beep-beep)

Change of programming code to 1128

01 (beep) 02 (beep-beep)

Change of lock release activation time to 2 seconds

In order to exit the programming, press ‘A’ while entering the menu position number. Programming will also be exited after 60” if no key is pressed, generating a beep-beep tone.

DIGITAL OUTDOOR PANELS

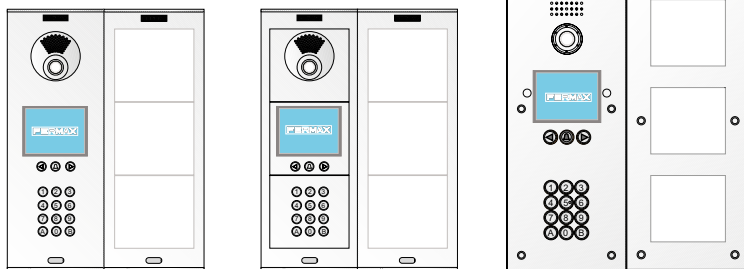

4b) Basic configurations of the extra display

Different parameters can be configured using the display.. In order to do this it is necessary to enter programming mode.

ENTER PROGRAMMING MODE

Press A and enter the access code:
AB21AB

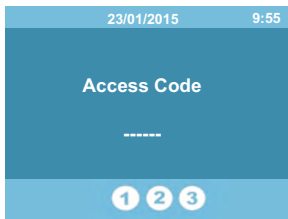

Enter the programming code:
19025 (by default)



If an incorrect code is entered there will be a revert to standby

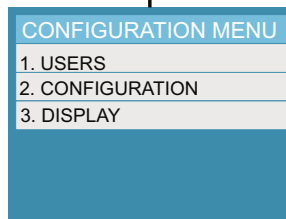

CONFIGURATION MENU.

Main options menu. Use the dialling keypad to choose the option desired. Parameters that may be configured::

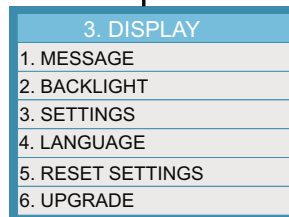
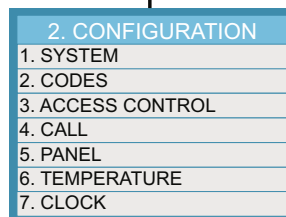
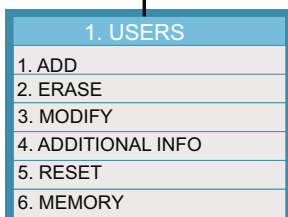

Depending on the **programming code** that has been entered (installer, administrator or concierge code), some of these functions may not appear.

Note: For more information about the display functions see instructions code. 97869 Quick guide to extra display programming, available on the website.

2. CONFIGURATION: This enables the setting of the parameters of the outdoor panel. Use the numeric keypad to select the desired configuration option.

2. CONFIGURATION	
1. SYSTEM	
2. CODES	
3. ACCESS CONTROL	
4. CALL	
5. PANEL	
6. TEMPERATURE	
7. CLOCK	

3. ACCESS CONTROL	
1. DOOR OPEN TIME	
2. HALL TIME	
3. PROX READER	
4. PIN REQUEST	
5. DOOR SENSOR	

3. ACCESS CONTROL.

This option enables the configuration of the parameters relating to the door openings and the access control.

Within each option, use the keypad to enter the data and use B to confirm.

1. DOOR OPENING TIME	
03	
Delete	A
Exit	B

Lock release activation time. Activation of the lock release relay from the apartment or the access control.

Value settings [default] 01-99" [03].

2. HALL TIME	
06	
Delete	A
Exit	B

Hall time.

Activation of the lock release relay from the exit button (terminalsBs and -).

Value settings [default] 00-99" [06].

5. DOOR SENSOR	
--	
Delete	A
Exit	B

Door sensor time.

Maximum time that the door may be open from the door opening.

Value settings [default] 000-250" [000] inactive.

5. PANEL	
1. PANEL NAME	
2. PANEL NUMBER	
3. PANEL TYPE	
4. MASTER	
5. BLOCK	

5. OUTDOOR PANEL.

This option enables the configuration of the parameters relating to the panel.

Within each of the options, use the arrows as selection tools or use the keypad to enter the data and use B to confirm.

1. PANEL NAME	
EDIFICIO SOL----	
Delete	A
Exit	B

2. PANEL NUMBER	
00	
Delete	A
Exit	B

Outdoor panel number.

Value settings [default] 0-9 [0]

3. PANEL TYPE	
Block Entrance	
Exit	B

Configuration of the type of outdoor panel.

- General Entrance:
- Block Entrance (by default).
- Sub-Block Entrance .

4. MASTER	
Disabled	
Exit	B

Activation of the outdoor panel as the master for the programming of apartment terminals.

Once the programming of the monitors/telephones is complete, it is advisable to deactivate the master outdoor panel.

5. BLOCK	
00	
Delete	A
Exit	B

Number of the:

- Block: 00-99 [00]

or

- Sub-Block: 00-99 [00]

(depending on the type of outdoor panel chosen in option3. **TYPE OF OUTDOOR PANEL**, to which the outdoor panel belongs).

Note: The camera focus on the digital outdoor panels will take place in the same way as the direct outdoor panels. Convert the digital outdoor panel into a direct outdoor panel by disconnecting the display and connecting the keypad directly to the amplifier until set. See 3b) Configuration table in direct outdoor panels, (previous pages).

 c) PRE-WIRING

1c) Skyline Outdoor Panels

The DUOX PLUS Skyline outdoor panels form the line of continuous profile outdoor panels with modular composition. Assembling the outdoor panel is very simple. Simply select the combination of modules, fit these in position and connect them using the connection cables.

Note: It is possible to use pushbuttons combined with a keyboard in order to be able to make direct calls to certain apartments (liberal professions), only in digital outdoor panels.

The DUOX PLUS video amplifiers now have a digital microphone integrated into the amplifier module. On DUOX PLUS Video Amplifiers, do not connect the microphone and remove it from the frame.

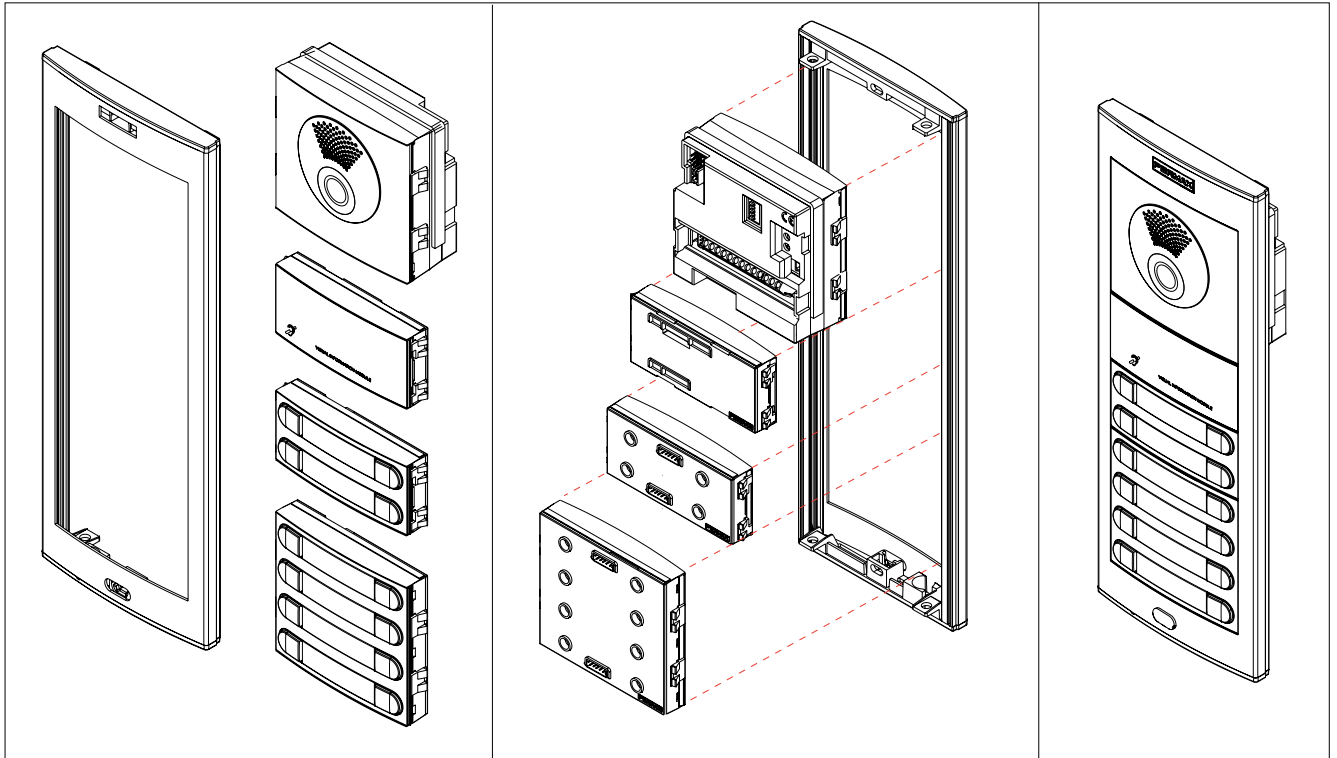

Pre-wiring for PUSHBUTTONS Skyline outdoor panel

The Skyline pushbutton modules do not require call extension modules because these modules include the call code generation feature.

The DUOX amplifier automatically assigns the call codes to the pushbuttons of the connected modules.

The call codes assigned to the pushbuttons can be modified using the mapping function. [See subsection 2.2 Advanced Programming.](#)

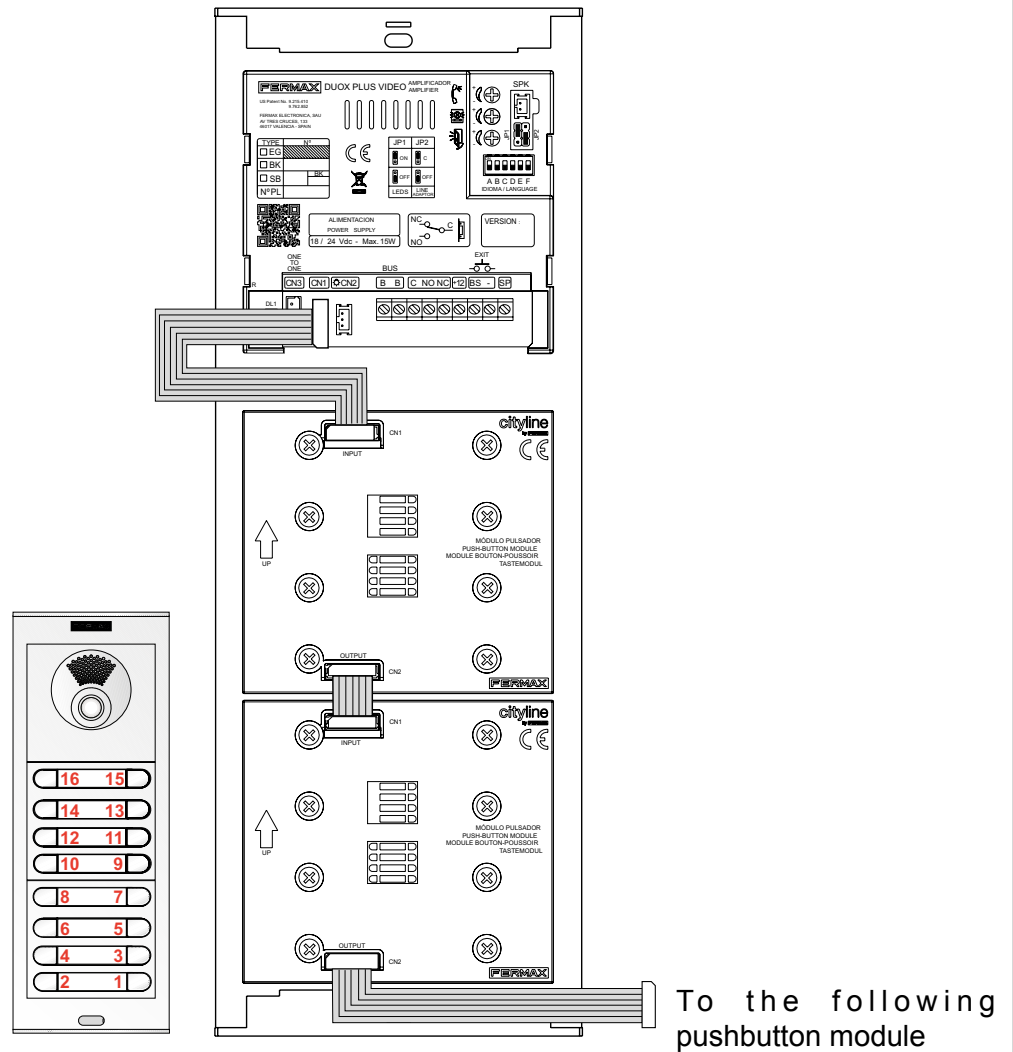

DUOX PLUS addresses assigned by the amplifier

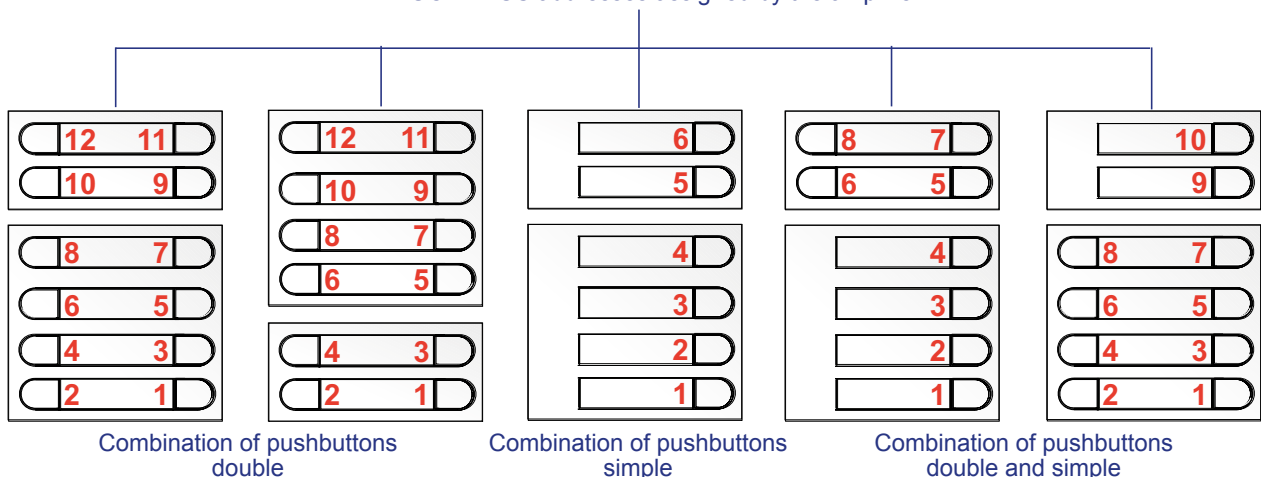

Pre-wiring for DIRECT outdoor panel

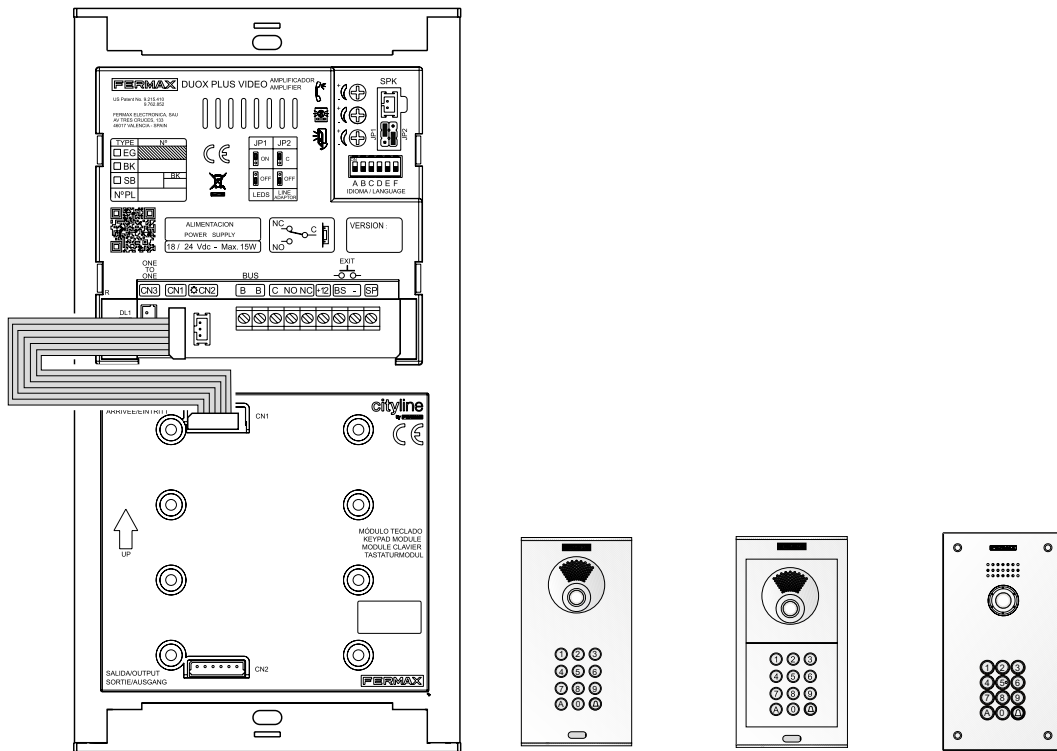

Pre-wiring for DIGITAL outdoor panel

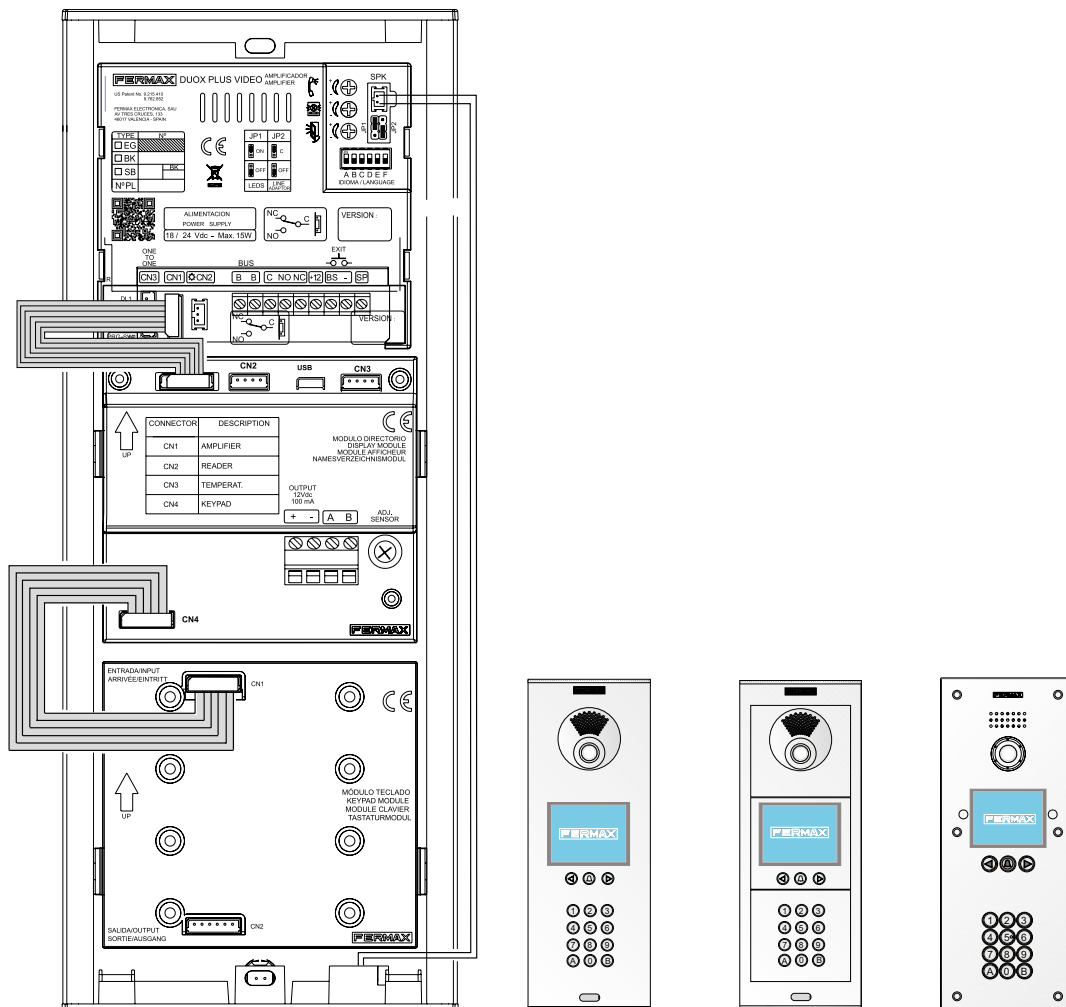

2.1.3 AUDIO AMPLIFIER FOR CITYLINE AND MARINE OUTDOOR PANELS WITH PUSHBUTTONS

a) SETTINGS

1a) Outdoor panel settings

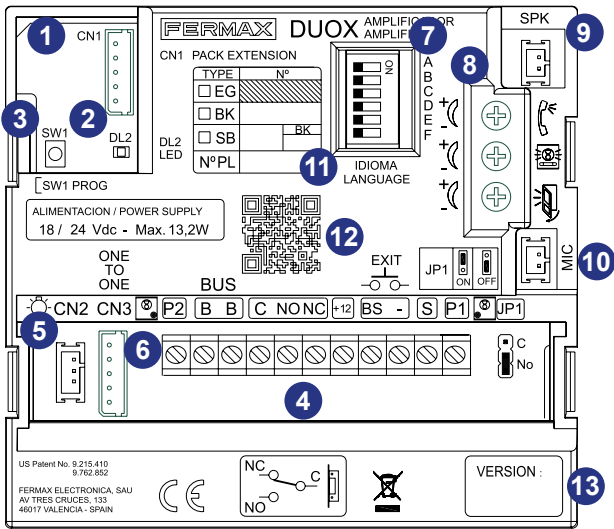

- 1 **CN1 (5 pins)**
Connection call extension module.
- 2 **DL1: Status Led**
Intermittent slow blinking. Inverse or Sequential Programming (mapping of pushbutton panels). Shut down. Standby.
- 3 **SW1 button**
- 4 **Panel Connectors:**
B,B: DUOX Bus: power supply, data, audio and video.
C, NO, NC: Relay dry contact (Max 2A@30Vdc).
+12: output 12 Vdc-250mA (maximum 500mA for 100 seconds).
BS, -: exit button.
S, -: door sensor input.
P1, P2: Integrated button connections.
- 5 **CN2: Individual connection buttons for continuous profile Cityline panel.**
- 6 **CN3: OneToOne Module Connection**
- 7 **Language selection¹**
of the "door open" message.
- 8 **Audio setting**
of the Monitor/Telephone, the outdoor panel and the door open.
- 9 **SPK: Loudspeaker connection**
- 10 **Microphone connection**
- 11 **Programming details label**
- 12 **QR Code**
- 13 **Amplifier version**

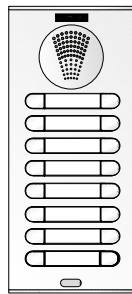
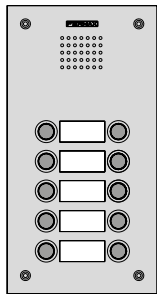

¹Door open' warning language selection

0 Spanish	1 English	2 French	3 Dutch/ Flemish	4 German	5 Catalanian	6 Valencian	7 Balearic	8 Portuguese	9 Basque	10 Galician	11 Greek
12 Polish	13 Czech	14 Slovak	15 Turkish	16 Chinese	17 Persian/ Farsi	18 Arabic	19 Norwegian	20 Finnish	21 Swedish	22 Danish	23 Icelandic
24 Russian	25 Italian	26 Hindi	27 Hungarian	28 Hebrew	29 Croatian	30 French (LONG)	31 bell	31...62 Bell	62 bell	63 DEACTIVATED	

2a) Configuration as master outdoor panel

Required in the event that it is necessary to program the apartment terminal.

Press button SW1 3 times in quick succession. Once 2 seconds have elapsed, a confirmation tone will sound and the master outdoor panel will be activated. Once the programming of the telephones is complete, it is advisable to deactivate the master outdoor panel by **pressing button SW1** 3 times in quick succession.

Note: When an outdoor panel is configured as master, this will advise the rest of the outdoor panels which are connected in the installation and if a different outdoor panel has previously been configured as master, it will then cease to be configured as such.

3a) Outdoor panel coding*

Whenever there is more than one outdoor panel, it will be necessary to program the number of outdoor panels.

4a) Lock release activation time*

Adjusts the door opening time.

Note: Check sub-section 2b) Voice-assisted configuration in pushbutton panels.

5a) Technical specifications of the amplifier

Power supply	18 - 24 Vdc
Standby consumption	1,1W
Active audio consumption	13,2 W
Audio power in the apartment-outdoor panel direction	1 W
Audio power in the outdoor panel-apartment direction	0,15 W
Operating temperature	[-25° , +55°C] / [-13° , 131°F]
Volume adjustable in both directions	

6a) Outdoor panel amplifier parameters

Lock release activation time	01...99 sec. (by default: 03)
Exit button activation time	00...99 sec. (by default: 06) / (deactivated: 00)
Maximum conversation time	90 sec.
Type of outdoor panel	sub-block/block/general entrance. (by default: block)
Block Number	00..99, (by default: 00)
Sub-Block Number	00..99, (by default: 00)
Outdoor Panel Number	0..9, (by default: 0)
Door sensor time	000..250, (by default: 000, non-active)
Volume monitoring	0..9, (by default: 5)
Non-active MASTER outdoor panel	
Mapping	
Sequential programming time of pushbuttons following halt of activity	60 sec.
Inverse programming time of pushbuttons following halt of activity	300 sec.

 b) CONFIGURATION

The DUOX PLUS amplifier includes “Restore” and “Change Value” functions which enable users to restore/change the parameters that have been programmed.

1b) Reset of the mapping of the call code of the pushbuttons

In order to reset the mapping that has been created:

- Remove the power supply.
- Press the SW1 programming button to supply power to the amplifier and hold this button down until the “beep-beep” confirmation signal is heard (5 seconds).

Note: This mapping reset function is for all of the outdoor panels with PUSHBUTTONS regardless of the aesthetic design:

- Cityline outdoor panels
- Marine outdoor panels
- Skyline outdoor panels

2b) Voice-assisted configuration in pushbutton panels

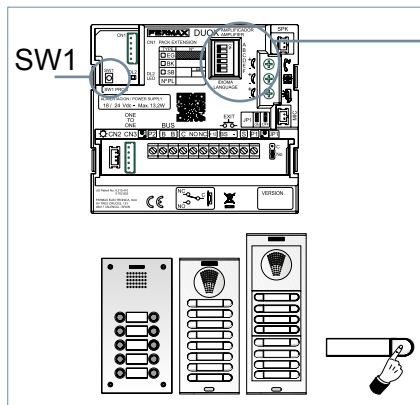

Selection of the language of voice messages by means of the **Synthesiser**. (Languages available: Spanish, English, French, German, Italian and Portuguese).

Note: Voice-assisted configuration is for all of the outdoor panels with PUSHBUTTONS regardless of the aesthetic design:

- Cityline outdoor panels
- Marine outdoor panels
- Skyline outdoor panels

1. Access the configuration by pressing SW1 4 times in a row. The amplifier will reproduce the "CONFIGURATION" message and will initiate the process.

In order to exit the configuration process you may press and hold SW1 for 5 seconds, or the process will be exited automatically if no activity is detected for 30 seconds.

See diagram.

2. Pressing SW1 will move through the different parameters and will reproduce the following by voice: **parameter and current configured value**.

Once the message has been reproduced, pressing on any call button will modify the value (a BEEP will be heard each time the button is pressed and the value will rise).

Once the entry has been completed it is possible to listen to the reproduction of the new value by allowing 5 seconds to elapse without pressing anything. When the value of the parameter reaches the maximum possible value, a BOOP sound will be heard and the value will be situated in the minimum possible of this parameter.

3. Pressing on the call button for 5 seconds will create a BOOP sound and the parameter, when this is the selection of a number, will be located at its minimum value and if it is a type of value it will be reset to the default value.

DIAGRAM

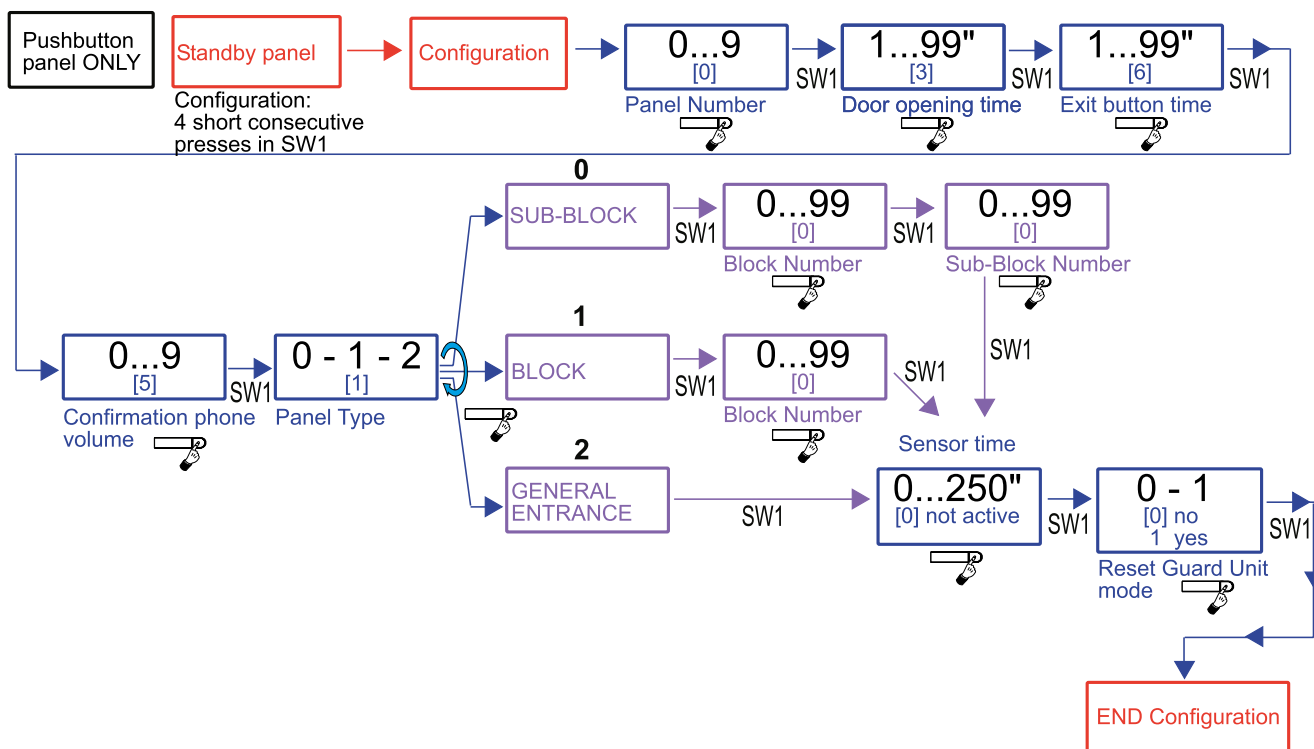

c) PRE-WIRING

1c) Call extension module

One of the benefits of the DUOX PLUS system is the fact that it does not use call wires. This is made possible by the fact that the call is placed through the transmission of a digital code which is generated by the outdoor panel amplifier when a given call button is pressed.

In pushbutton panels (Cityline and Marine), one or more call extension modules are used to generate the specific code for each one of the calls. This module converts the pressing of each button on the outdoor panel into a call code.

The call code that is generated by the pushbutton is determined by the connection from the pushbutton to the call extension module.

There are 2 call extension modules:

- Ref. 2441 16-pushbutton call extension module.
- Ref. 2008 8-pushbutton call extension module.

Cityline kit panels with 1 and 2 pushbuttons

It is only the Cityline kit panels with 1 and 2 pushbuttons that do not require the installation of the call extension module.

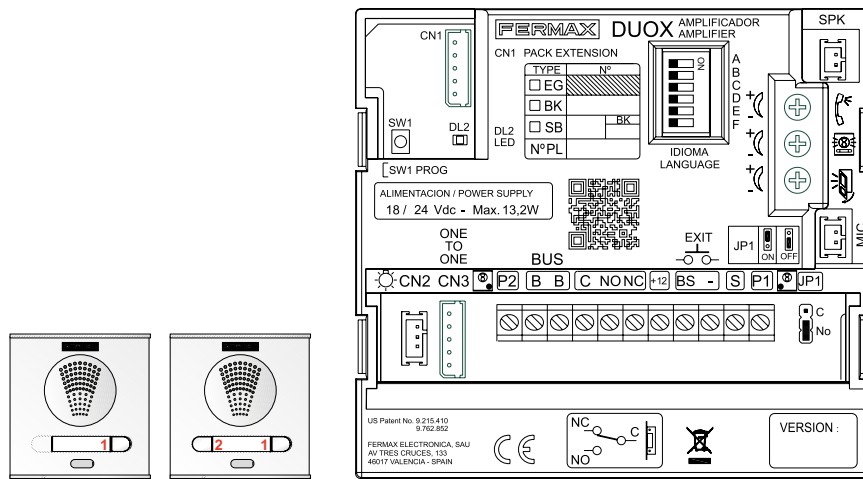

Pre-wiring for Marine kit panels with 1 and 2 pushbuttons with 8-pushbutton call extension module

All of the Marine outdoor panels require the installation of the call extension module, regardless of the number of pushbuttons.

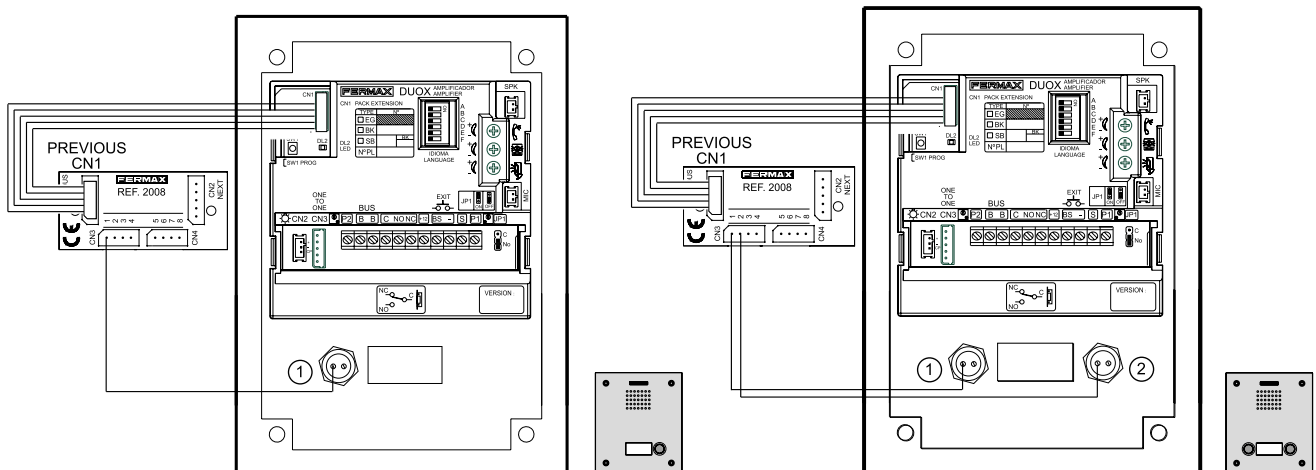

CITYLINE outdoor panel pre-wiring
 Connection of call extension module Ref. 2441.

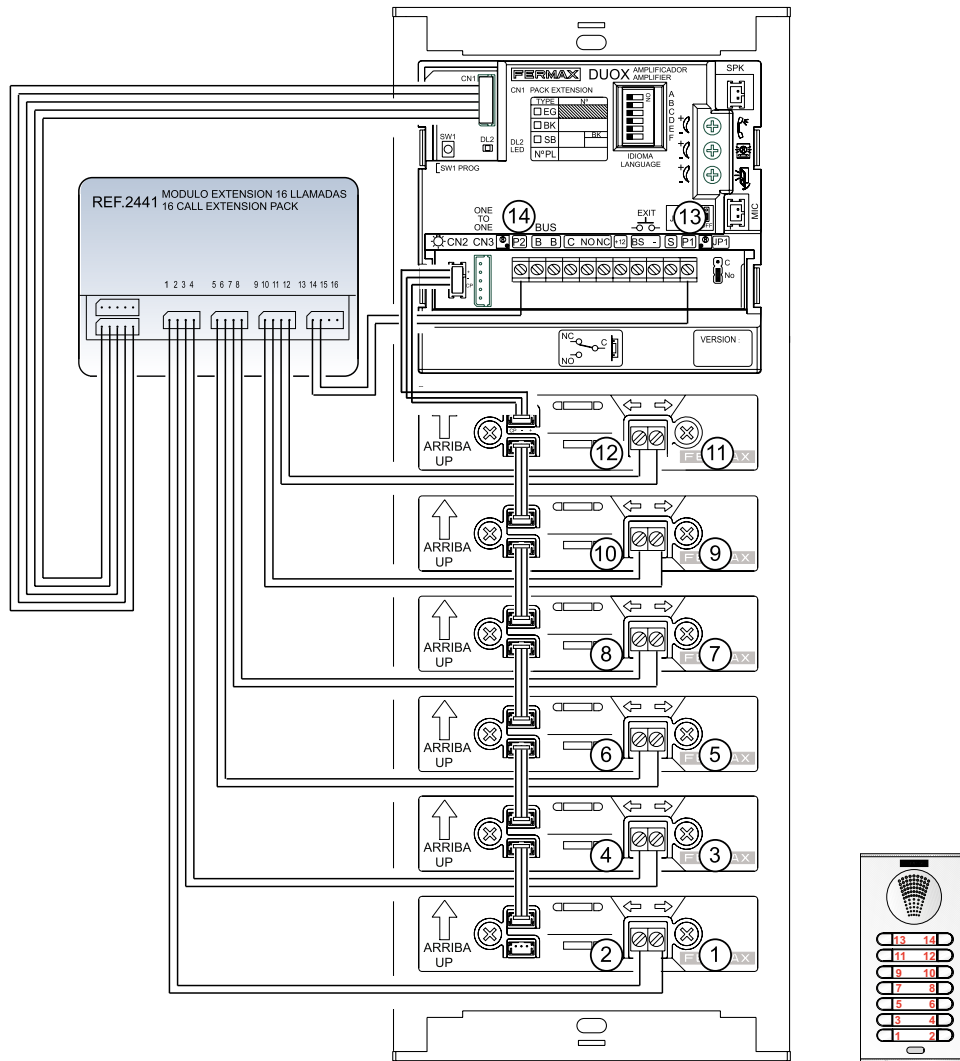

Connection of several call extension modules (more than 16 pushbuttons)

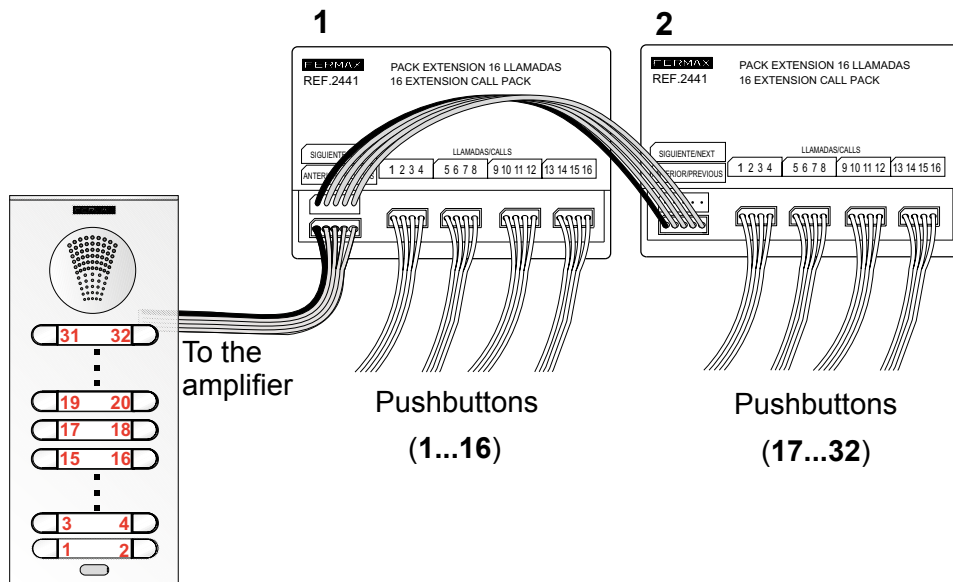

CITYLINE outdoor panel pre-wiring
 Connection of call extension module Ref. 2008.

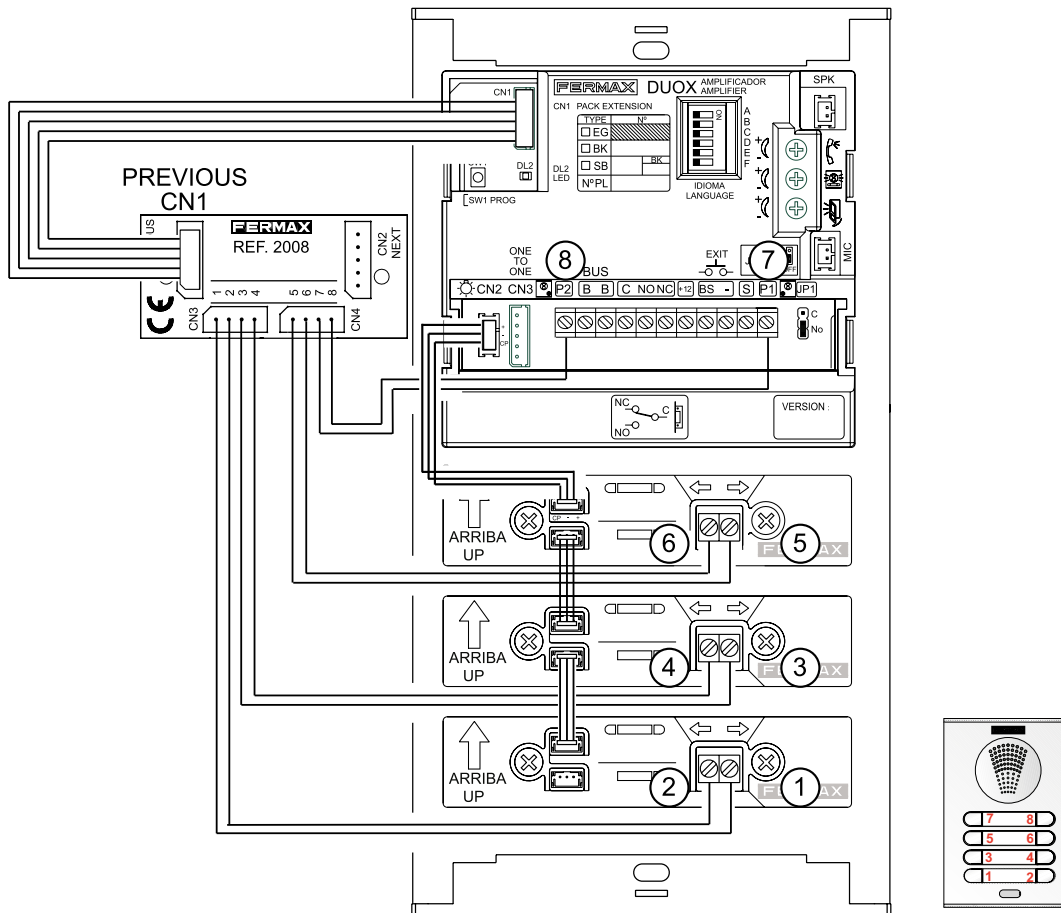

Connection of several call extension modules (more than 8 pushbuttons)

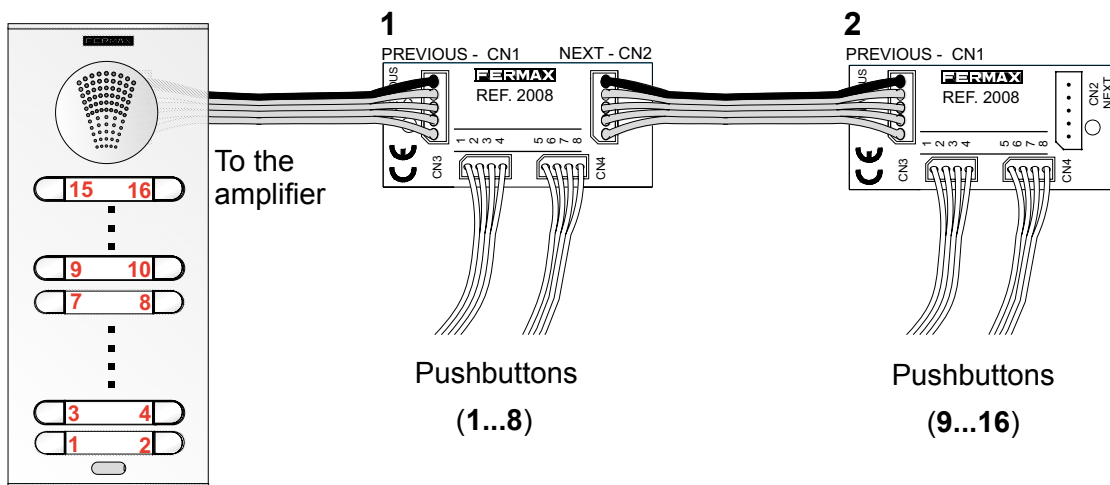

MARINE outdoor panel pre-wiring
 Connection of call extension module Ref. 2441.

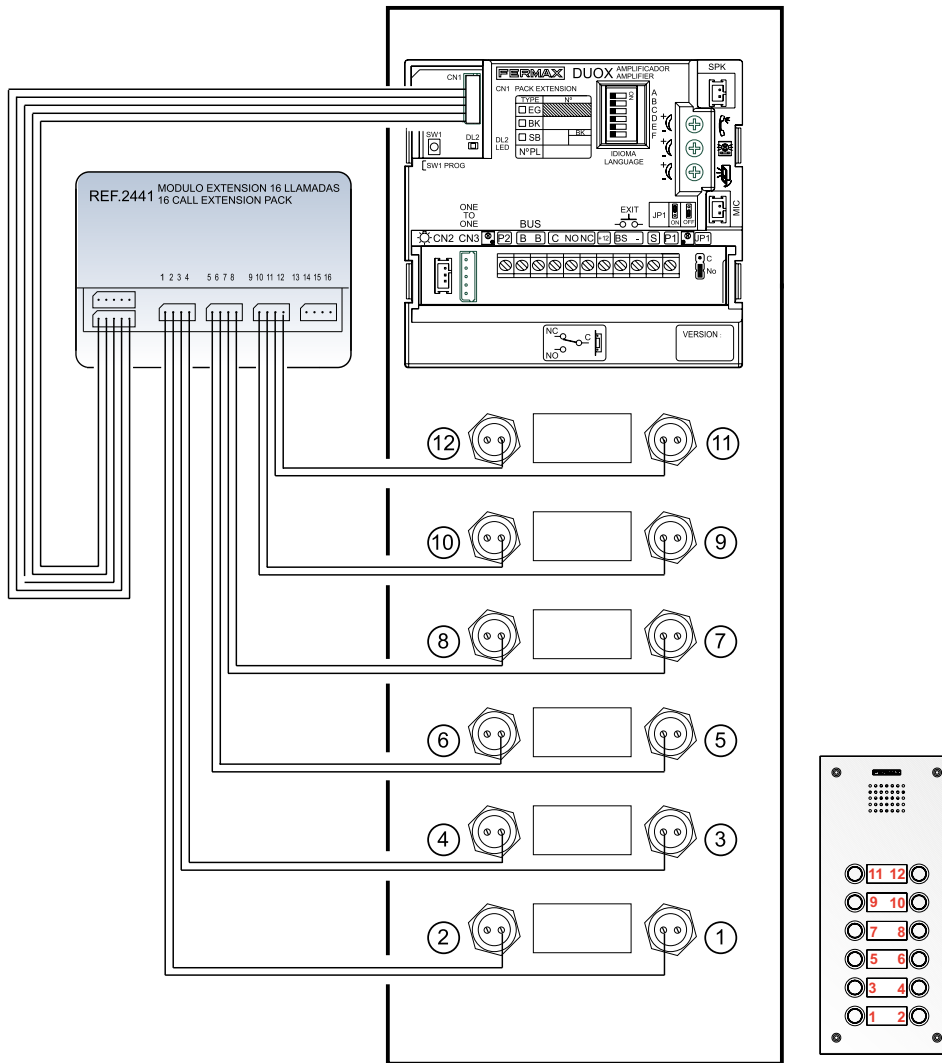

Connection of several call extension modules (more than 16 pushbuttons)

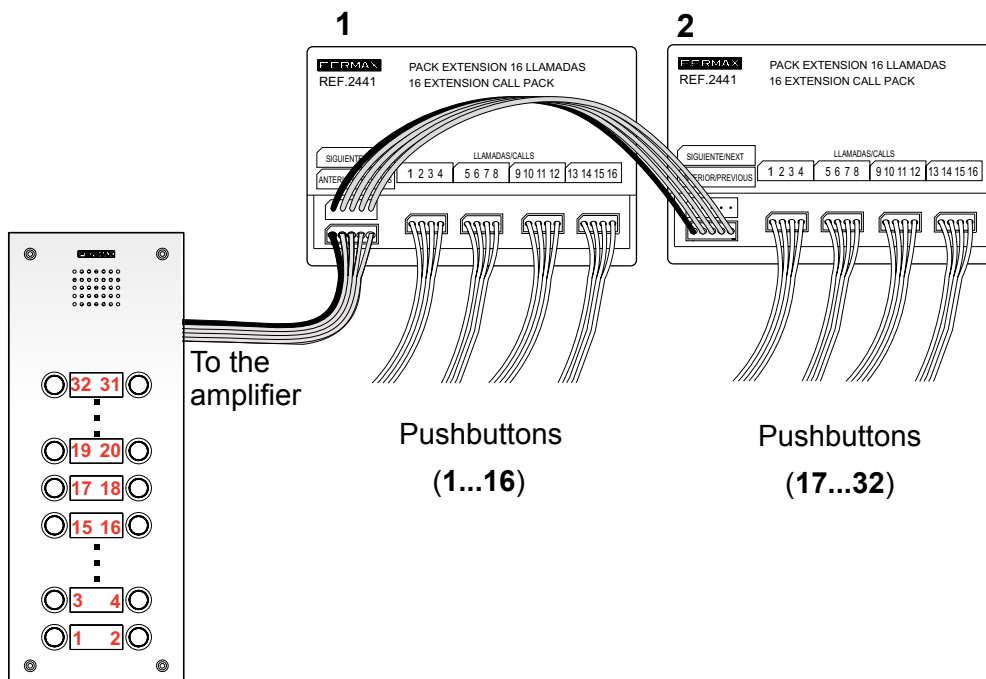

MARINE outdoor panel pre-wiring
 Connection of call extension module Ref. 2008.

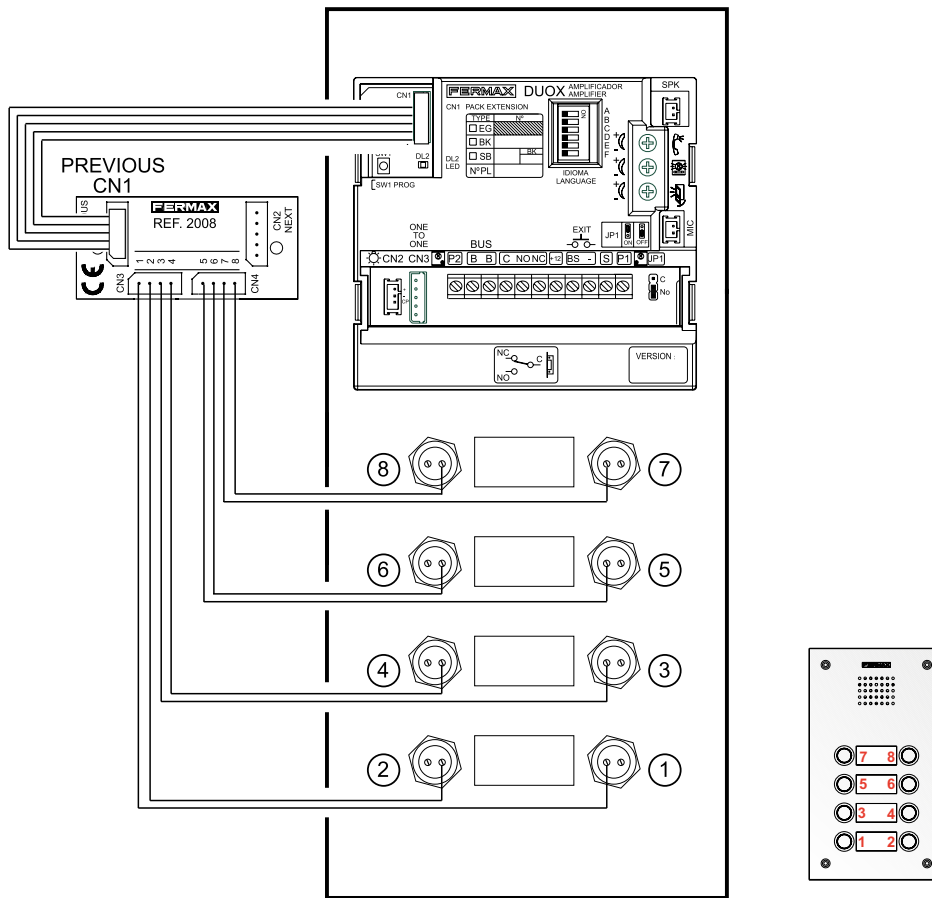

Connection of several call extension modules (more than 8 pushbuttons)

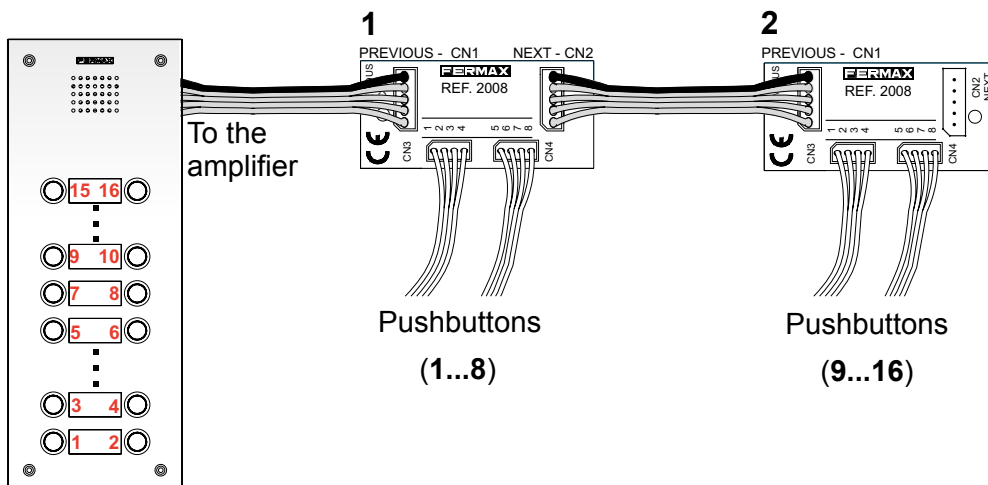

Notes:

- In the event that it is necessary to cover a larger amount of pushbuttons, two or more modules may be used, up to the total of the 99 apartments that enable the DUOX PLUS system in pushbutton panels.
- The assignment of call codes by the call extension module may be modified using the "Mapping" function which is available in the DUOX PLUS amplifier. [See subsection 2.2 Advanced Programming.](#)

2.1.4 AUDIO AMPLIFIER FOR SKYLINE, DIRECT AND DIGITAL OUTDOOR PANELS.

a) SETTINGS

1a) Outdoor panel settings

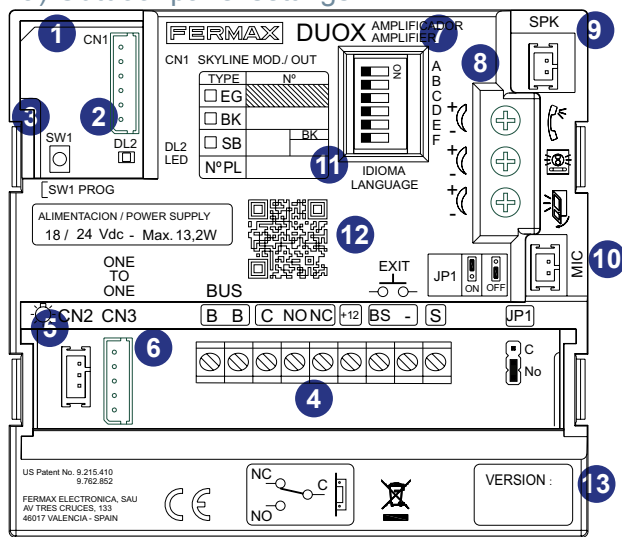

- 1 CN1 (6 pins)**
Connection of modular pushbuttons, keypad and display.
- 2 DL1: Status Led**
Intermittent slow blinking. Inverse or Sequential Programming (mapping of pushbutton panels).
Shut down. Standby.
- 3 SW1 button**
- 4 Panel Connectors:**
B,B: DUOX Bus: power supply, data, audio and video.
C, NO, NC: Relay dry contact (Max 2A@30Vdc).
+12: output 12 Vdc-250mA (maximum 500mA for 100 seconds).
BS, -: exit button.
S, -: door sensor input.
- 5 CN2: Individual connection buttons for continuous profile Cityline panel.**
- 6 CN3: OneToOne Module Connection**
- 7 Language selection¹**
of the "door open" message.
- 8 Audio setting**
of the Monitor/Telephone, the outdoor panel and the door open.
- 9 SPK: Loudspeaker connection**
- 10 Microphone connection**
- 11 Programming details label**
- 12 QR Code**
- 13 Amplifier version**

	DIRECT	DIGITAL	PULSADOR
CITYLINE			
SKYLINE			
MARINE			

¹Door open¹ warning language selection

2a) Configuration as master outdoor panel

- Pushbutton panels:

Required in the event that it is necessary to program the apartment terminal.

Press button SW1 3 times in quick succession. Once 2 seconds have elapsed, a confirmation tone will sound and the master outdoor panel will be activated. Once the programming of the telephones is complete, it is advisable to deactivate the master outdoor panel by **pressing button SW1** 3 times in quick succession.

Note: When an outdoor panel is configured as master, this will advise the rest of the outdoor panels which are connected in the installation and if a different outdoor panel has previously been configured as master, it will then cease to be configured as such.

- Direct outdoor panels: Check **3b) Configuration table in direct outdoor panels (subsequent pages)**.

- Digital outdoor panels: Check **4b) Basic configurations of the extra display (subsequent pages)**.

3a) Outdoor panel coding*

Whenever there is more than one outdoor panel, it will be necessary to program the number of outdoor panels.

4a) Lock release activation time*

Adjusts the door opening time.

*Note: Consult the relevant sub-section for the type of panel in question:

- Pushbutton panel: 2b) Voice-assisted configuration in pushbutton panels (previous pages).
- Direct outdoor panel: 3b) Configuration table in direct outdoor panels (subsequent pages).
- Digital outdoor panel: 4b) Basic configurations of the extra display (subsequent pages).

5a) Technical specifications of the amplifier

Power supply	18 - 24 Vdc
Standby consumption	1,1W
Active audio consumption	13,2 W
Audio power in the apartment-outdoor panel direction	1 W
Audio power in the outdoor panel-apartment direction	0,15 W
Operating temperature	[-25° , +55°C] / [-13° , 131°F]
Volume adjustable in both directions	

6a) Outdoor panel amplifier parameters

Lock release activation time	01...99 sec. (by default: 03)	
Exit button activation time	00...99 sec. (by default: 06) / (deactivated: 00)	
Maximum conversation time	90 sec.	
Type of outdoor panel	sub-block/block/general entrance. (by default: block)	
Block Number	00..99, (by default: 00)	
Sub-Block Number	00..99, (by default: 00)	
Outdoor Panel Number	0..9, (by default: 0)	
Door sensor time	000..250, (by default: 000, non-active)	
Volume monitoring	0..9, (by default: 5)	
Non-active MASTER outdoor panel		
Mapping (pushbutton panel)		
Sequential programming time of pushbuttons following halt of activity	60 sec.	
Inverse programming time of pushbuttons following halt of activity	300 sec.	
Programming code (direct outdoor panel)	0000..9999, (by default: 4444)	
Opening code (direct outdoor panel)	0000..9999, (by default: non-active)	

b) CONFIGURATION

The DUOX PLUS amplifier includes “Restore” and “Change Value” functions which enable users to restore/change the parameters that have been programmed.

SKYLINE PUSHBUTTON PANEL

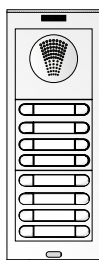

1b) Reset of the mapping of the call code of the pushbuttons

2b) Voice-assisted configuration in pushbutton panels

Note: See chapter 2.1.3 AUDIO AMPLIFIER FOR CITYLINE AND MARINE PANELS WITH PUSHBUTTONS, sub-section b) CONFIGURATION.

DIRECT OUTDOOR PANELS

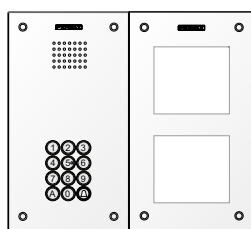
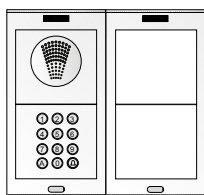
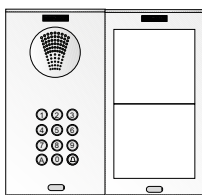

3b) Configuration table in direct outdoor panel

The parameters can be configured using the keypad. In order to do this it is necessary to enter configuration mode using a programming access code after pressing ‘A’.

Entering programming: **A + 4444** (Default programming access code).

If the code is correct, a confirmation tone will sound (beep-beep).

Parameters that may be configured:

Position	Adjust Parameter	Values [default]	Comment
01	Time activ. lock releases	01-99" [03]	Relay activation of lock releases from home or access control.
02	Time activ. exit button	00-99" [06]	Relay activation of lock releases from exit button (terminals Bs y -)
03	Panel type	0: Sub-Block [1]: Block 2: General Entrance	Configuration of panel type
04	Block N°	00-99 [00]	Block number belonging to the panel
05	Sub-Block N°	00-99 [00]	Sub-block number belonging to the panel
06	Panel N°	0-9 [0]	Panel number
07	Door sensor time	000-250 [000] inactive	Maximum time that the door is allowed to remain open once activated
08	Opening code	0000-9999 [0000] inactive	Opening code from the keyboard. The means of entering the code: A + XXXX (4 digits)
09	Programming code	0000-9999 [4444]	Code to access programming
10	MASTER panel	[0]: No / 1: Yes	Activation of panel as master to programme home terminals
11	Caretaker Mode	[0]: No Reset 1: Reset	Reset to night mode by entering "1" in this position
12	Monitor Volume	0-9 [5]	Adjust the volume of the panel monitor
13	RESET settings	[0]: No Reset 1: Reset	Return to default settings by entering a "1" in this position
14	Camera focus	0-9 [9]	The selection of different values 0-9, represent each of the video screens to capture.
15	Call digits for general entry	4 ó 6 [6]	Choice of number of digits to call from General Entry
16	Automatic hang-up	[0]: deactivated 1: activated	When activated after opening the door during a conversation, it cuts off the conversation after 5 seconds

Configuration of parameters

Enter the two digits from the position, a “beep” will sound, then enter the chosen value (1, 2, 3 or 4 digits depending on the parameter). If the value is correct, a confirmation tone will sound (beep-beep) and the new value will be saved. If the value is incorrect, the error tone will sound (bop).

Position + Possible values

01...14 (beep) 1, 2, 3 or 4 digits (beep-beep)

Commentary

Digits based on the parameter chosen

Examples

09 (beep) 1128 (beep-beep)

Change of programming code to 1128

01 (beep) 02 (beep-beep)

Change of lock release activation time to 2 seconds

In order to exit the programming, press ‘A’ while entering the menu position number. Programming will also be exited after 60” if no key is pressed, generating a beep-beep tone.

DIGITAL OUTDOOR PANELS

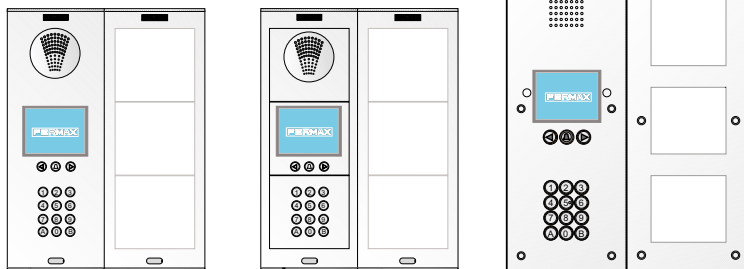

4b) Basic configurations of the extra display

Different parameters can be configured using the display.. In order to do this it is necessary to enter programming mode.

ENTER PROGRAMMING MODE

Press A and enter the access code:
AB21AB



Enter the programming code:
19025 (by default)



If an incorrect code is entered there will be a revert to standby

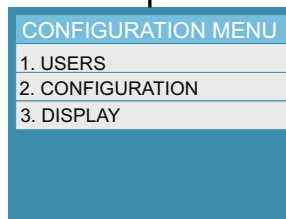

CONFIGURATION MENU.

Main options menu.
Use the dialling keypad to choose the option desired.
Parameters that may be configured::

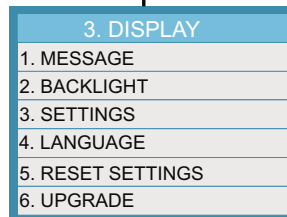
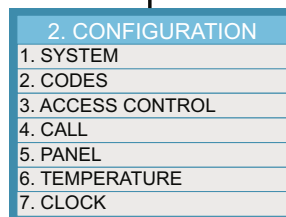
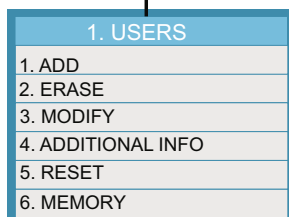

Depending on the **programming code** that has been entered (installer, administrator or concierge code), some of these functions may not appear.

Note: For more information about the display functions see instructions code. 97869 Quick guide to extra display programming, available on the website.

2. CONFIGURATION: This enables the setting of the parameters of the outdoor panel. Use the numeric keypad to select the desired configuration option.

2. CONFIGURATION	
1. SYSTEM	
2. CODES	
3. ACCESS CONTROL	
4. CALL	
5. PANEL	
6. TEMPERATURE	
7. CLOCK	

3. ACCESS CONTROL	
1. DOOR OPEN TIME	
2. HALL TIME	
3. PROX READER	
4. PIN REQUEST	
5. DOOR SENSOR	

3. ACCESS CONTROL.
This option enables the configuration of the parameters relating to the door openings and the access control. Within each option, use the keypad to enter the data and use B to confirm.

1. DOOR OPENING TIME	
03	
Delete	A
Exit	B

Lock release activation time. Activation of the lock release relay from the apartment or the access control.
Value settings [default] 01-99" [03].

2. HALL TIME	
06	
Delete	A
Exit	B

Hall time. Activation of the lock release relay from the exit button (terminalsBs and -).
Value settings [default] 00-99" [06].

5. DOOR SENSOR	
--	
Delete	A
Exit	B

Door sensor time. Maximum time that the door may be open from the door opening.
Value settings [default] 000-250" [000] inactive.

5. PANEL	
1. PANEL NAME	
2. PANEL NUMBER	
3. PANEL TYPE	
4. MASTER	
5. BLOCK	

5. OUTDOOR PANEL.
This option enables the configuration of the parameters relating to the panel. Within each of the options, use the arrows as selection tools or use the keypad to enter the data and use B to confirm.

1. PANEL NAME	
EDIFICIO SOL----	
Delete	A
Exit	B

2. PANEL NUMBER	
00	
Delete	A
Exit	B

Outdoor panel number.
Value settings [default] 0-9 [0]

3. PANEL TYPE	
◀ Block Entrance ▶	
Exit	B

Configuration of the type of outdoor panel.
- General Entrance:
- Block Entrance (by default).
- Sub-Block Entrance .

4. MASTER	
◀ Disabled ▶	
Exit	B

Activation of the outdoor panel as the master for the programming of apartment terminals. Once the programming of the monitors/telephones is complete, it is advisable to deactivate the master outdoor panel.

5. BLOCK	
00	
Delete	A
Exit	B

Number of the:
- Block: 00-99 [00]
or
- Sub-Block: 00-99 [00]
(depending on the type of outdoor panel chosen in option3. **TYPE OF OUTDOOR PANEL**, to which the outdoor panel belongs).

c) PRE-WIRING

1c) Skyline Outdoor Panels

The DUOX PLUS Skyline outdoor panels form the line of continuous profile outdoor panels with modular composition. Assembling the outdoor panel is very simple. Simply select the combination of modules, fit these in position and connect them using the connection cables.

Note: It is possible to use pushbuttons combined with a keyboard in order to be able to make direct calls to certain apartments (liberal professions).

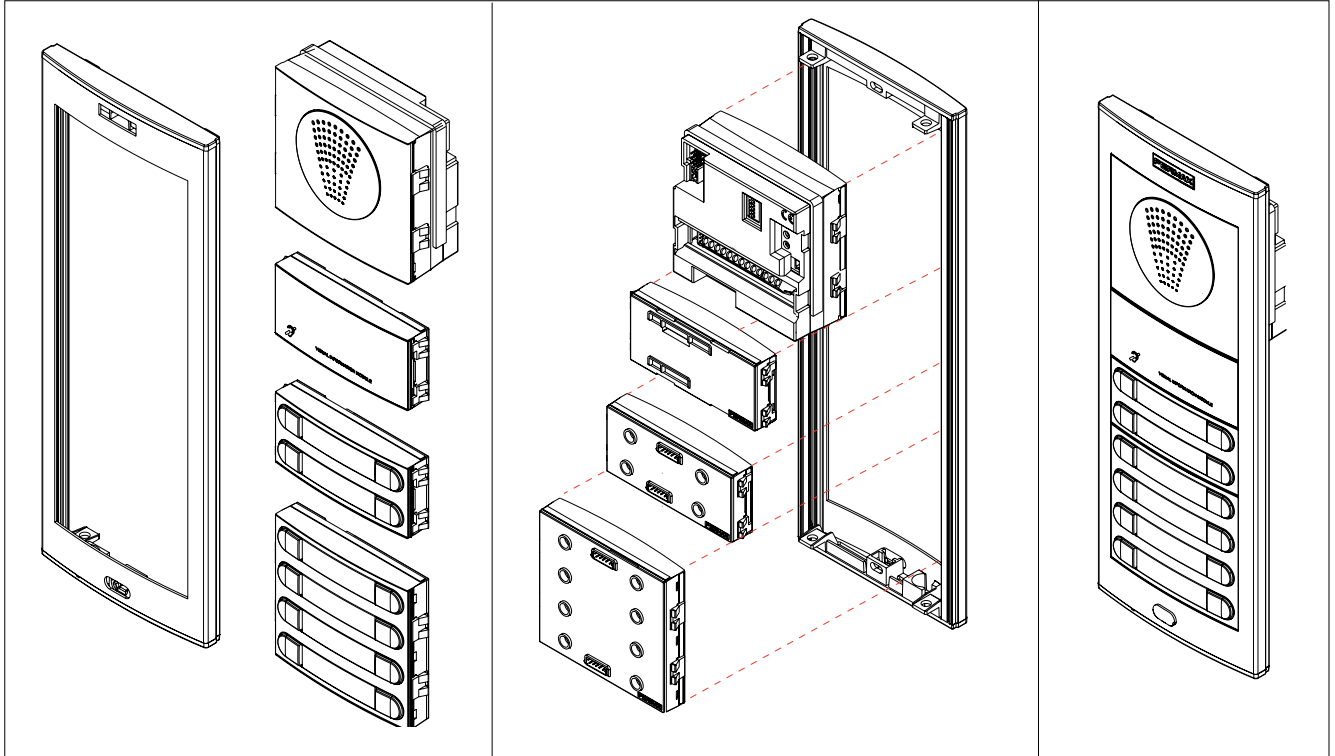

Microphone connection

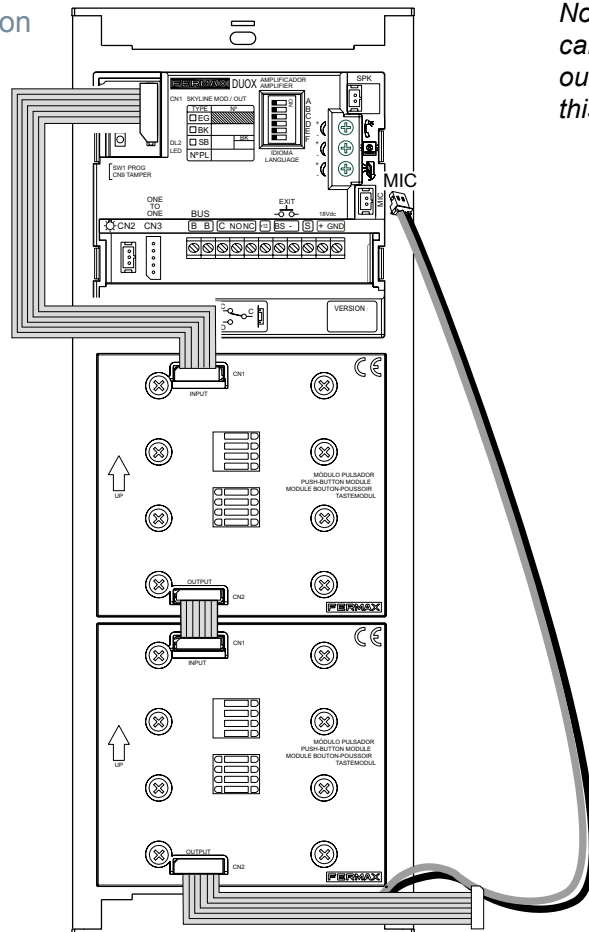

Note: Do not position the microphone cable inserted along the profile of the outdoor panel. We recommend locating this in the module clippings. See detail.

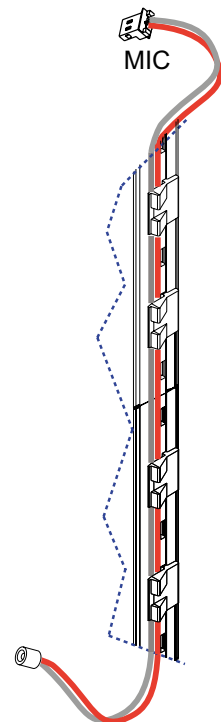

Pre-wiring for PUSHBUTTONS Skyline outdoor panel

The Skyline pushbutton modules do not require call extension modules because these modules include the call code generation feature.

The DUOX PLUS amplifier automatically assigns the call codes to the pushbuttons of the connected modules.

The call codes assigned to the pushbuttons can be modified using the mapping function. [See subsection 2.2 Advanced Programming.](#)

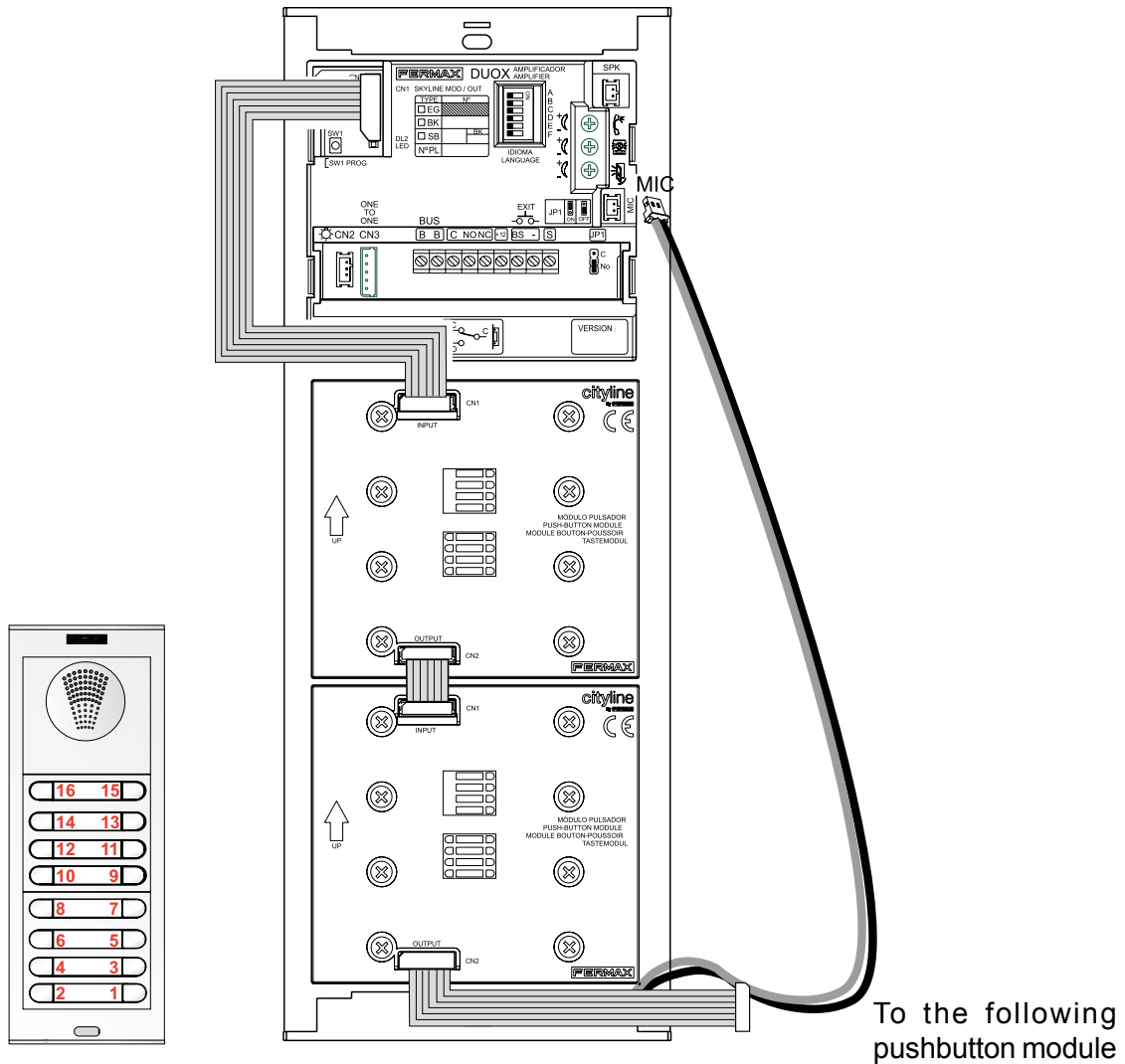

DUOX PLUS addresses assigned by the amplifier

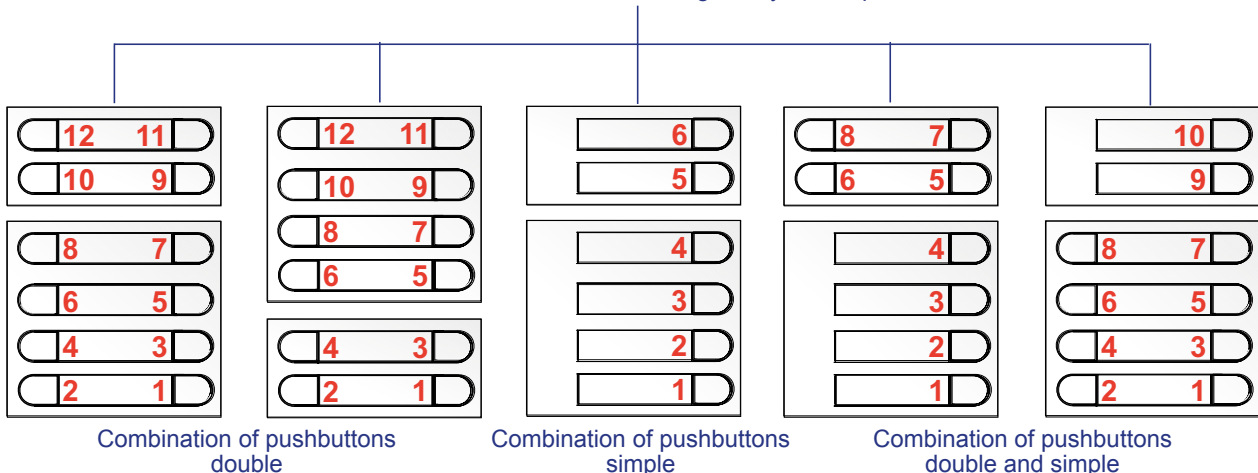

Pre-wiring for DIRECT outdoor panel

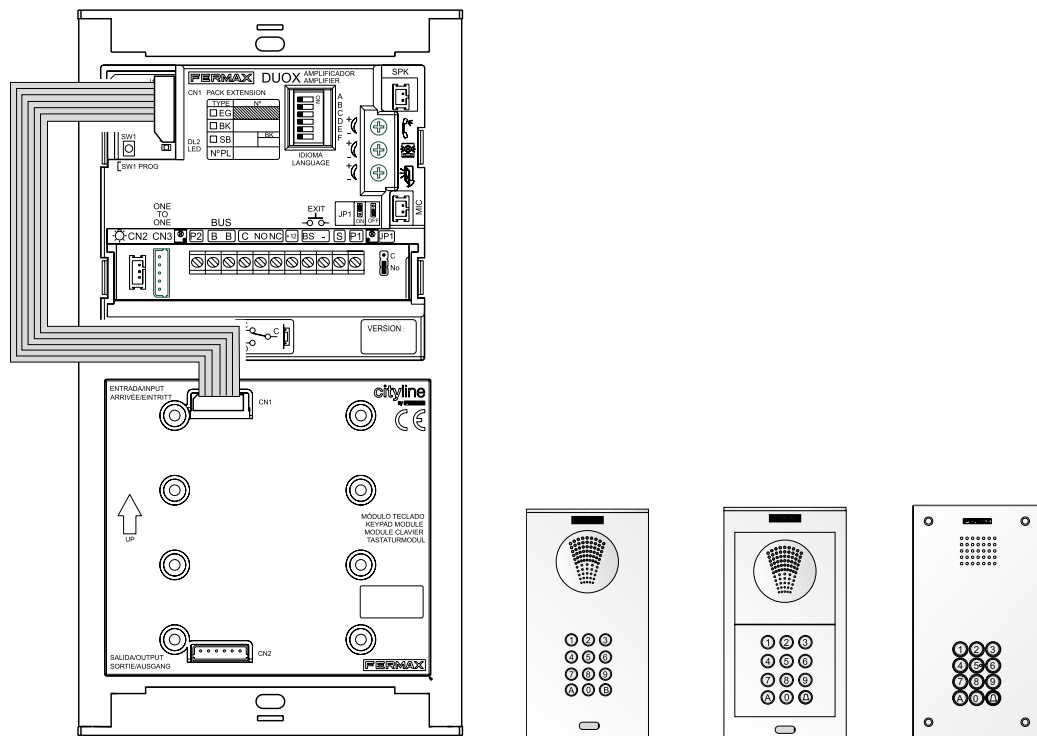

Pre-wiring for DIGITAL outdoor panel

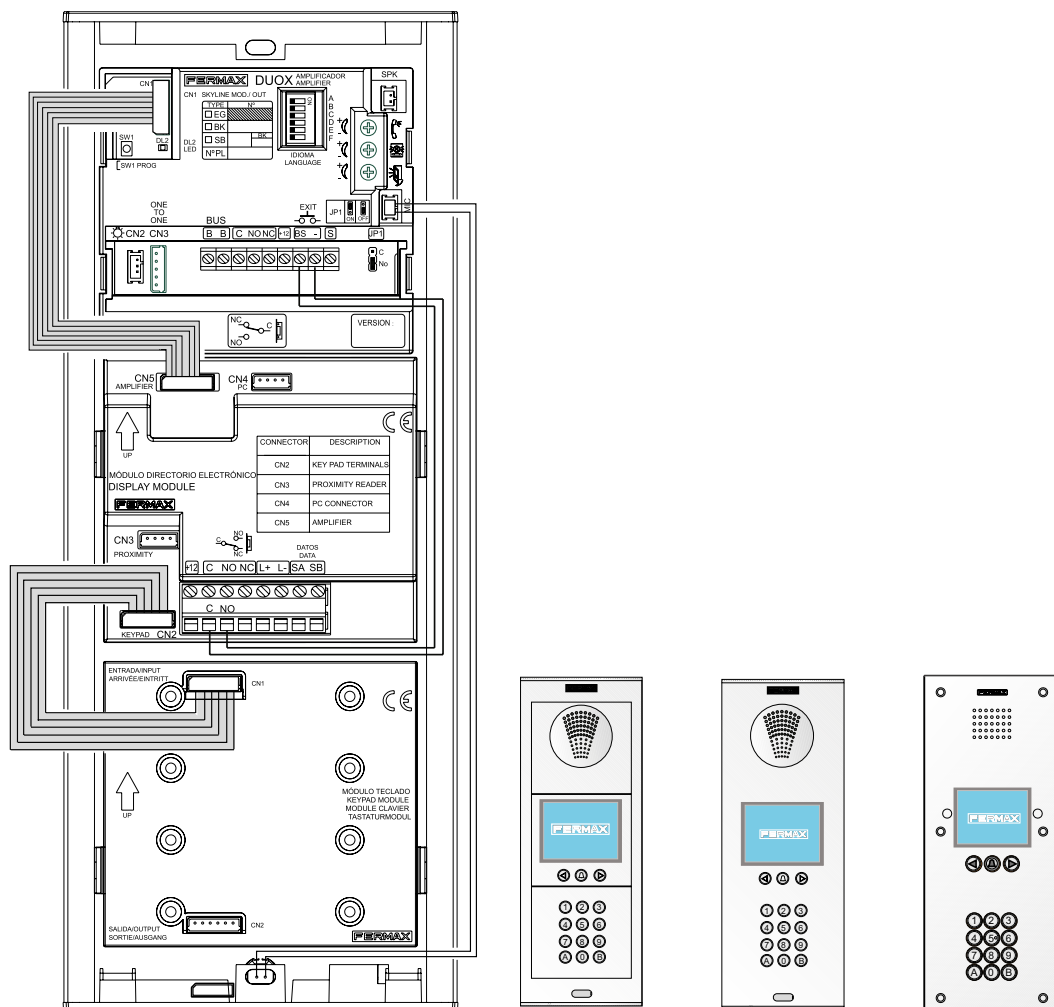

2.2 ADVANCED PROGRAMMING

2.2.1 MAPPING IN PUSHBUTTON PANELS

The call code generated by a pushbutton of a pushbutton panel is determined by:

- Integrated pushbuttons in the “amplifier” of Cityline 1- or 2-line outdoor panels.
- The connection to the “call extension module”:
 - in Cityline outdoor panels with more than 2 pushbuttons and
 - in all of the Marine outdoor panels with pushbuttons
- The interconnection of the “pushbutton module” in Skyline modular outdoor panels.

Mapping is an advanced programming function which is available in the pushbutton panels. Mapping enables users to modify the call code that is assigned to pushbuttons:

- “naturally”, by the position in a call extension module
or
- sequentially, per pushbutton module (from bottom to top and from right to left).

Mapping makes it possible to cover all eventualities in the coding of pushbuttons:

Standard assignment

Depends on the wiring of the call extension module.

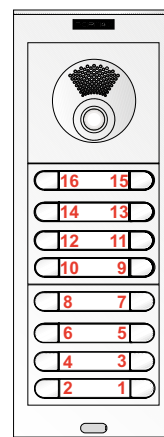
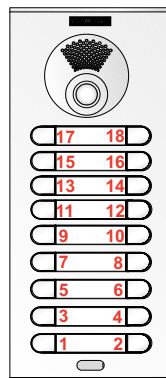

Pushbutton module: sequential, from bottom to top and from right to left.

Mapping

Examples of possible assignments using the mapping function:

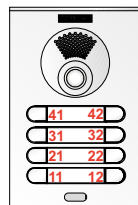

Floor/Apartment
Very useful in installations with a general entrance

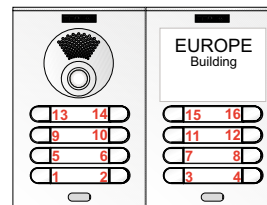

Includes double panel: call assignment per floor based on the distribution of apartments.

There are 2 mapping methods:

1. Inverse Programming.

In the event that it is necessary for the pushbuttons to generate non-consecutive call codes as is the case for codes which include a floor number and an apartment number.

2. Sequential Programming.

In the event that a special distribution is required. On the outdoor panel(s), press the call buttons in the order in which the codes are to be assigned, beginning with 0 (video amplifier)/ beginning with 1 (audio amplifier) and continuing in consecutive order until reaching the final one. *Check the examples in the Notes in subsequent pages.*

Notes:

- Programming is always performed using the activated outdoor panel as the master. Press button SW1 3 times in quick succession. Once 2 seconds have elapsed, a confirmation tone will sound and the panel will be activated as the master. Once the programming is complete, it is advisable to deactivate the master outdoor panel by pressing button SW1 3 times in quick succession.
- To enter in any of the pushbutton mapping modes the amplifier must be in standby mode.

VIDEO Amplifier

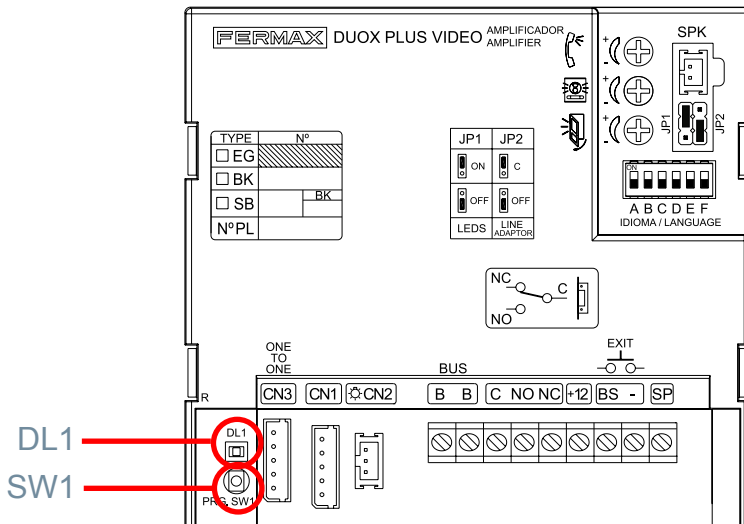

INVERSE PROGRAMMING.

2 operators are required.

This mode enables the assignment of non-consecutive call codes (addresses).

The steps to be taken are as follows:

1. The outdoor panel should first be configured as the master outdoor panel (*see note on previous page*).
2. Programme the monitor locally and independently using an outdoor panel, a guard unit or from the monitor itself. *See subsection 7. Apartment Terminals.*
3. Enter the “inverse pushbutton programming” mode of the amplifier.
Hold down button SW1 for 10 seconds until you hear a “beep” noise. Release button SW1. The Mode LED (DL1) is activated to indicate entry into inverse programming mode (intermittent slow: 1 blink/second slow).
4. Assign the new addresses to each pushbutton:
 - 4.1 Enter the programming mode of the apartment terminal. An enter programming mode tone will sound. Picking up, a conversation will begin with the master outdoor panel to indicate the pushbutton of the apartment to be programmed.
 - 4.2. Hang up the monitor, press the outdoor panel, the call button associated with this apartment.
This pushbutton will be assigned the call code that has previously been programmed in the monitor (store in the amplifier).

Repeat step 4 with all of the apartment terminals-pushbuttons in the installation.

Note: If a pushbutton is pressed in inverse programming without monitor programming having been entered, the amplifier will emit a “bop” error tone.

5. Exit programming:

Press the pushbutton of amplifier SW1 again.

The amplifier will automatically exit programming after 5 minutes of inactivity.

Notes:

- Depending on the range of call codes it will be necessary to configure the outdoor panel (amplifier) accordingly. If all of the monitors:
 - Have the same block and sub-block address (BBSSNN) the outdoor panel will be configured as a sub-block (or block) outdoor panel with these values.
 - Only have the block address in common, the outdoor panel will be configured as a block outdoor panel.
 - Have different block numbers the outdoor panel will be configured as a general entrance.
- Configuration - Amplifier Programming: The DUOX PLUS amplifier may be configured to enable operation as a general entrance outdoor panel, a block entrance outdoor panel or a sub-block entrance outdoor panel. *See chapter 1. INTRODUCTION - 1.5 Call coding.*

SEQUENTIAL PROGRAMMING.

Only 1 operator is required.

This mode enables the sequential assignment of call codes (directions) in the order desired.

The steps to be taken are as follows:

1. The outdoor panel should first be configured as the master outdoor panel (*see note on previous page*).

2. Enter the “sequential pushbutton programming” mode of the amplifier.

Hold down the SW1 button for 10 seconds until a “beep” sounds and keep it held down for a further 5 seconds (a double “beep” will sound). On releasing the button, the Mode LED (DL1) will be activated to indicate that we have entered sequential programming mode (intermittent slow: 1 blink/second fast).

3. Assign the new addresses to each pushbutton:

On the outdoor panel, press the call button in the order in which you wish to associate the codes, starting with 0 and working sequentially until reaching the last one.

- 1st Push = Code 0 (BBSS00). *See Notes.*

- 2nd Push = Code 1 (BBSS01).

- 3rd Push = Code 2 (BBSS02).

- and so on and so forth.

The amplifier will store the new call codes of each pushbutton.

4. Exit programming:

Press the SW1 amplifier “pushbutton programming” pushbutton again.

The amplifier will automatically exit programming after 5 minutes of inactivity.

Notes:

- *If you wish to programme the buttons without starting from the number 0 or to suddenly alter the number from which you wish to continue programming, press the pushbutton to be configured repeatedly until reaching the value of the calculation that you wish to assign.*

• **For example:** *if you wish to assign the values 1, 5 and 10 to three pushbuttons on an outdoor panel, press the first button twice, the second button 4 times and the third button 5 times.*

- *You may configure a pushbutton with Code 0 to make a call to the Guard Unit (if applicable).*

- *Depending on the range of call codes it will be necessary to configure the outdoor panel (amplifier) accordingly.*

RESET mapping in pushbutton panels

In order to reset the mapping that has been made:

- Remove the power supply.

- Press the SW1 programming button to supply power to the amplifier and hold this button down for 5 seconds. You should hear a “beep” sound. The LED (DL1) will blink rapidly to indicate that the restore process has taken place.

AUDIO Amplifier

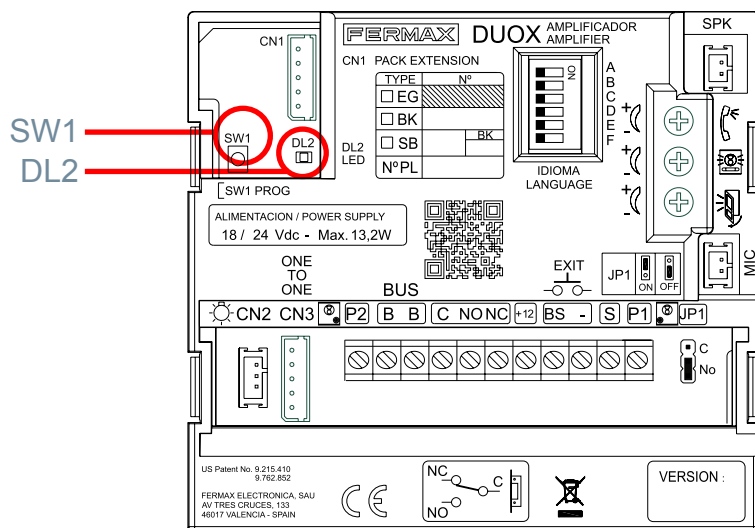

INVERSE PROGRAMMING.

2 operators are required.

This mode enables the assignment of non-consecutive call codes (addresses).

The steps to be taken are as follows:

1. The outdoor panel should first be configured as the master outdoor panel (*see note on previous page*).
2. Programme the telephone locally and independently using an outdoor panel or guard unit. *See subsection 7. Apartment Terminals.*
3. Enter the “inverse pushbutton programming” mode of the amplifier.

Hold down the SW1 button for 10 seconds until you hear a “beep” noise. Release button SW1. The Mode Led (DL2) is activated to indicate that we have entered inverse programming mode (intermittent slow: 1 blink/second slow).

4. Assign the new addresses to each pushbutton:

4.1 Enter the programming mode of the apartment terminal. An enter programming mode tone will sound. Picking up, a conversation will begin with the master outdoor panel to indicate the pushbutton of the apartment to be programmed.

4.2 Hang up the telephone and press the outdoor panel, the call button associated with this apartment. This pushbutton will be assigned the call code that has previously been programmed in the monitor (stored in the amplifier).

Repeat step 4 with all of the apartment terminals-pushbuttons in the installation.

5. Exit programming:

Press the pushbutton of amplifier SW1 again.

The amplifier will automatically exit programming after 5 minutes of inactivity.

Notes:

- Depending on the range of call codes it will be necessary to configure the outdoor panel (amplifier) accordingly. If all of the telephones:
 - Have the same block and sub-block address (BBSSNN) the outdoor panel will be configured as a sub-block (or block) outdoor panel with these values.
 - Only have the block address in common, the outdoor panel will be configured as a block outdoor panel.
 - Have different clock numbers the outdoor panel will be configured as a general entrance.
- Configuration - Amplifier Programming: The DUOX PLUS amplifier may be configured to enable operation as a general entrance outdoor panel, a block entrance outdoor panel or a sub-block entrance outdoor panel. *See chapter 1. INTRODUCTION - 1.5 Call coding.*

SEQUENTIAL PROGRAMMING.

Only 1 operator is required.

This mode enables the sequential assignment of call codes (directions) in the order desired.

The steps to be taken are as follows:

1. The outdoor panel should first be configured as the master outdoor panel (*see note on previous page*).

2. Enter the “sequential pushbutton programming” mode of the amplifier.

Hold down the SW1 button for 10 seconds until a “beep” sounds and keep it held down for a further 5 seconds (a double “beep” will sound). On releasing the button, the Mode LED (DL2) will be activated to indicate that we have entered sequential programming mode (intermittent slow: 1 blink/second fast).

3. Assign the new addresses to each pushbutton:

On the outdoor panel, press the call button in the order in which you wish to associate the codes, starting with 1 and working sequentially until reaching the last one.

- 1st Push = Code 1 (BBSS01).
- 2nd Push = Code 2 (BBSS02).
- 3rd Push = Code 3 (BBSS03).
- and so on and so forth.

The amplifier will store the new call codes of each pushbutton.

4. Exit programming:

Press the SW1 amplifier “pushbutton programming” pushbutton again.

The amplifier will automatically exit programming after 5 minutes of inactivity.

Notes:

- *If you wish to programme the buttons without starting from the number 1 or to suddenly alter the number from which you wish to continue programming, press the pushbutton to be configured repeatedly until reaching the value of the calculation that you wish to assign.*
- **For example:** *if you wish to assign the values 1, 5 and 10 to three pushbuttons on one outdoor panel, press the first button once, the second button 4 times and the third button 5 times.*
- *Depending on the range of call codes it will be necessary to configure the outdoor panel (amplifier) accordingly.*

RESET mapping in pushbutton panels

In order to reset the mapping that has been made:

- Remove the power supply.
- Press the SW1 programming button to supply power to the amplifier and hold this button down until the “beep-beep” confirmation signal is heard (5 seconds).

2.2.2 MAPPING IN DIGITAL OUTDOOR PANELS

Mapping is an advanced programming option which is also available in digital outdoor panels. Mapping enables the modification of the call code that has been inherently assigned by the system for another different call code in order to cover all of the coding requirements.

In these outdoor panels call coding can be effectuated using any character (letters and numbers) up to a maximum of 6.

Mapping can be effectuated from the outdoor panel (keypad + display) or using the extra display software. The Display Plus software is a PC-based application which serves to exchange data with the FERMAX EXTRA DISPLAY unit.

This exchange of data makes it possible to perform different operations with the display, meaning that the Display Plus software can be considered as a tool which enables the installer to perform certain tasks that would be more cumbersome if they were to be performed through the keypad of the outdoor panel in which the display is installed.

Notes:

- For more information about the display functions see instructions code. 97869 Quick guide to extra display programming, available on the website.
- Both the software application and the manual code. 97830 Manual software display extra, are available on our webpage.

Mapping from the keypad + display in digital outdoor panels

- a) Enter programming mode.
- b) Enable the alphanumeric keypad (in order to be able to write user names).
- c) Add users.
- d) Enable mapped calling.

a) ENTER PROGRAMMING MODE

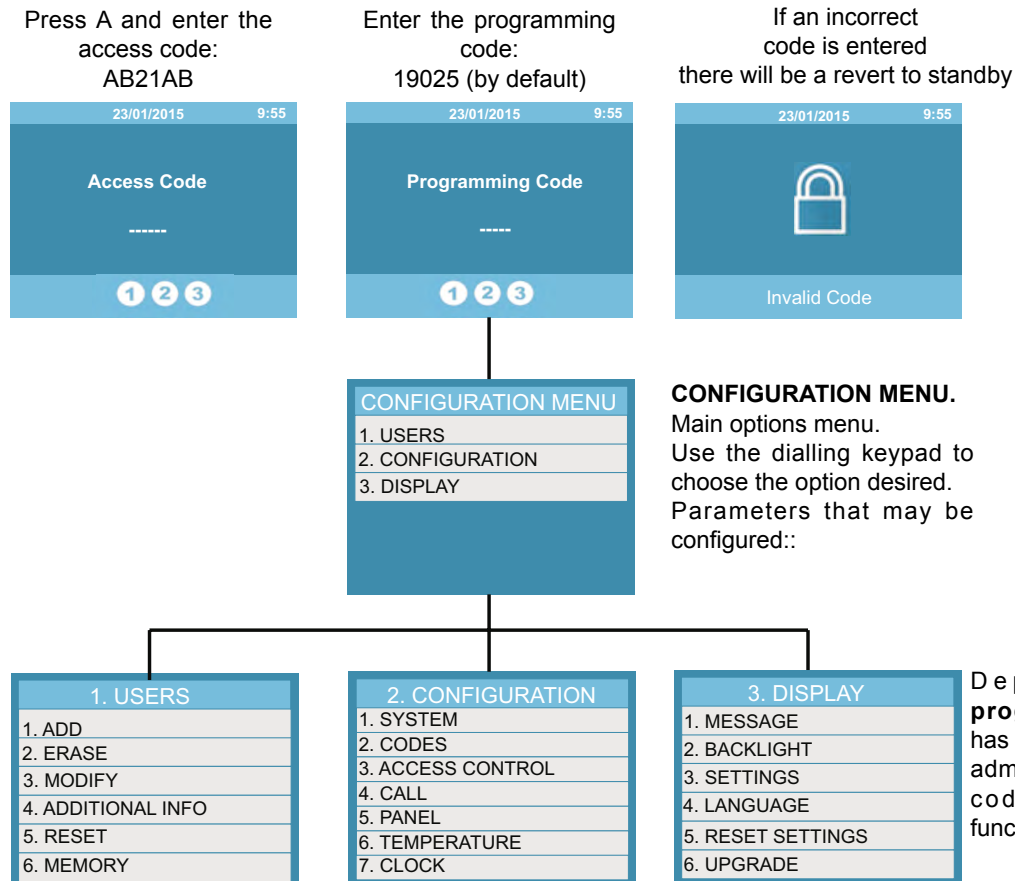

b) ENABLE ALPHANUMERIC KEYPAD (in order to be able to write user names)

3. DISPLAY: Enables the performance of settings relating to information from the display. Use the numeric keypad to select the desired configuration option.

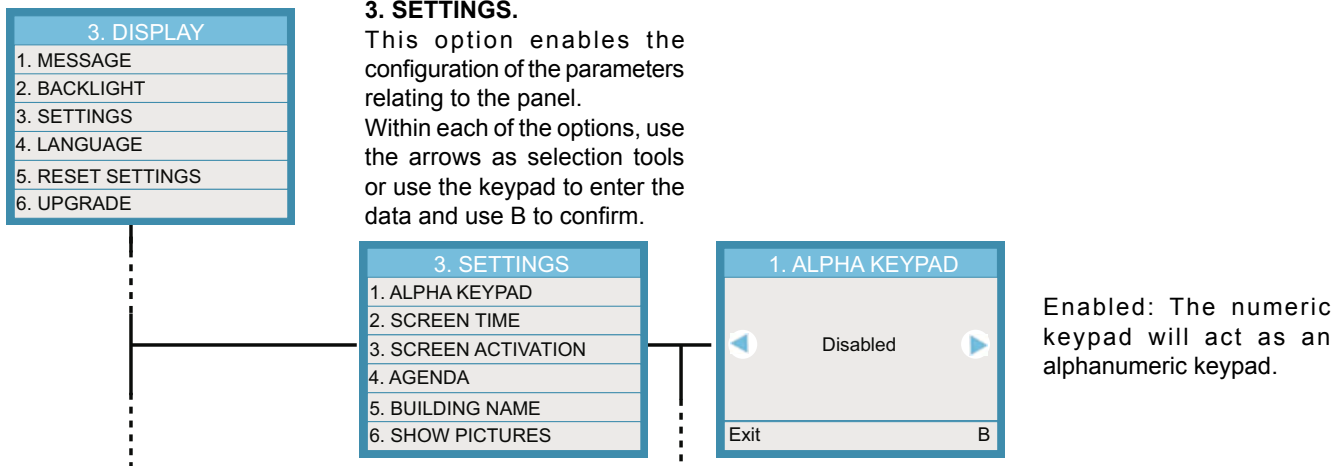

c) ADD USERS

1. USERS: Enables the configuration of the data of different users.

1. Add: Use the arrows to scroll through the different menus. Pressing B from any sub-menu saves the data and reverts to the USER menu.

- Apartment is the unmapped call.
- Call code is the mapped call.

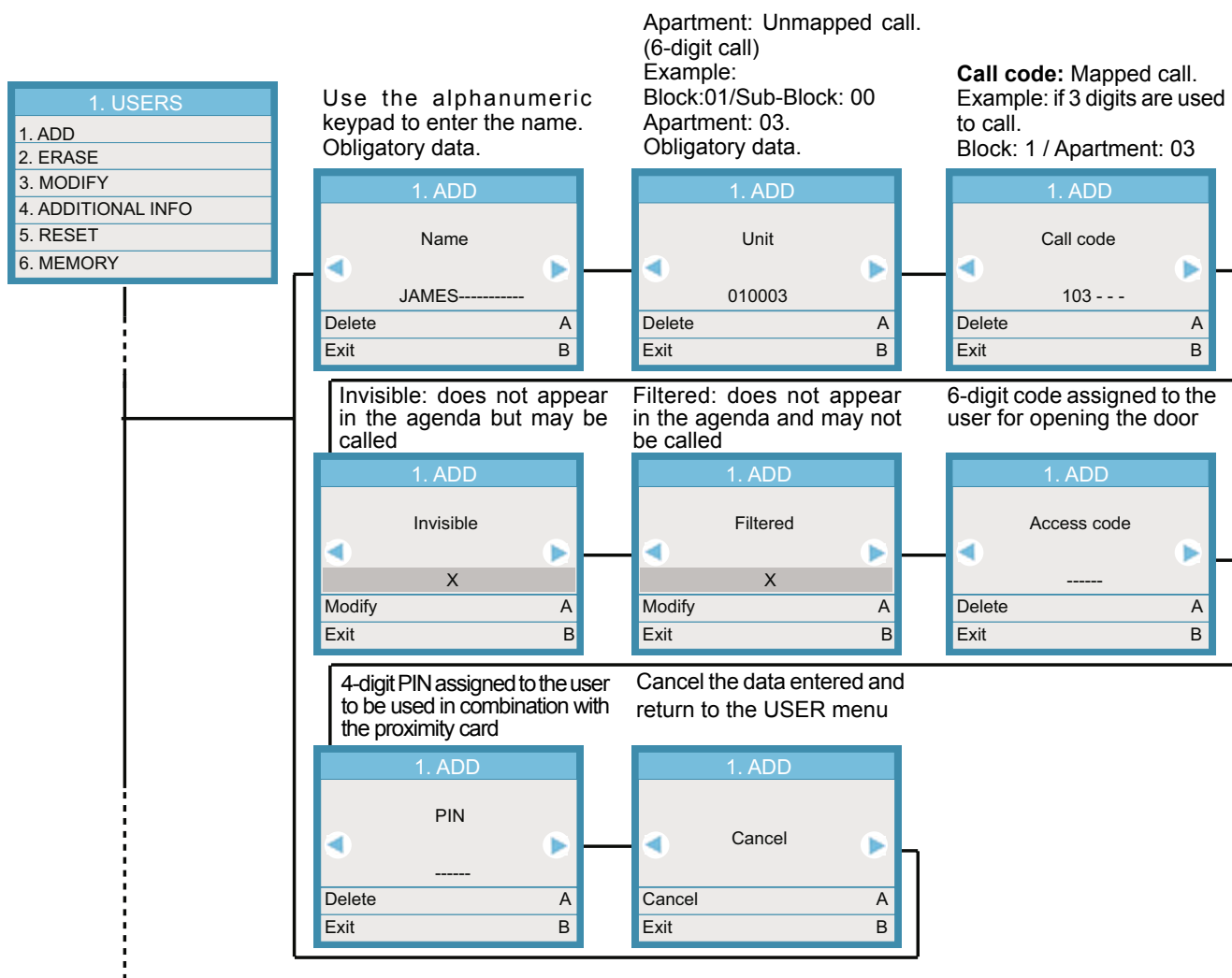

d) ENABLE MAPPED CALLING

2. CONFIGURATION: This enables the setting of the parameters of the outdoor panels. Use the numeric keypad to select the desired configuration option.

2. CONFIGURATION
1. SYSTEM
2. CODES
3. ACCESS CONTROL
4. CALL
5. PANEL
6. TEMPERATURE
7. CLOCK

4. CALLING.

This option makes it possible to configure the manner in which calls are made to the apartments.

Within each of the options, use the arrows as selection tools or use the keypad to enter the data and use B to confirm.

4. CALL
1. CALL FILTER
2. CALL CODES

2. CALL CODES
Disabled
Exit B

Enabled: Enables the use of alphanumeric and mapped calls from the numeric keypad.

2.2.3 ADVANCED PROGRAMMING OPTIONS IN DIRECT OUTDOOR PANELS

CHANGING THE DOOR RELEASE CODE (when this has already been enabled)

It is possible to change the door release code at any time using the keypad (if this has been enabled), without having to enter the configurations. This is convenient if you wish to allow neighbours this change.

The door release code can be changed using the following sequence:

A + 3141 + Current Code (4 digits) + New Code (4 digits)

If the change is correct a confirmation tone will sound (beep-beep) and if the change is not correct an error tone will sound (bop-bop). In this case it is not possible to enter any digit with the value "A" as a "New Code".

RESTORING THE PROGRAMMING ACCESS CODE (in the event that the latter is forgotten)

If the programming access code has been forgotten, it can be restored to the default setting.

The following steps must be performed:

1. With the power supply disconnected, create a short circuit between the "Bs" and "-" (negative) terminals of the amplifier (or press the exit button if applicable).
2. Maintaining the previously-mentioned short circuit, connect the power supply of the system.
3. The outdoor panel will respond with the default code (4444) and a "beep-beep" tone will sound.
4. From then on, the short circuit between terminals "Bs" and "-" may be removed and the amplifier may be used as normal.

Note: If there is a situation in which the door release code has been assigned the same code as the default enter programming mode code, when the access code for programming is restored the access code of the door release will be immediately deactivated. This is due to the fact that the two fields of the programming parameters cannot have the same programming code.

3. DUOX PLUS AUDIO GUARD UNIT

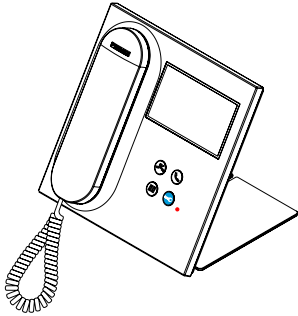

The DUOX PLUS system can be complemented with one or more GUARD UNITS (in the general entrance and/or in internal blocks) which can be wall-mounted or desk-mounted.

The central unit of the guard unit acts as a “filter” between residents of a building and visitors.

The VEO DUOX PLUS guard unit includes a 4.3” touch screen with which users may navigate through the different guard unit screens. Navigation may be performed via the icons, and selections made by pressing on the screen.

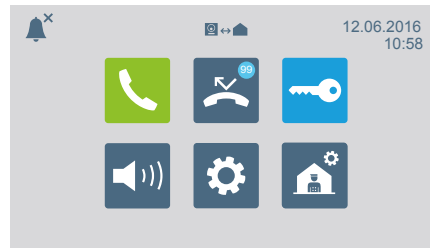

Notes:

- It is also possible to refrain from employing the outdoor panel as long as there is at least 1 Guard Unit.
- For more information, [consult manual code 970034 DUOX PLUS Audio Guard Unit Manual](#).

The guard unit includes 3 operation modes: Day, Combined and Night.

The modes which are available are:

 **DAY Mode**

All of the calls from outdoor panels are intercepted by the guard unit. The apartments/outdoor panels can call the guard unit directly.

 **MIX Mode**

The residences/panels can call the guard unit directly.

The call sounds in the residence, and call monitoring can be activated in the guard unit as well. Deactivated by default. 

 : Calls from panel to apartments will not go through the concierge. Only apartments or other concierges can call the concierge directly. (Red icon).

 : If call monitoring is activated, it would work as follows: The call rings in the apartment and if in 15 seconds there is no answer it will also ring in the concierge. From this moment on, the concierge can pick up the phone and it will stop ringing in the apartments, or vice versa. (Green icon).



When selecting the mix mode, the screen to activate/deactivate the monitoring of the guard unit call is displayed.

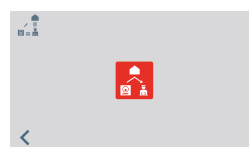

Red icon, the monitoring function in the guard unit is deactivated.

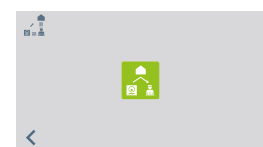

Green icon, the guard unit monitoring function is activated.

 **NIGHT Mode**

The guard unit will not receive calls of any kind.

Note: The mode that has been selected will appear on the main menu screen.

1. CONTROL BUTTONS

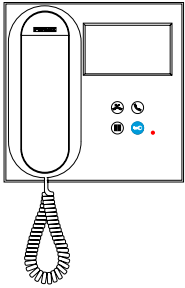

Direct access buttons to missed calls



Direct access button to communication



Menu button

1. In standby mode the main menu is accessed.
2. When active, if in the main menu the screen will shut down. In any other screen it will revert to the main menu.



Lock release button

Press to open the door while in conversation or on the "Door Release" screen.

2. OPERATION

2.1 SCREENS AND ICONS



COMMUNICATION



OPEN DOOR



MISSED CALLS



CALL VOLUME



SETTINGS

Via this icon it is possible to go to the Settings menu:

- Date and time.
- Touch volume.
- Melody selection.
- Brightness.
- Block screen.
- Parameters (Administrator Menu).



SELECTING A GUARD UNIT MODE

Selection of the guard unit mode. Enter the concierge password, which by default is 1111.

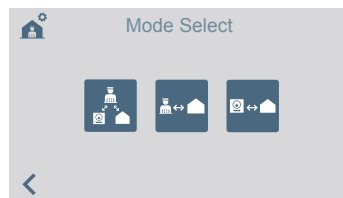
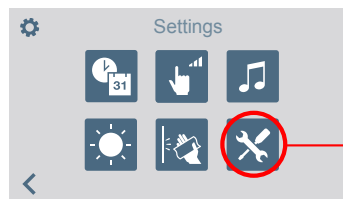
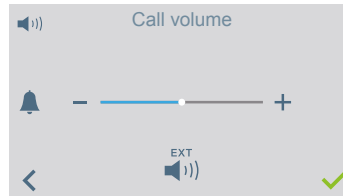
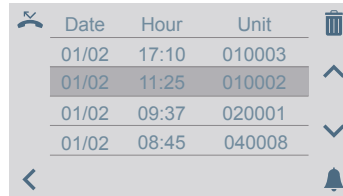
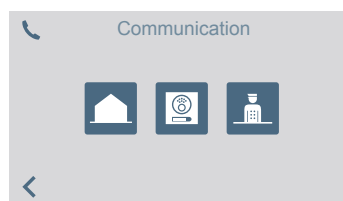
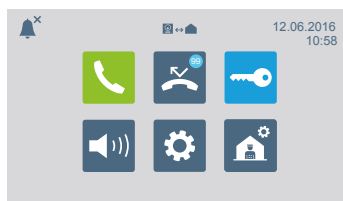

FUNCTIONING if a RELAY is configured

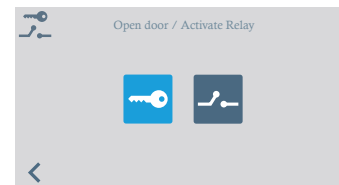
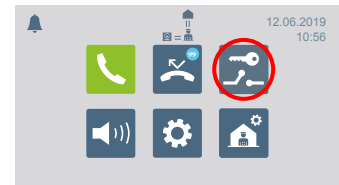

When you press the open door/activate relays icon, the screen to select one of the two options appears.



PARAMETERS (ADMINISTRATOR MENU)



The **Parameters** icon allows access to the administrator menu.

The Administrator Code (4444 by default) must be entered.

Options:

- Select language.
- Change passwords.
- Programme a terminal / Programming og audio panel pushbuttons to make direct calls to a guard unit.
- Select the guard type.
- Directory settings.

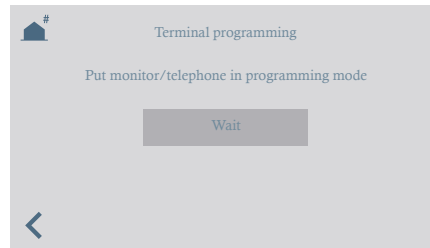
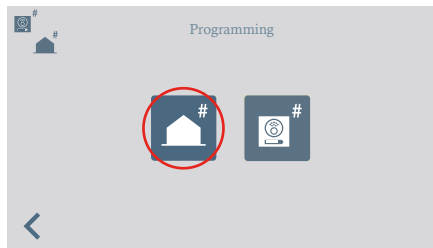
 ->  Programme a terminal

Via the guard unit, apartment terminals can be programmed. Once on this screen, the programming button needs to be pressed/selected on the telephone or monitor in order to programme.

A keypad will then follow to input the address which is to be assigned to the apartment.

It takes 2 minutes 30 seconds for this process to complete.

 ->  Programming an audio panel pushbutton to make a call to a guard unit.

To call the guard unit from an audio panel with the address 0 on a push button.

The panel must be in master mode in order to assign the pushbutton.

Configure a panel as a master: Press the SW1 button 3 consecutive times quickly. After 2 seconds, a confirmation tone will be heard, and the panel will be activated as a master.

1. While the panel is in master mode, long press SW1 for 10 seconds, a confirmation beep will be heard and the LED will flash. This indicates that the panel is in programming mode.

2. Select the  option at the guard unit.

The message will remain on the screen for 5 seconds and then the guard unit will make a call to the programmed panel as a master.

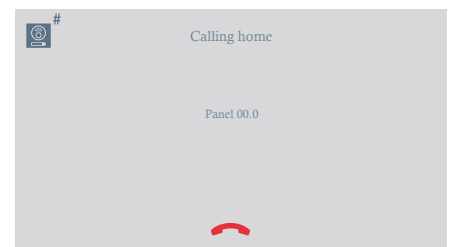
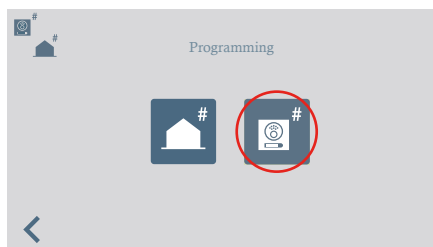

3. If the phone is picked-up, a conversation can be held as a normal call and once the call is over the guard unit will have finished its function and will return to the previous screen.

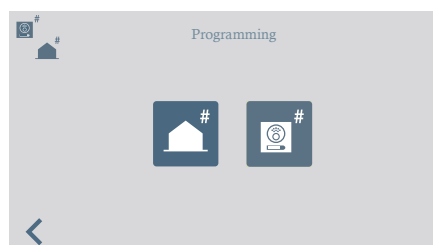

4. When you have hung up and the panel continues in programming, press the button that you want to associate with address 0. A confirmation sounds beep-beep. The pushbutton will be programmed with the address of the guard unit to call.

5. Press SW1 once to exit programming.

2.2 LED SIGNALLING

The guard unit includes an LED:

Switched on: Guard unit with power supply in standby mode (screen shut down).

Shut down: Guard unit with screen switched on or without power supply.

Blinking: Missed calls.

3. CONNECTION TERMINALS, TECHNICAL SPECIFICATIONS AND DEFAULT VALUES

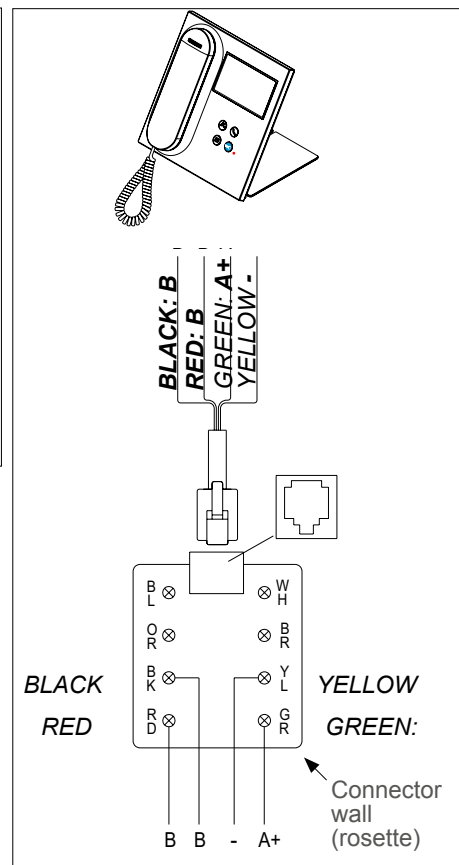
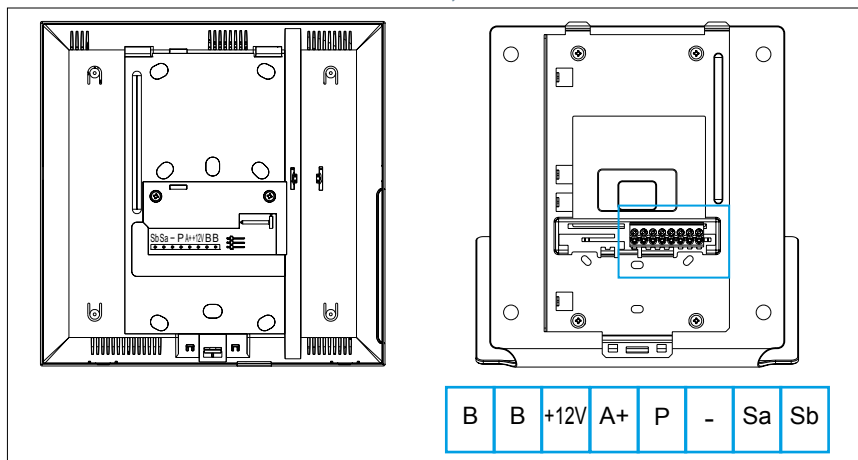

Terminals

B, B: DUOX Bus.

+12V: +12 Vdc output. Not in use.

A+, -: Electronic Extension Call Repeater ref 2040 / VDS Light / Buzzer Activator Ref. 2438.

P: Panic alarm input. Not in use.

-: Negative.

Sa, Sb: Bus RS485. Not in use.

Technical Specifications:

Power supply	18 - 24Vdc
Standby consumption	1,5 W
Call consumption (maximum volume tone)	7,7 W
Number of guard units per installation	10 in General Entrance / 10 per Block
Operating temperature	[-5° , +40°C] / [-23° , 104°F]
OSD Screen	TFT 4.3"
Resolution	Hor: 480 Line TV / Ver: 272 Line TV
Monitor dimensions (excluding support):	200 x 200 x 46 - 8" x 8" x 1.8" (Height x Width x Depth)

Default values

Language	Spanish
Installer code	4444
Concierge code	1111
Encoding	
Block	
Block Number	00
Guard Unit Number	0
Brightness	4
Time and date format	DD/MM/YYYY and 24 hours
Call volume	4
Vibrate volume	0
Conversation volume	4
Melody	BLEEPER
Guard unit mode	Night
External bell output	Disabled

4. DUOX PLUS POWER SUPPLY

The DUOX PLUS system is supplied with a voltage of 24Vdc.

The distance between the power supply and the furthest terminal it feeds depends on the type of cable, the topology of the installation and the model of the home terminals. For details see chapter 9 DUOX PLUS installations.

There are 2 models of power supplies depending on their use.

4.1 DUOX PLUS POWER SUPPLY 24Vdc/2,5A REFERENCE 4825

The power supply has a filtered POWER BUS output, to allow the power supply not to perturb the data signal. It also has a PREV BUS connection which allows more power supply to be connected to the system if required.

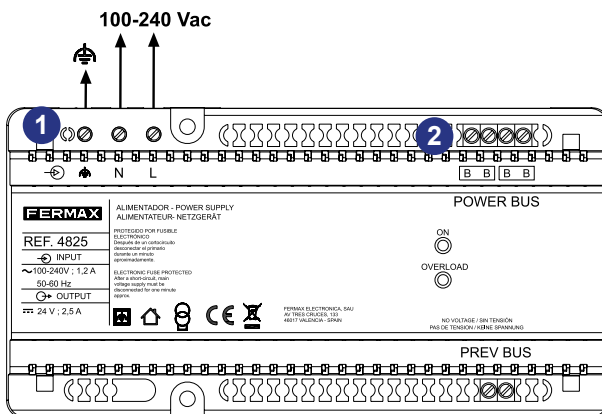

ref. 4825

- 1 **100-240V: Input voltage**
100 ~ 240 Vac.
Input frequency: 50 ~ 60 Hz.
- 2 **+ , - : Output voltage**
24 Vdc ±2%.
Output current: 2,5 A.

Connection of additional power supply

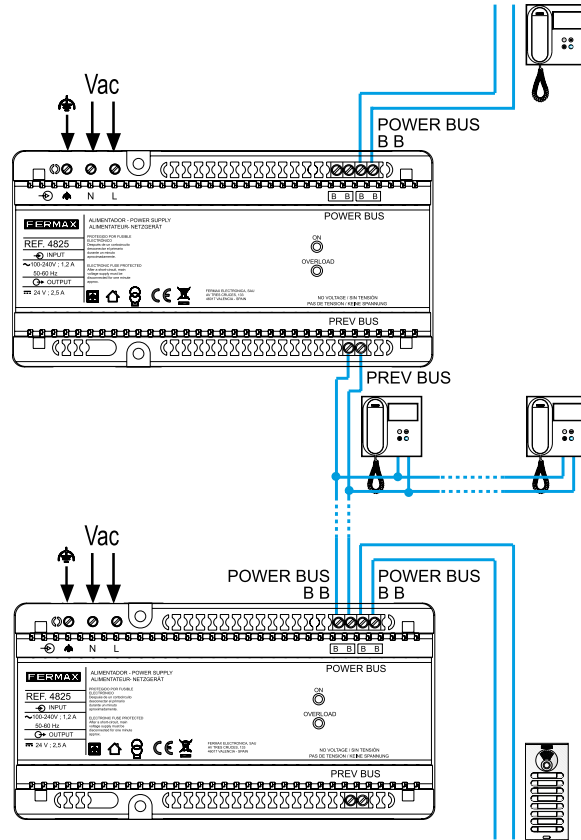

The use of this power supply is exclusive for DUOX PLUS and cannot be used in previous DUOX installations to replace the power supply set (power supply unit ref.4830 with filter ref.3244).

4.2 POWER SUPPLY 24Vdc/2A REFERENCE 4840

When the installation space is not sufficient to install the power supply ref. 4825 (DIN 10), the power supply ref.4840 could be installed, always together with the filter ref. 3289. The power supply ref. 4840 cannot be connected directly to the bus, given the characteristics of the DUOX PLUS system, because power and data are in the same wires and always requires the DUOX filter ref. 3289.

With the DUOX PLUS 2S Regenerator (ref. 3269), it will be necessary to use the ref. 4840 power supply since this equipment has a built-in filter. Therefore, this regenerator only needs the power supply.

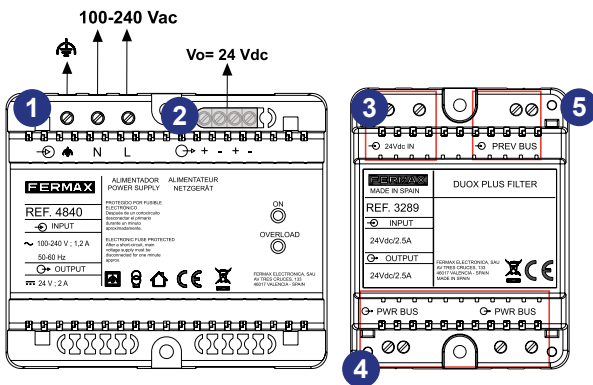

ref. 4840

- 1 **100-240V: Input voltage**
100 ~ 240 Vac.
Input frequency: 50 ~ 60 Hz.
- 2 **+ , - : Output voltage**
24 Vdc ±2%.
Output current: 2 A.

ref. 3289

- 3 **24 Vdc IN: Power supply connection**
24 Vdc non-polarised
- 4 **PWR BUS: Bus connection**
Duplicated terminal for ease of installation.
- 5 **PREV BUS:**
Bus input with coltage from another power supply.
Bus output without voltage for another device which has a power supply.

Connection of various sources

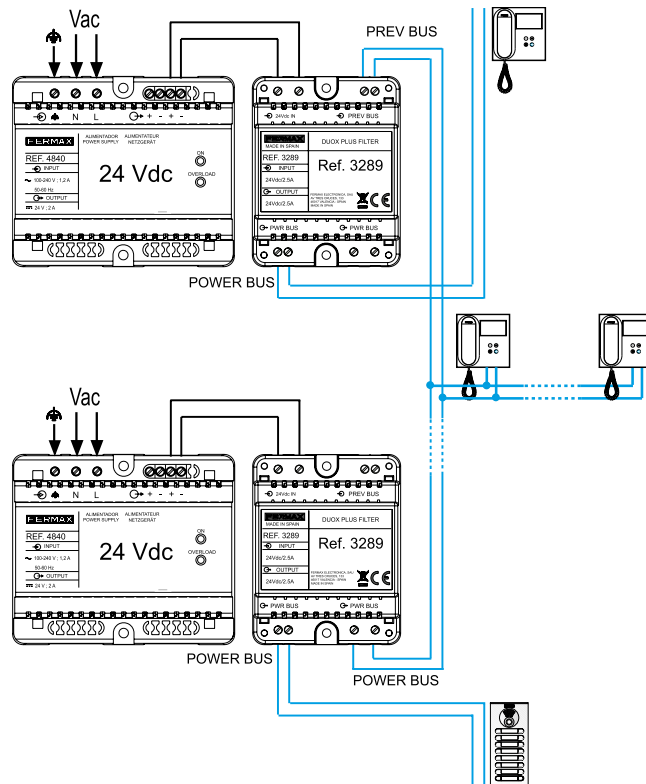

Notes:

- Extensions of terminals within the same house, may require an additional DUOX PLUS Power Supply. A maximum of 3 terminals can be installed per house

5. DUOX PLUS LINE ADAPTER

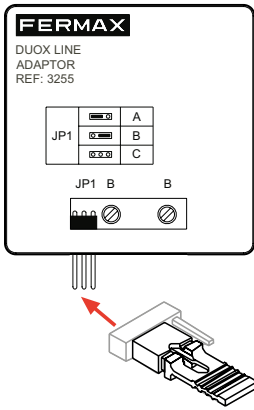

With the DUOX PLUS system it is necessary to adapt the transmission line. Line adapter ref. 3255 can be used for this purpose.

There are also other devices that include a line adapter in their structure.

This adapter balances impedances in the transmission line. This is a small element (44 x 44 x 26 mm / height x width x depth). The location and configuration of the element depend on the topology of the installation (number of risers, additional elements and so on).

We will now provide instructions about how to install and how to configure the line adapters in a suitable manner.

5.1 Devices that include a line adapter in their structure.

5.2 Where to install the adapter and how to configure it.

5.1 DEVICES WHICH INCLUDE A LINE ADAPTER IN THEIR STRUCTURE

In addition to Line Adapter ref. 3255, other DUOX devices can also be used as line adapters:

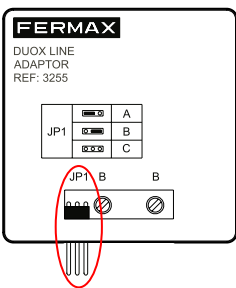

LINE ADAPTER (Ref.3255)

Includes a jumper (JP1) which enables configuration as “C” or “A”. The device includes a connection terminal to be installed in parallel with the cable of the installation. The default configuration is “C”.

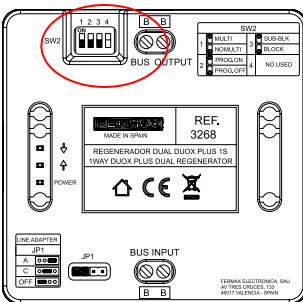

1S DUAL REGENERATOR (Ref.3268)

Line adapter integrated to the (BUS INPUT) input, with configurable adaptation (“C”, “A” or “no adaptation”) using jumper JP1. The default configuration is “C”; if no adaptation is required, remove the jumper (OFF).

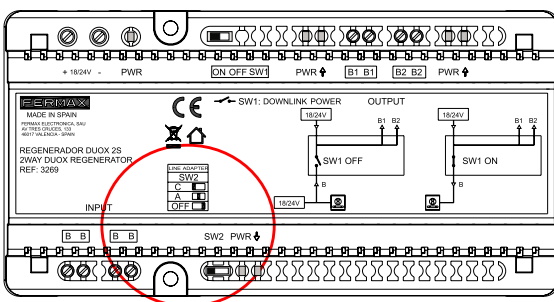

REGENERADOR 2S (Ref.3269)

Line adapter integrated to the (B, B) input, with configurable adaptation (“C”, “A” or “no adaptation”) using switch SW2. The default configuration is “NO TERM”; if no adaptation is required, leave the SW2 switch in the default position (OFF).

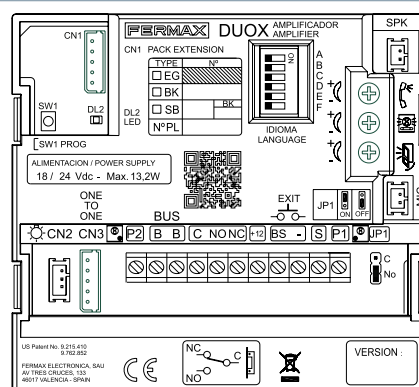
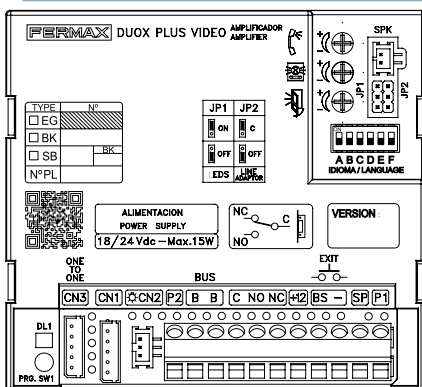

VIDEO AND AUDIO AMPLIFIERS

Line adapter integrated to the output bus, with configurable adaptation (“C” or “no adaptation”) using jumper JP2. The default configuration is “no adaptation” (OFF).

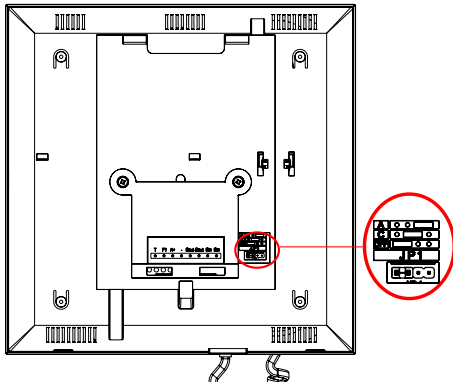

VEO MONITOR

Includes a JP1 jumper: Line adaptation bridge, which enables configuration as:

- Top: Adaptation type A.
- Centre: Adaptation type C.
- Bottom: Without line adaptation.

The default configuration is “no adaptation” (OFF).

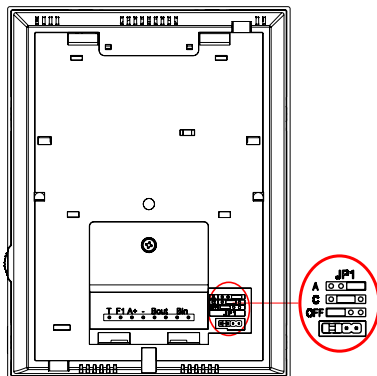

VEO XS MONITOR:

Includes a JP1 jumper: Line adaptation bridge, which enables configuration as:

- Right: Adaptation type A.
- Centre: Adaptation type C.
- Left: Without line adaptation.

The default configuration is “no adaptation” (OFF).

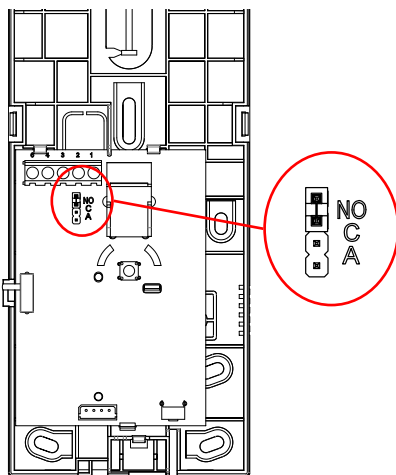

VEO TELEPHONE

Includes a JP1 jumper: Line adaptation bridge, which enables configuration as:

- Top: Without line adaptation.
- Centre: Adaptation type C.
- Bottom: Adaptation type A.

The default configuration is “no adaptation” (OFF).

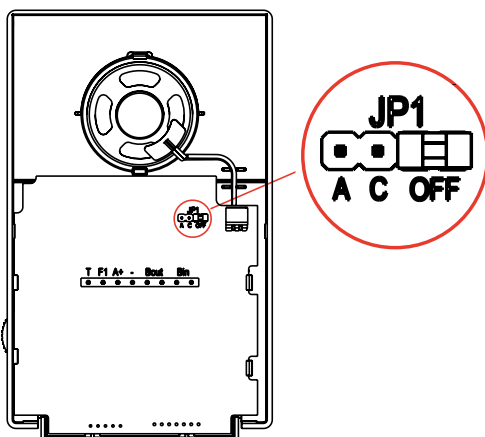

iLOFT TELEPHONE

Includes a JP1 jumper: Line adaptation bridge, which enables configuration as:

- Right: Without line adaptation.
- Centre: Adaptation type C.
- Left: Adaptation type A.

The default configuration is “no adaptation” (OFF).

5.2.WHERE TO INSTALL A LINE ADAPTER AND HOW TO CONFIGURE IT

VIDEO INSTALLATIONS

Generally speaking, when working with video installations we can state that adapters are always installed at the beginning and at the end of the riser, but the place in which the adapters should be situated will depend slightly on the number of risers and on whether the installation is in cascade format or whether it involves several terminals per derivation point.

Note: In mixed installations (audio + video) the adapters should be installed in the same way as in the video installations.

a) In cascade installations:

- One riser: position a line adapter at the first terminal and another line adapter at the last terminal.
- More than one riser: place a line adapter at the fork and a line adapter at the last terminal of each riser.
- All adapters **are configured** as "C".

Note: Depending on the type of installation, if possible the line adapter included in certain devices may be used. In this case, the one from the monitor.

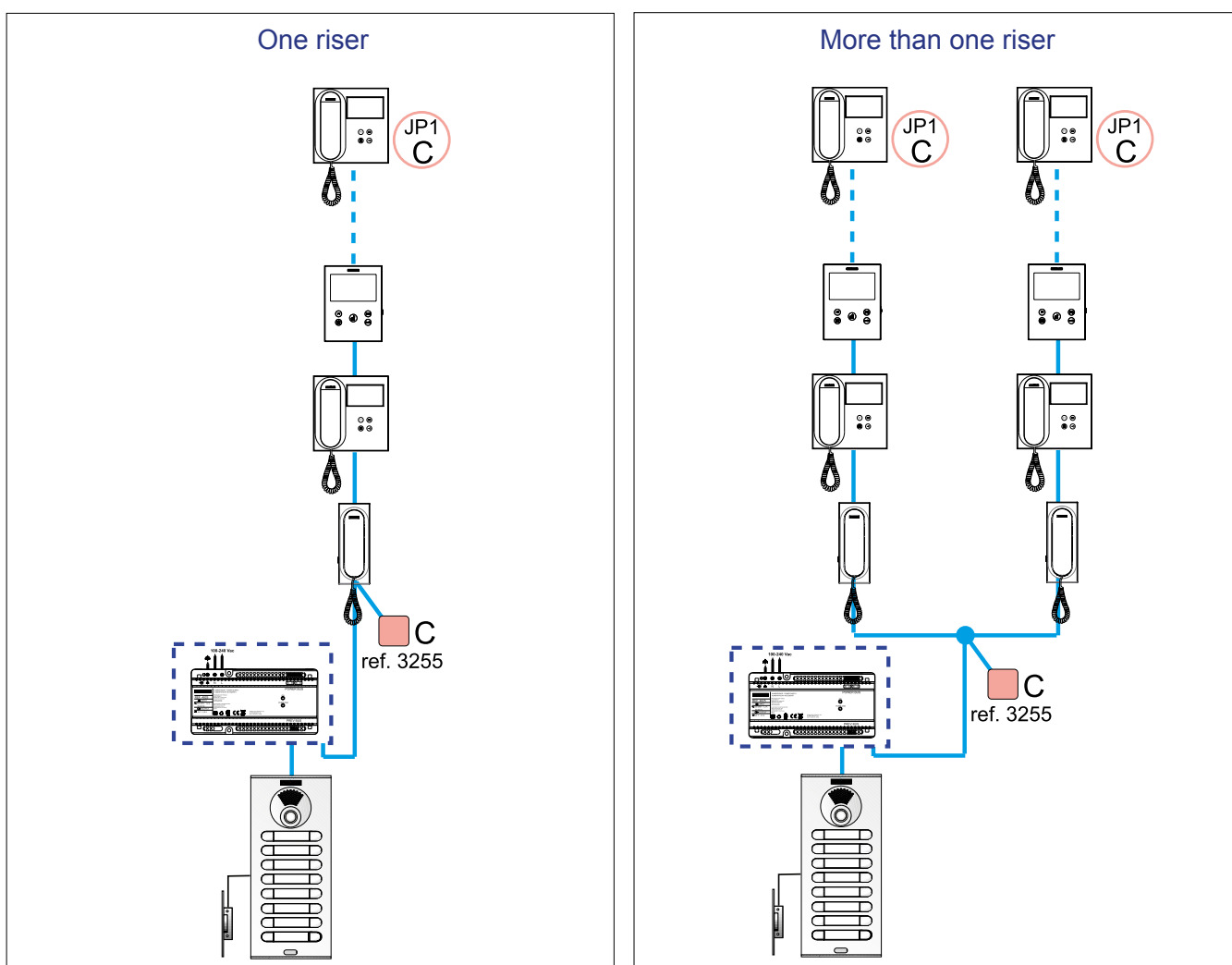

b) In installations with several terminals per storey:

- One riser: place a line adapter at the first storey fork and another line adapter at the last storey fork.
- More than one riser: place a line adapter at the first fork and another line adapter at the furthest fork from each riser with respect to the outdoor panel.
- The adapters **are configured**:
 - * At the first fork, starting from the outdoor panel, configure the adapter as "C".
 - * At the last fork of each riser, configure the adapter in "A" (the furthest away with respect to the outdoor panel).

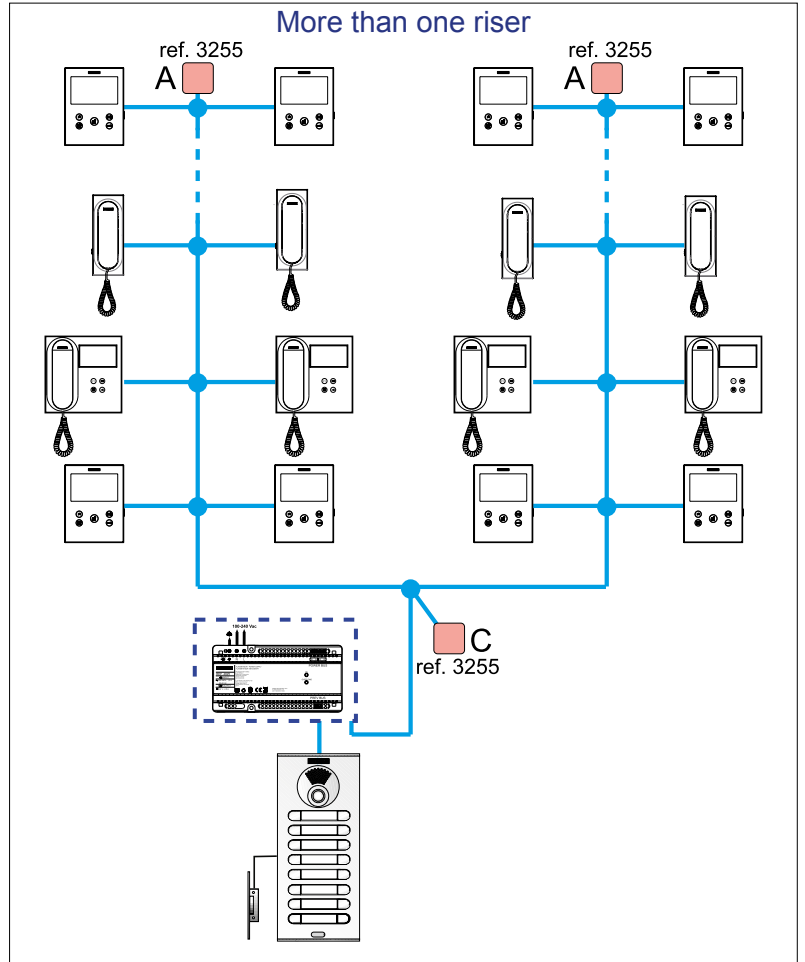
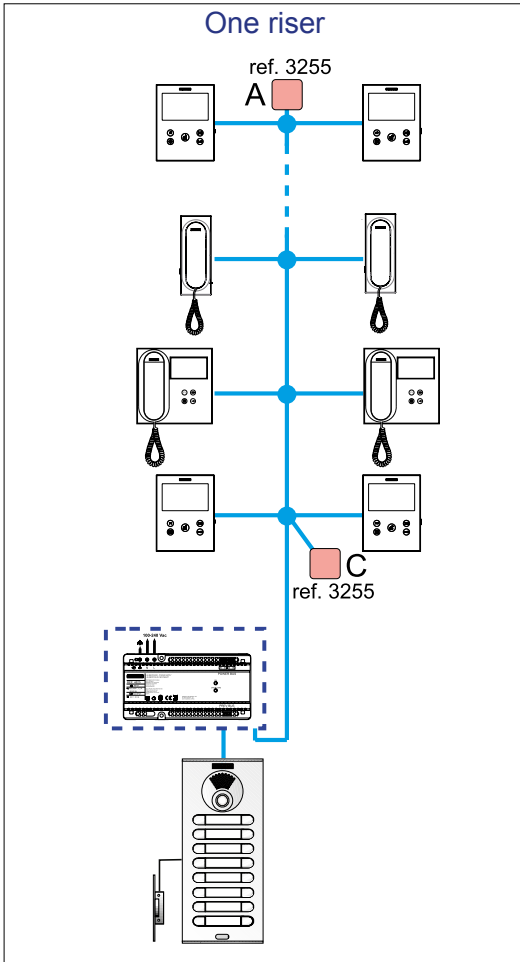

- c) In the specific event that a bus has no terminals (for example, when there are regenerators and the bus that joins these has no telephone or monitor connected).
- In this case, one adapter is connected at the beginning of the bus and another is connected at the end.
 - The adapters are configured as "C" at the beginning and at the end of the bus.

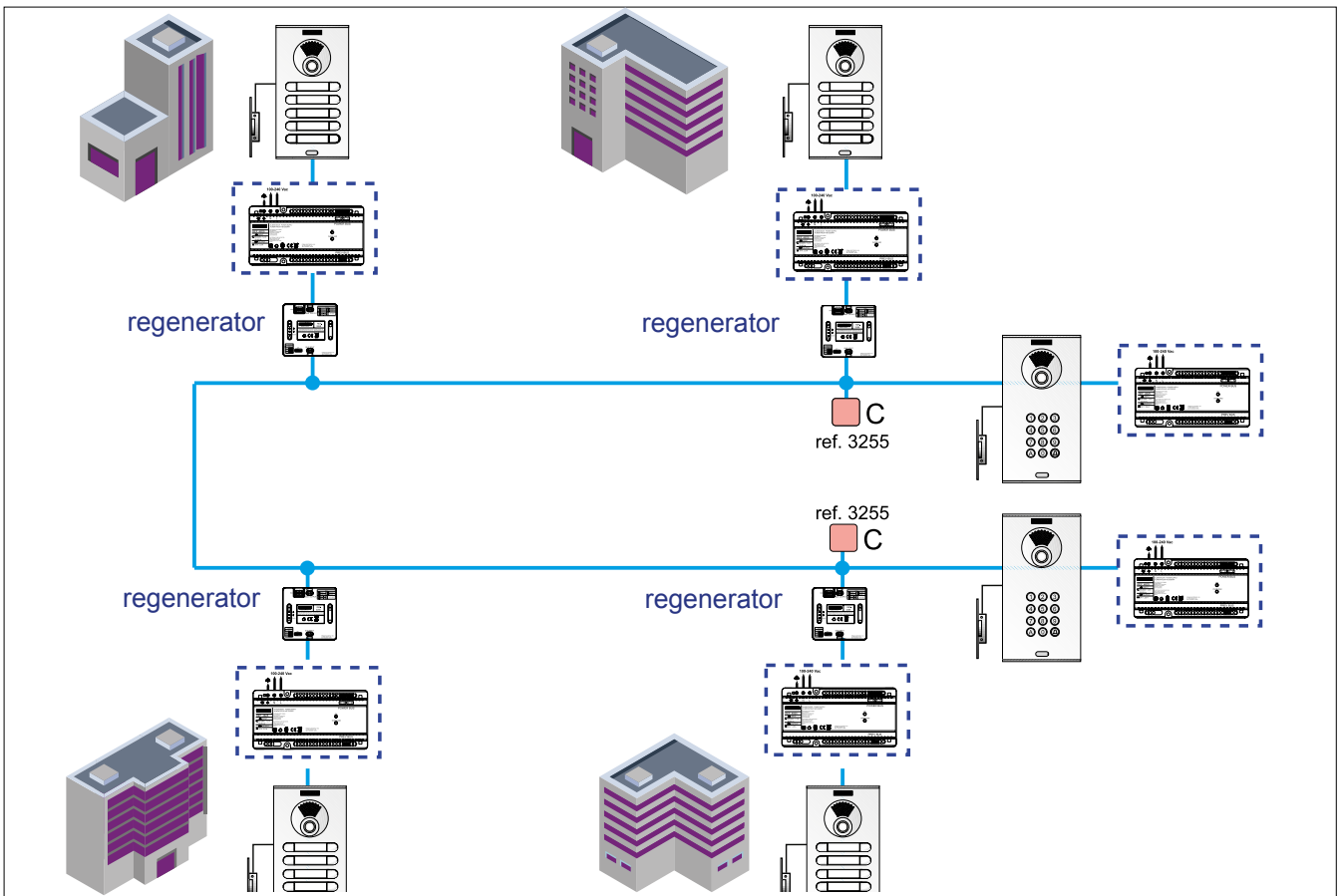

AUDIO-ONLY INSTALLATIONS

Generally speaking, when dealing with audio installations we can state that the adapters are always installed at the end of the riser.

a) In cascade installations:

- One riser: place a line adapter at the last terminal.
- More than one riser: place a line adapter at the last terminal of each riser.
- All adapters **are configured** as "A".

Note: Depending on the type of installation, if possible the line adapter included in certain devices may be used. In this case, the one from the iLOFT telephone.

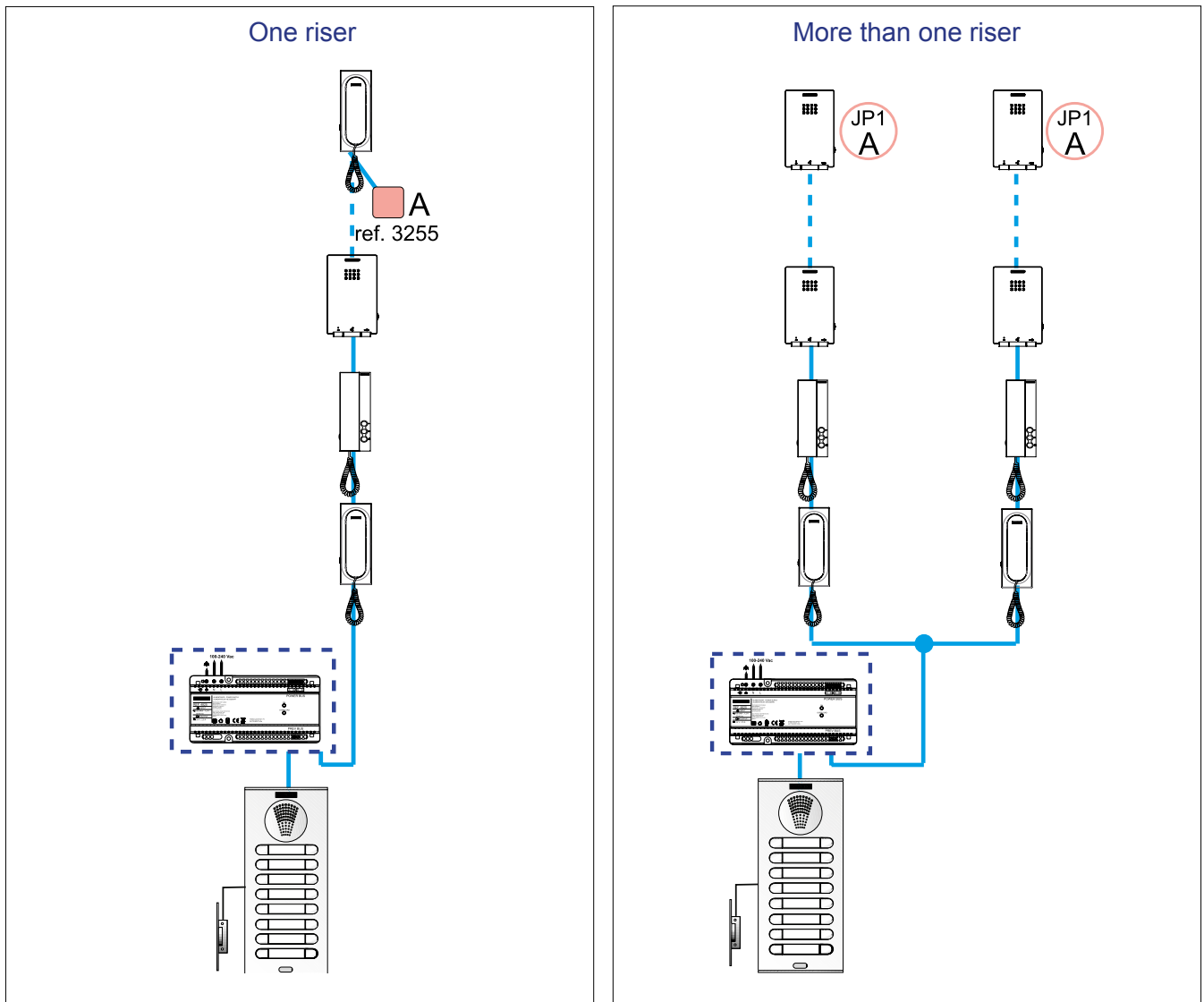

b) In installations with several terminals per storey:

- One riser: place a line adapter at the fork of the last storey.
- More than one riser: place a line adapter at the furthest fork from each riser with respect to the outdoor panel.
- The adapters **are configured**:
 - * All adapters **are configured** as "A".

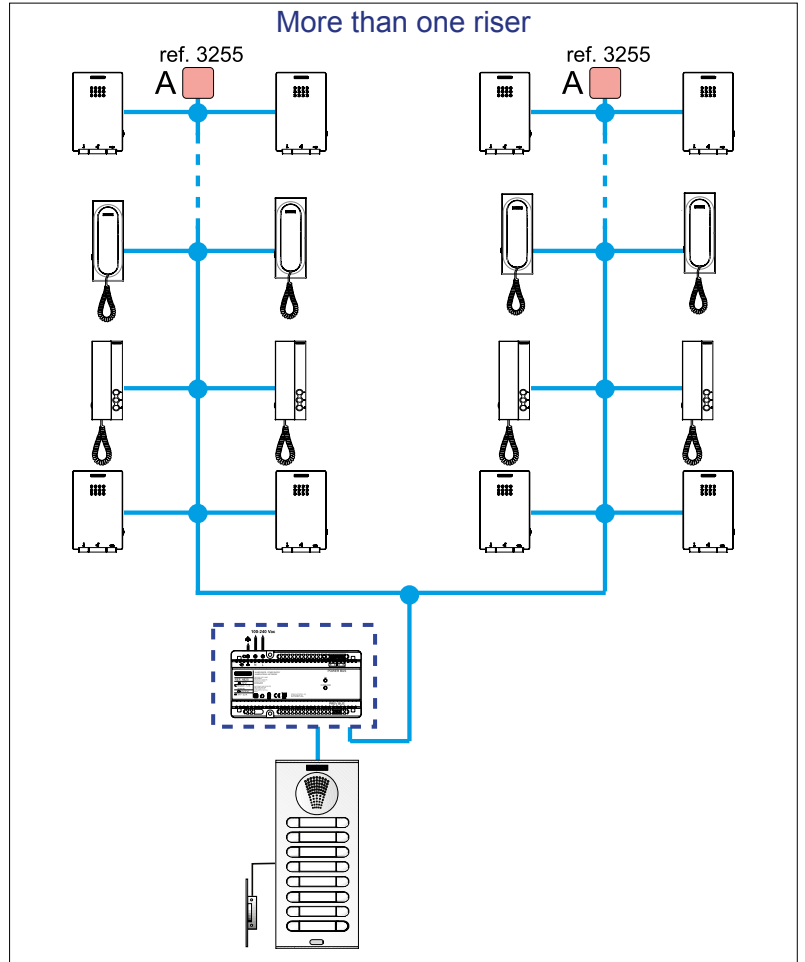
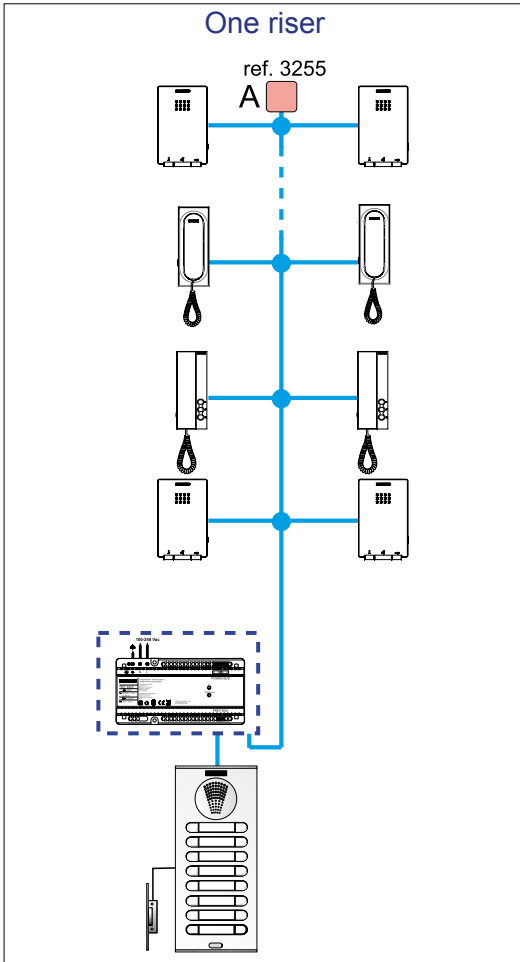

- c) In the specific event that a bus has no terminals (for example, when there are regenerators and the bus that joins these has no telephone connected).
- In this case, one adapter is connected at the beginning of the bus and another is connected at the end.
 - The adapters are configured as "C" at the beginning and at the end of the bus.

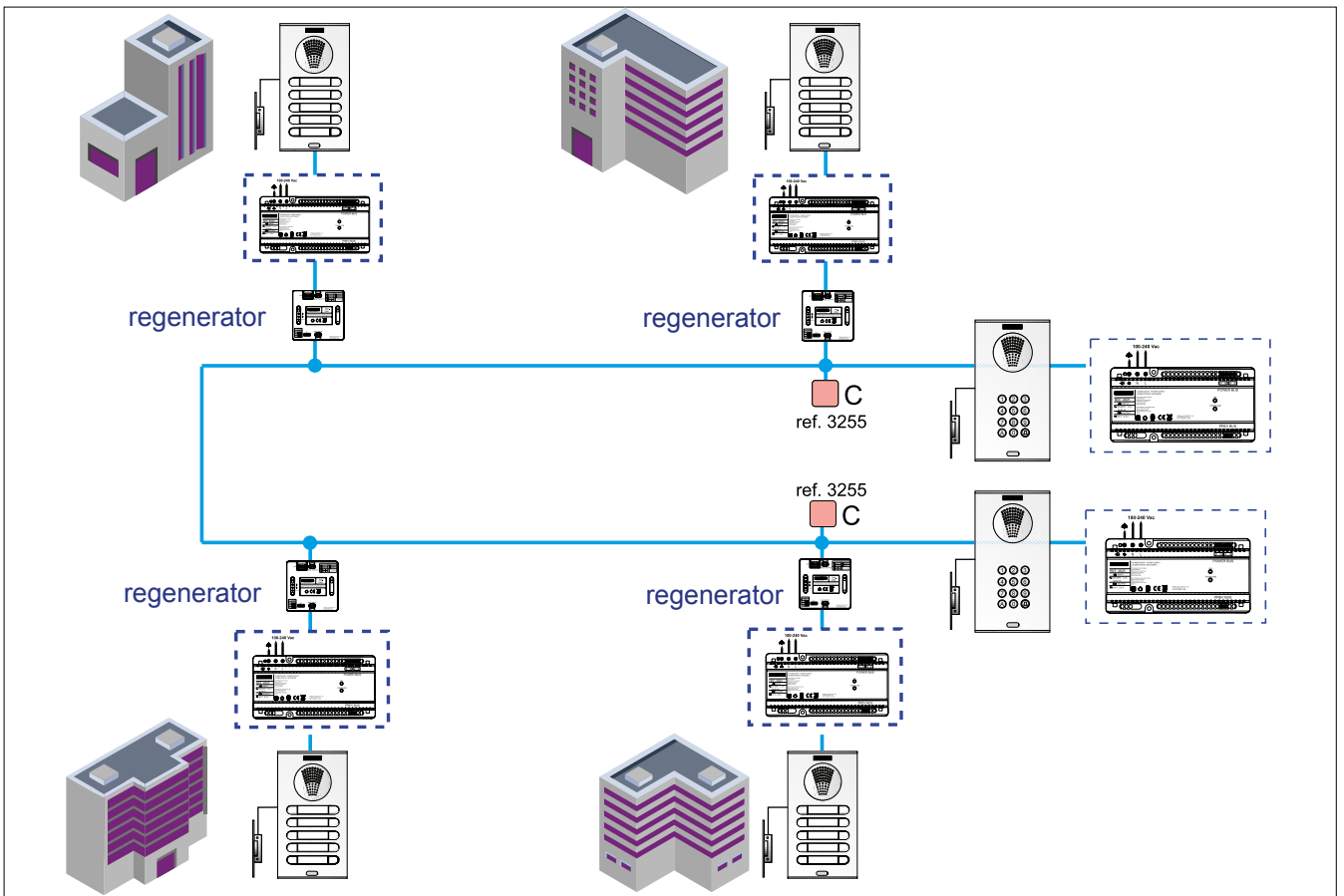



6. DUOX PLUS REGENERATOR

DUOX PLUS signal regenerators are elements that are capable of completely regenerating the DUOX signal received in any of its ports, both in amplitude and waveform, bidirectionally, thus maintaining the same audio and video quality at any point of the bus. In addition to regenerating the signal, they allow the electrical isolation of the sections between which it is connected, both at the short circuit and signal transmission level. For all these reasons, regenerators have become a great tool in those installations where different types of cable have to be mixed.

The main role of the regenerators is to increase the distances, risers and number of terminals in an installation, as well as to quickly reinforce the signal if it has been degraded.

In fact, the signal regenerators now allow the passage of current, being able to solve problems at points of the installation where it was not previously possible before without adding a DUOX PLUS power supply set.

For the regenerator to work properly where it is installed, the level of the signal received must be good enough to be decoded. For reference, a regenerator can be placed at the same point where a monitor can be operated correctly.

The signal obtained at the output of a regenerator is exactly the same as the one obtained at an outdoor panel or an apartment terminal, so the output of each signal regenerator can be considered a new installation. If, for example, you have the maximum 40 DUOX PLUS monitors in a basic installation as a signal limitation, after getting a DUOX PLUS regenerator you could add another 40 monitors, since at the output of the regenerator you will have a new signal both in terms of amplitude and waveform, without the effects of possible reflections that were in the previous section of the installation.

The different regenerators have an integrated line adapter in their port (see section 5.1 Devices that include a line adapter), to be used if necessary.

As many generators may be used as is necessary in parallel installation, keeping in mind that the maximum number of regenerators that can be installed in series is 5 (different models can be combined).

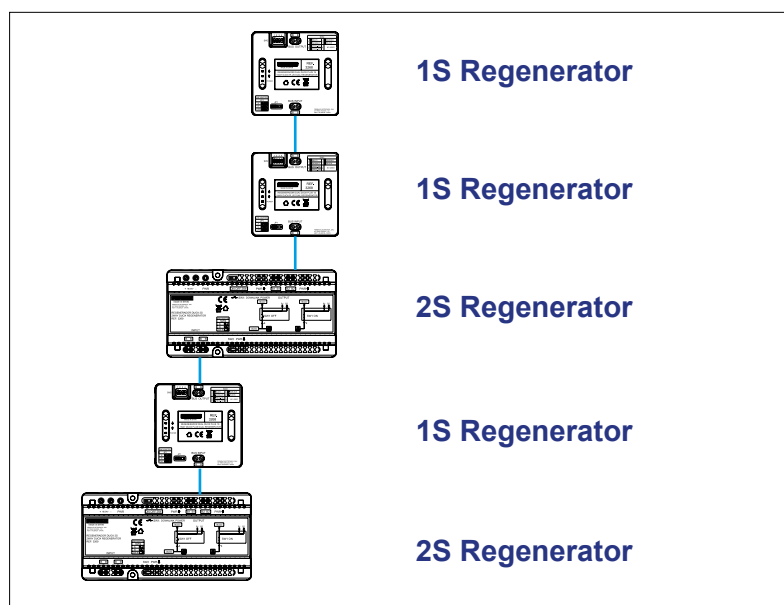

To adapt to the needs of each installation, there are two types of signal regenerator:

6.1 DUAL DUOX PLUS 1S REGENERATOR (REF. 3268)

This signal regenerator consists of two ports, which are bi-directional. The sections of the installation that are connected to each side of the regenerator are electrically isolated from each other, each section being protected against problems such as short circuits or reflections in the following section.

The device is supplied with power from the DUOX bus through any of its ports, but never from both simultaneously. If power is detected in both ports, the regenerator turns off to protect itself, so it is recommended that one of its ports is connected to the PREV terminal of the previous power supply set. You can check if there is power in a port simply with a multimeter in Continuous Current mode, measuring the difference in potential between B and B.

The regenerator has an LED indicator called PWR that is lit red continuously when the device is appropriately powered. If it is off, either not enough power is supplied to the device (the minimum input voltage is 15Vdc) or power is supplied via the input and the input port at the same time. In addition to this indicator, there are two LED indicators next to the direction indicator icons. These icons light up green when there is data transmission in the direction indicated by the arrow. For example, when a call is made from a board connected at the INPUT port to a monitor connected at the OUTPUT port, you should see both LEDs illuminate indicating that there is information being transmitted in both directions.

Finally, the regenerator incorporates a microswitch to select the operating mode and programming of the device. The operating modes are listed below:

Operating mode Single channel signal regenerator

In this operating mode, the regenerator takes the existing signal at either of its two ports, decodes it and reconstructs it at the other port. This way, both sections of the installation are isolated from each other and any distortion or attenuation suffered is removed from the signal, thus restarting all the terminal ranges and quantities.

To select this mode, the first microswitch must be in the OFF position. The main uses of the regenerator when working in this mode are as follows:

1. Extension of the distance from the panel to the first splitting.

Thanks to the new feature that allows the passage of current from one terminal to another of the regenerator's terminals, it is possible to place a signal regenerator that allows the regeneration of the signal that travels between the outdoor panel and the rest of the installation, so that the maximum possible distance between the panel and the register can be achieved regardless of the topology of the installation, in other words, the installation distance counter is reset, starting from zero in the register.

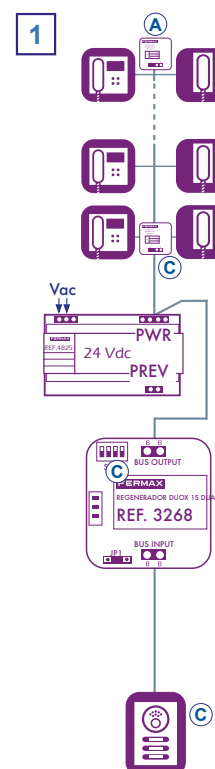

2. Extension of the number of terminals in the installation.

When the limits of a basic installation are exceeded (see section 9.2), the quality of the DUOX signal is compromised and may not be decoded correctly at the panels or terminals. However, when a regenerator is used, provided it can decode correctly, the signal at the output of the device will be perfectly reconstructed in shape and amplitude. With a power supply unit, therefore, the limits of a basic installation can be reached again in the section behind the regenerator, in other words, the limit per number of devices of a basic installation is reset (see section 9.2.).

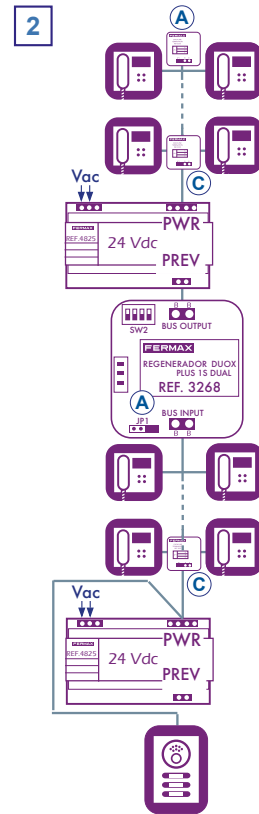

3. Regeneration of the signal at any point in the installation:

Thanks to the new feature that allows the passage of current (up to 1.6A) through the regenerator, if in an installation signal problems are encountered, for example due to the complexity of the topology, it is possible to add a regenerator to quickly reinforce the signal without also adding a power supply to feed the section connected behind the regenerator.

The number of devices that can be connected behind the regenerator without adding an additional power supply depends on the section of the cable used and the type of terminal, as shown in the table below:

Cable	No Wifi	Wifi
1 mm ²	28	14
0.5 mm ²	24	12
0.2 mm ²	12	12

Furthermore, it is necessary to remember that, as no additional power supply is added, the total number of devices in the installation must not exceed the maximum allowed by the power supply (See section 9.1: Power source).

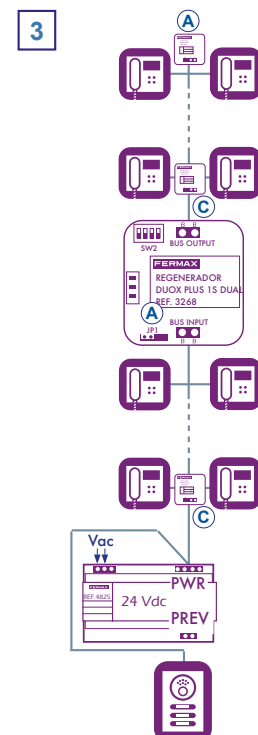

Multichannel Signal Regenerator Operating Mode

When there are different interior blocks in an installation, it is possible to isolate the communication channel of each of them. This way there can be simultaneous communications in each block. See Double Communication Channel annex. Just add a multi-channel regenerator in each block and program it in the same number of blocks as monitors and panels located in that inner block.

PROGRAMMING of the directions.

In this operating mode, the block or sub-block number must be programmed. To do so, set Microswitch 1 (MULTI) and 2 (PROG.ON) to ON. (Microswitch 4 not in use).

Microswitch 3 must be ON if you want to program the SUB-BLOCK and OFF if you want to program BLOCK. When the regenerator is switched on (with power), the block or sub-block number programming mode is entered, depending on the choice of microswitch 3. The POWER LED blinks quickly until the block/sub-block number is programmed via the bus.

To program the address, make a call from the panel of that block/sub-block, an auto power-up (not allowed with sub-block) or press F1 from a monitor of that block/sub-block (connected to the BUS OUTPUT terminal). You have 60 seconds to program your address, at which time the interface exits programming mode. As soon as the device is programmed with an address, the POWER LED will flash at a slower rate.

Once the programming is finished, set the microswitch 2 to OFF, to avoid accidental reprogramming.

When working in multi-channel mode, up to 5 interior blocks, the regenerators can be powered from the same source as the general input:

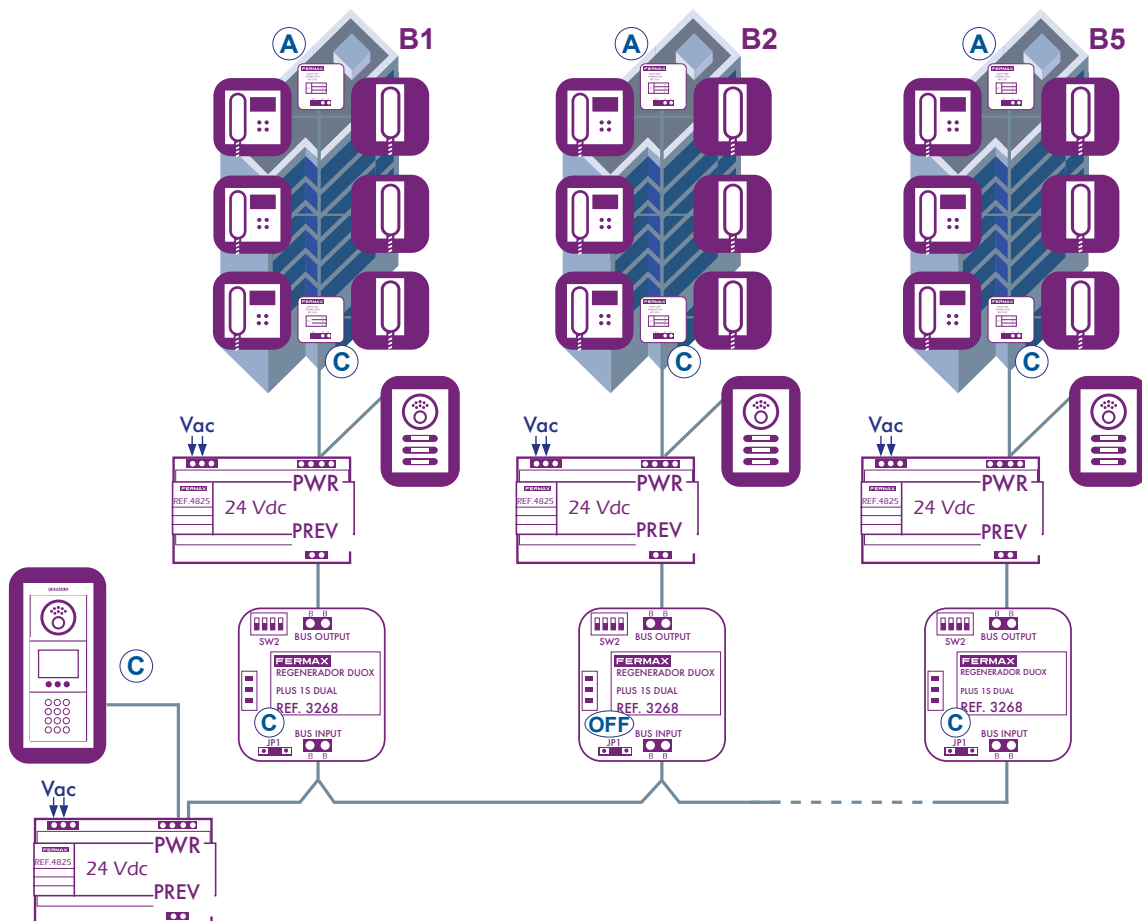

For more than 5 blocks, additional power will be needed:

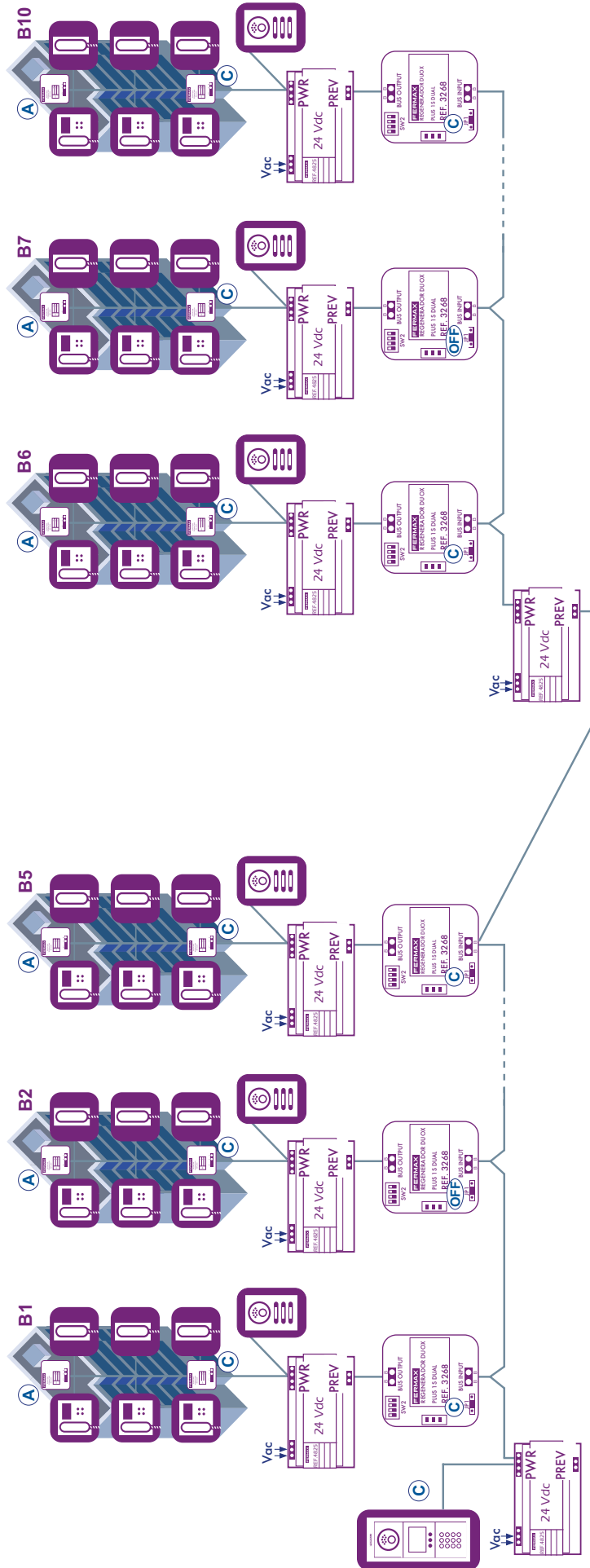

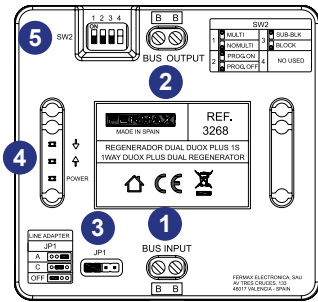

- 1 B B: BUS INPUT Connector**
DUOX Bus: power and data.
The input terminal has a build-in line adaptation, configurable via JP1, see 3.
- 2 B B: BUS OUTPUT Connector**
DUOX Bus: power and data.
- 3 JP1: Line adapter bridge (BUS INPUT)**
 - o To the right: Adaptation type A.
 - o To the centre: Adaptation type C.
 - o To the left: OFF. No line adaptation, (by default).

- 4 Red « POWER » LED:** If it is on, it indicates that the device has power.
Green LED «↑» / «↓»: When this LED is on, it indicates data traffic in the direction marked by the arrow. During a call, both LEDs should flash. If one does not light up, it indicates insufficient signal in that direction.

5 SW2: Programming Microswitches - Configuration

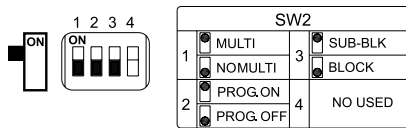

- 1: ON - Multichannel Regenerator. // 1: OFF - Regenerator (NO multichannel).
- 2: ON - Programming activated. // 2: OFF - Programming disabled.
- 3: ON - Sub-Block selection (for multichannel). // 3: OFF - Block selection (for multichannel).
- 4: No function.

TECHNICAL SPECIFICATION

Supply voltage	18 - 24 Vdc
Standby consumption	1,8 W.
Maximum consumption	2,16 W.

6.2 DUOX PLUS 2S REGENERATOR (REF. 3269)

The DUOX PLUS dual output regenerator is a device with three bi-directional ports, which are electrically isolated from each other. The incoming signal on any of its ports will be completely regenerated, both in waveform and amplitude, by the other two ports simultaneously.

This regenerator takes the power through a dedicated source, connected at the power input, which will be distributed via the device outputs. The B1 and B2 output ports will always be powered, while the power provided through the INPUT port is optional and its activation or deactivation is selected using the SW1 switches:

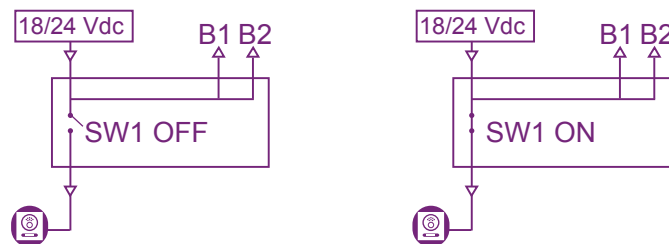

Examples of use:

Riser power supply + Panels

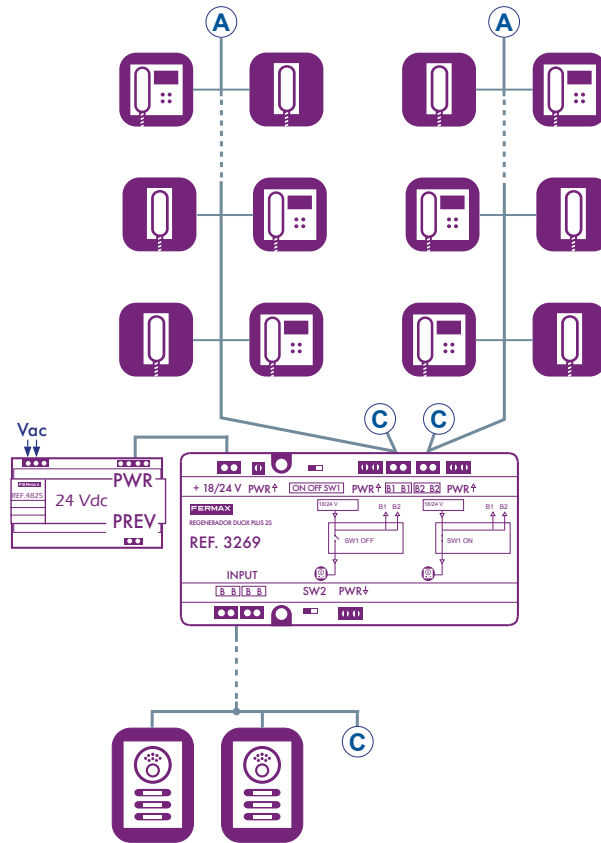

Risers only power supply

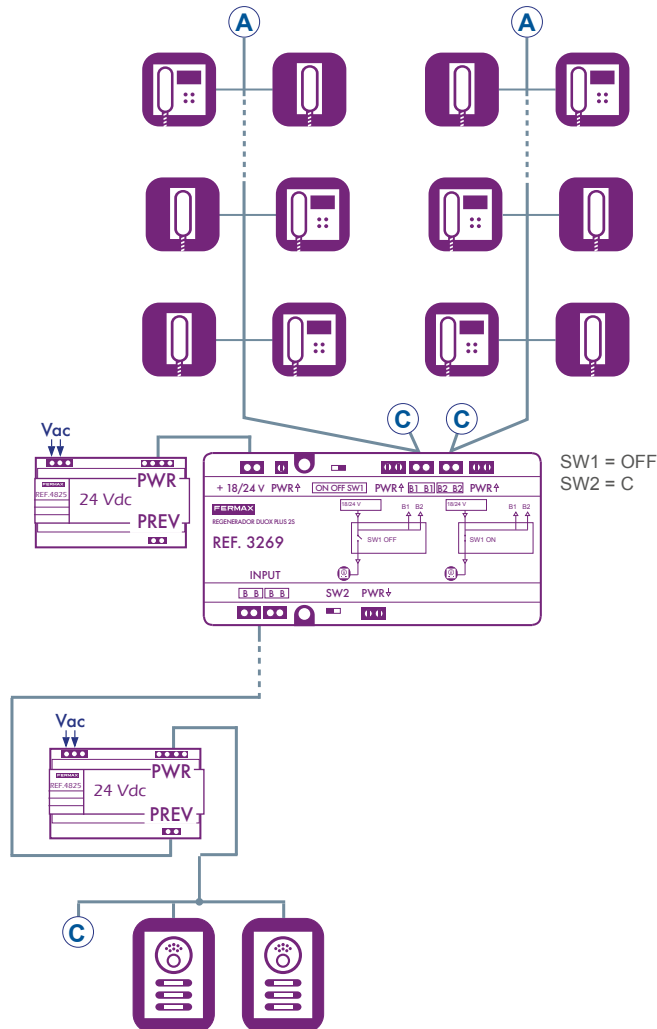

Signal regeneration at one point in the installation

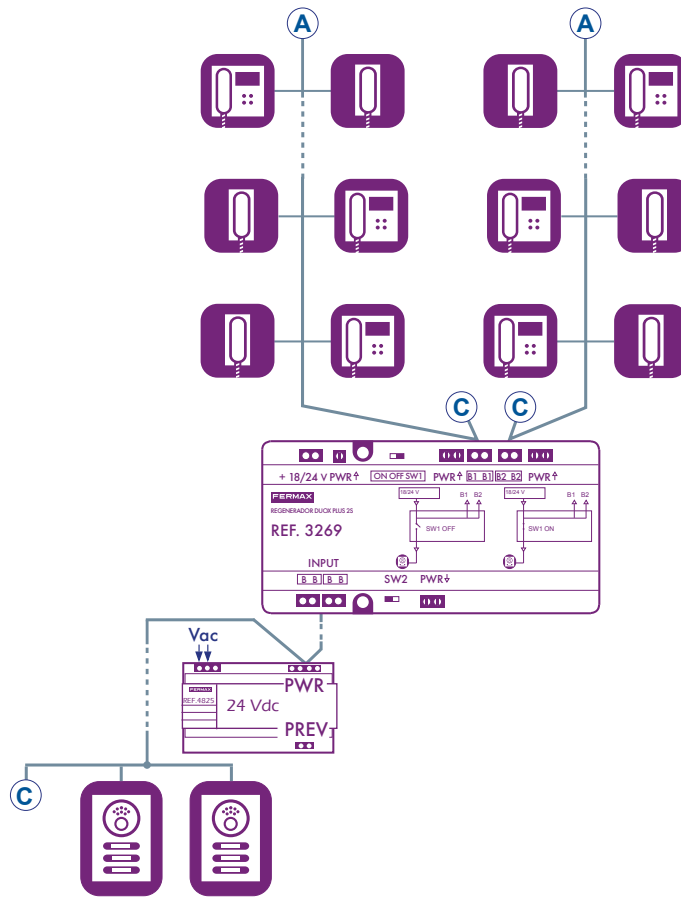

The maximum load current that can pass through the regenerator is 2.5A, regardless of whether this load is connected to a single output or distributed among the available outputs.

The device comes with a line adapter integrated in the INPUT port, whose value is configurable using the SW2 switch.

In addition to the above-mentioned switches, two LEDs can be found on each side of the device's ports. In each case, the PWR LED will be red when there is a DC power supply to that port, while the DATA LED will be green when there is data transmission. For example, in the case of a call from a board connected to the INPUT port to a monitor connected to the B1 output, the DATA LED of both ports will be green, while the DATA LED of the B2 port will remain off.

This regenerator is particularly suitable for those installations where either there are several risers or the connections are star connections

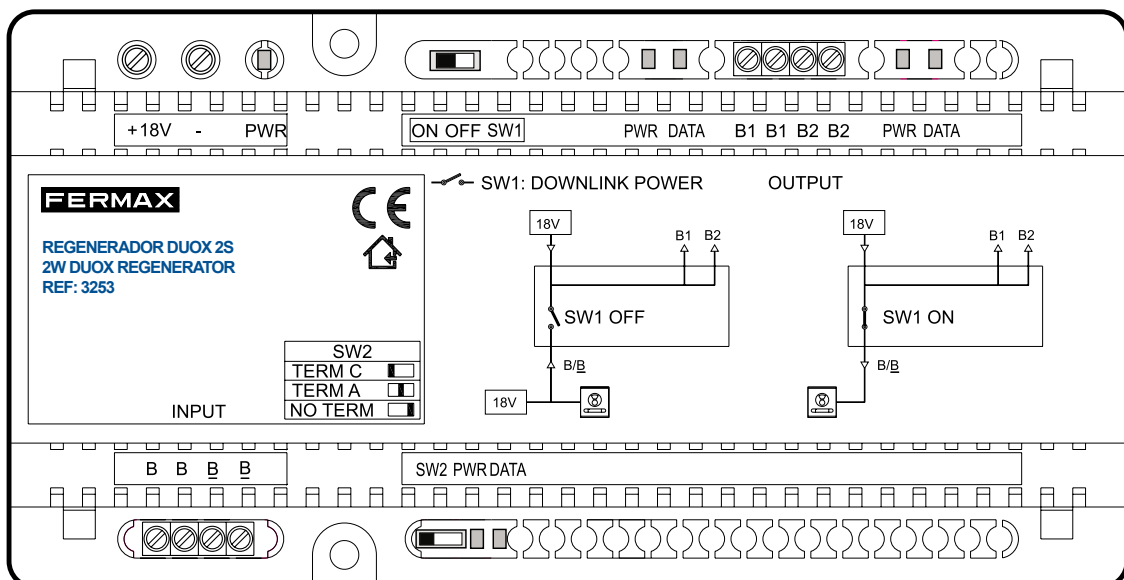

CONNECTORS

a) System connection terminals

a1) **18/24V**: input 18 - 24 Vdc.

a2) **B, B (INPUT)**: Terminals connecting the bus of the input riser. Duplicated, to facilitate connections in parallel.

a3) **B1, B2 (OUTPUT)**: Terminals connecting output risers 1 and 2.

b) Red PWR signalling LEDs: are associated with the power supply.

b1) **+18/24V**: Red LED signals power supply input of 18 - 24 Vdc. If the power supplied is less than 15.5V (approximately), the LED switches off. If there is a short circuit, this LED will switch off.

b2) **B, B (INPUT)**: power being supplied to the input riser. If the voltage is below 15V (approximately), the LED switches off. If there is a short circuit, this LED will switch off.

b3-b4) **B1, B2 (OUTPUT)**: power being supplied to riser 1 or 2. If the voltage is below 15V (approximately), the LED switches off. If there is a short circuit, this LED will switch off.

c) Green LEDs:

These indicate a sufficient level of input signal on each port. During a call, the INPUT and OUTPUT LEDs should flash showing where the terminal that was called is located. If any one of them does not light up it indicates that there is insufficient signal in that direction.

c1) **B, B (INPUT)**: data in the input riser.

c2-c3) **B1, B2 (OUTPUT)**: data in riser 1 or 2.

d) **SWITCH SW1**: Switch for selecting the operating modes.

e) **SWITCH SW2**: Switch to select the line adaptation.

TECHNICAL FEATURES

Power Supply	18 - 24 Vdc
Standby power usage	1,88 W
Maximum power usage	2,64 W
Operating Temperature	[-5°, +40°C]
Minimum input data signal (no ripple)	1 Vp

6.3 COMPARISON BETWEEN REGENERATORS

The main differences that can be noted between the different regenerators are:

- Size and format.
- Inputs / Outputs.
- Power supply.
- Primary use.

Device	Regenerator 1 Output (Ref. 3268)	Regenerator 2 Outputs (Ref. 3269)
Specifications		
Size / Format	89 (H) x 86 (V) x 26 (P) mm (DIN 6)	175 (H) x 90 (V) x 60 (P) mm (DIN 10)
Inputs	1	1
Outputs	1	2
Supply	Power supply or from the BUS	Power supply
Primary use	Regenerate Isolate Additional channel	Regenerate Isolate Risers

7. APARTMENT TERMINALS

The DUOX PLUS system includes a wide range of apartment terminals, for both door installations (telephones) and video door installations (monitors).

The apartment terminals enable the user to establish audio/video communication with the outdoor panel, to open the door, to call the concierge and so on.

The maximum number of terminals per apartment is three. In order to expand the number of terminals in an apartment it may be necessary to add a power supply set depending on the number of existing apartments and monitors, the topology, the type of cable and so on.

After installation, DUOX PLUS apartment terminals require a simple programming process through which the terminal is assigned a “call code/call direction”. When a call is made from the outdoor panel to the terminal programmed with this code, the terminal receives the call and is able to establish communication with the outdoor panel. *See sub-section 1.4 Operating principles of the DUOX PLUS system.*

Monitors:

- DUOX PLUS monitors should be installed in video installations (with video panels). Video installations can be extended with additional monitors and/or telephones.
- DUOX PLUS monitors can be programmed within seconds, directly from the terminal menu, which makes it possible for one single person to programme the installation.
- Monitors with DUOX PLUS technology:
 - VEO and VEO WiFi Monitor.
 - VEO XS and VEO XS WiFi Monitor.

Telephones:

- DUOX PLUS telephones can be installed in telephone-only installations (audio installations), in mixed installations including telephones and monitors or as an additional device in monitor installations.
- Programming the DUOX PLUS telephones is very simple.
- Telephones with DUOX PLUS technology:
 - VEO Telephone.
 - Loft Extra Telephone.
 - iLOFT Telephone.
 - Loft Basic Plus Telephone.



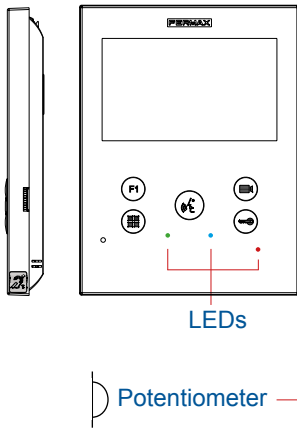

7.1 VEO XS AND VEOXS WIFI MONITOR

CONTROL BUTTONS / LEDS



-  Digital menu for settings and configuration of internal parameters. (If the monitor has been programmed).

-  In conversation, push to open the door.
In stand-by mode, call to the concierge (if applicable).

-  Auxiliary function (check with your installer).

-  In standby mode, press and the screen will display the possibility of performing auto switch-on with different outdoor panels. Press Outdoor Panel **0**, Outdoor Panel **1**, **General Outdoor Panel** in sequence (depending on the availability of panels).
 - Panel 0 of the monitor block.
 - Panel 1 of the monitor block.
 - Panel 0 of the General Entrance.

*Note: - If a call is received from another panel, when the conversation has been completed, for 15 seconds, **auto switch-on** will happen with that panel.*

-  Audio activation and hang-up (hands-free operation).

-  Induction loop label. Situated on the side of the monitor.
(Depending on).

-  Ring tone volume setting.
On standby: At the MINIMUM, call disconnection (Do Not Disturb Mode, flashing red LED).
Conversation in progress: Upstream audio setting.

● **Red LED:**

- Switched on. Monitor is idle.
- Intermittent. Do Not Disturb mode has been activated.

● **Blue LED:**

- Intermittent. Monitor not programmed (*idle*).
- Switched on. Conversation in hands-free audio mode.
- On/Intermittent. Conversation in simplex audio mode

● **Green LED:** According to configuration.



Led Connectivity (only VEO XS WiFi).

- Intermittent fast blinking. APP and monitor under synchronization.
- On. Monitor connected.
- Intermittent slow blinking. Monitor has answered but the APP can not answer.
- Off. Monitor not paired.

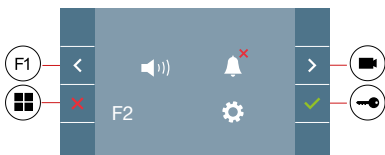

The VEO XS monitor includes an OSD menu which is managed using the monitor pushbuttons to access the functions for using and programming the terminal. The icons displayed on the screen are controlled using the corresponding pushbuttons located on the monitor.

CONNECTIONS

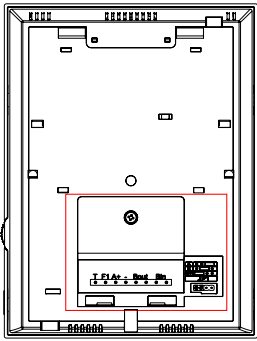

Monitor Connectors:

Bin, Bin: Data, audio and video input.

Bout, Bout: Data, audio and video output (for cascade connection).

T, -: Apartment door call button (P1).

A+, -: Option of connection with the following devices:

- Call extender ref. 2040.
- Light and buzzer commander ref. 2438.

F1: Additional function.

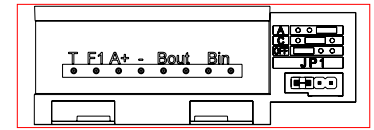

JP1: Integrated line adapter bridge

- Right: Adaptation type A.
- Centre: Adaptation type C.
- Left: Without line adaptation: OFF, (by default).

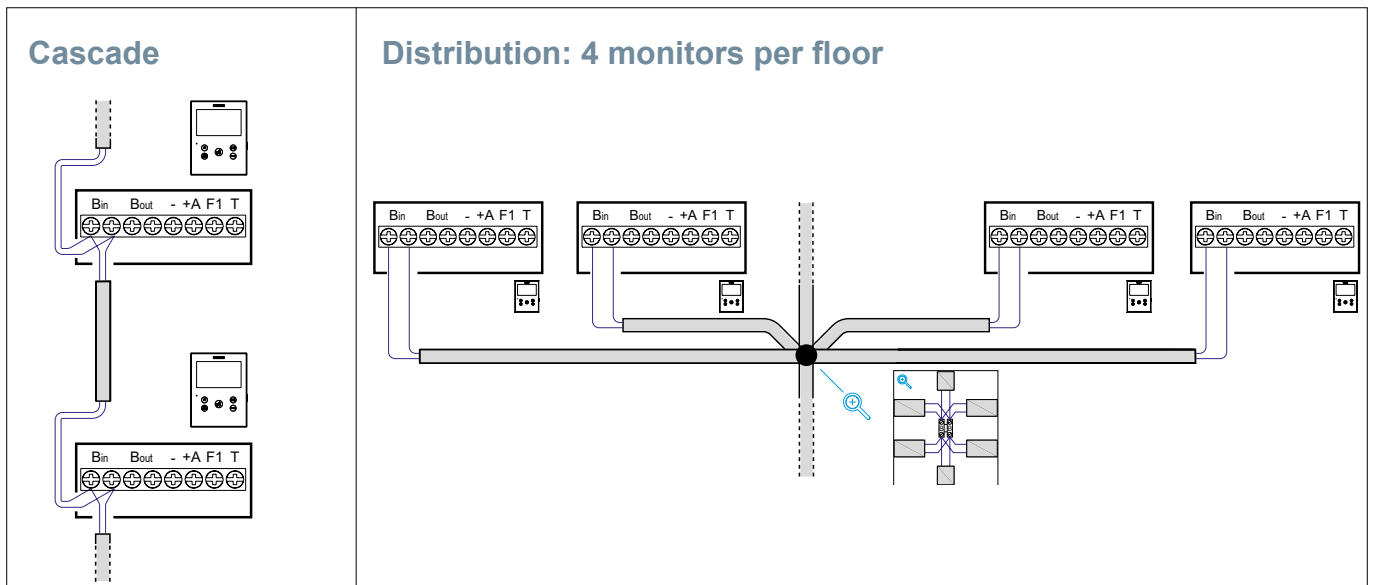

MONITOR PROGRAMMING

Notes:

- Before programming the monitor, the outdoor panel should be set as the master outdoor panel (panel is configured as Master by default).

1. INSTALLATION

Monitor supplied with power for the first time.

A blue LED, blinking slowly, indicates that the monitor is not programmed.

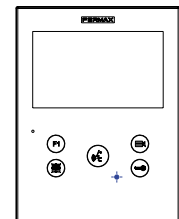

2. ENTERING THE PROGRAMMING MENU

Press the  button to access the "programming menu"..

PROGRAMMING FROM AN OUTDOOR PANEL

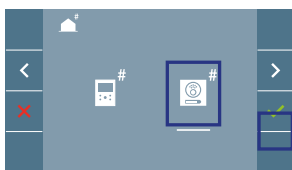

PROGRAMMING MENU

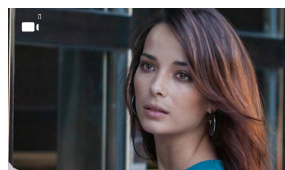
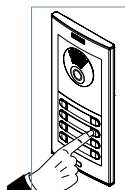

Select the  icon and confirm with  , (a "beep" will be heard in the monitor).

Press the corresponding pushbutton from the outdoor panel (call code for that monitor). A different ring tone will sound, confirming the programming of the monitor. After a few seconds, the monitor will return to standby mode.

PROGRAMMING FROM THE MONITOR (only one person is required to complete the programming process)

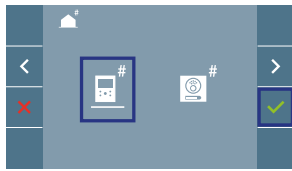

Select the **>** icon  and confirm with .

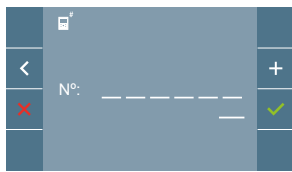

Each time that **+** is pressed, the number increases (starting from 1) and the arrow **<** is used for scrolling.

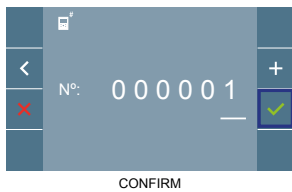

The white cursor indicates the entry position of the digit. Confirm with  to complete the process.

3. MONITOR SETTINGS

VIDEO SETTINGS

When there is an image on the monitor after pressing the , (or if a call is received without establishing audio communication), press the  key to display the video settings.

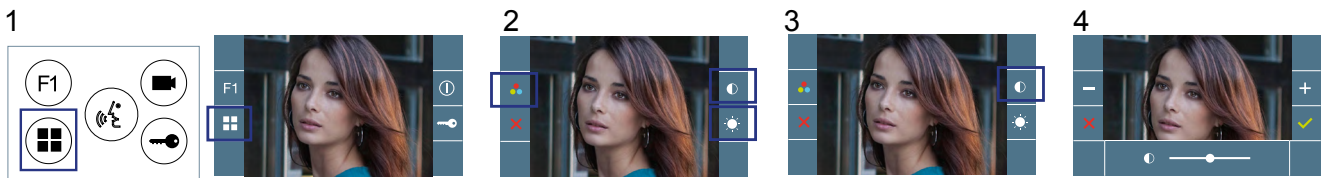

Select the settings option and increase and decrease using **+** and **-**.

AUDIO SETTINGS

While the audio channel is open, press the  button and the menu for this setting will appear on the screen.

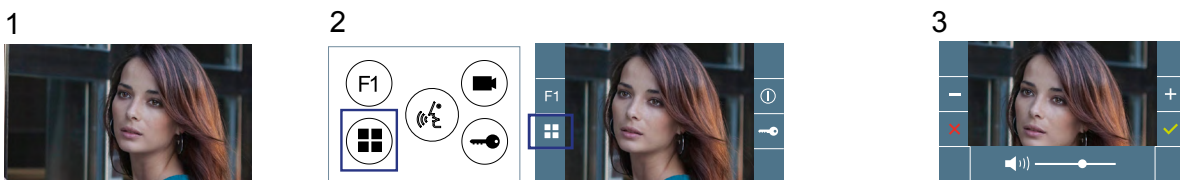

Increase or decrease using **+** and **-**, until obtaining the required regulation.

Note: Maximum conversation time: 90 seconds.

USER SETTINGS

Access User Parameters.

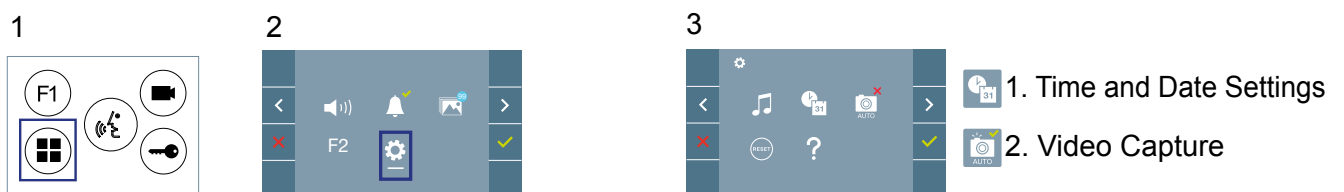

Select the **>** icon  and confirm with .

1. TIME AND DATE SETTINGS

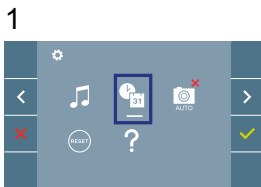

Select the icon and confirm with .



Use to select the date format. Once this has been selected, confirm using .

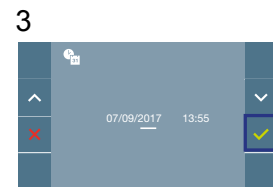

Select the time and date with and confirm . To navigate through the settings .

Non-programmed date: 01/01/2017 (by default). The icon will appear, indicating that the date is not correct (default date). If the power supply is lost, the default date will be restored.

Note: If an image is captured without the date having being programmed, the icon will be displayed.

Icons notifying of a non-programmed date::

User Menu screen

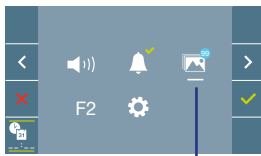

Image display

Communication screen

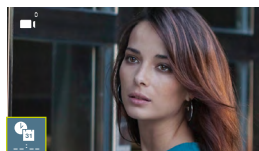
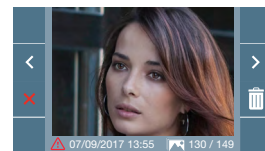

Image Display screen



2. ACTIVATION/DEACTIVATION OF VIDEO CAPTURE

The monitor can take an automatic picture within 5 seconds of receiving a call from an outdoor panel. According to the European Union legislation about data protection ((EU) 2016/679), the capture of images may be restricted. This feature is deactivated by default in all monitors, although can be activated at your own responsibility.

Furthermore, the legislation may force to place a sign next to door stations, indicating that monitors can capture images. You can download it at <https://www.fermax.com/intl/en/corporate/utilities.html>.

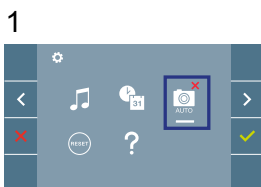

Select the icon and confirm with .

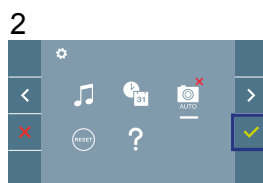

Push to activate/deactivate the function.

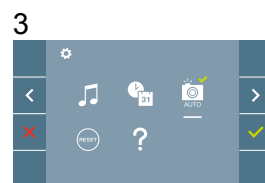

TECHNICAL SPECIFICATIONS

Power supply	18 - 24 Vdc
Standby consumption	VEO XS: 0,8 W / VEO XS WiFi: 1,3 W
Maximum consumption	VEO XS: 6,5 W / VEO XS WiFi: 6,9 W
Maximum consumption with induction loop	14,4 W
OSD screen	TFT 3,4"
6-digit address	000001...999999
Operating temperature	[-5° , +40°C] / [23° , 104°F]
Dimensions	165 x 125 x 21mm - 6.5" x 4.9" x 0.8" - (Height x Width x Depth)
Conversation modes	
hands-free	by default
simplex	push to talk: push button to talk, release to listen

FUNCTIONING

1. FUNCTIONING: PAIRING. Call forwarding.

The VEO XS WIFI DUOX PLUS monitor allows access to new Fermax services, such as call divert, through its own cloud. To use this service, the monitor must first be connected to the Internet through a pairing process. To do this, use the Blue app, which is available on Google Play or the Apple App Store.

Monitor settings. Pairing process.

The monitor pairing process, using the Blue app, can begin once the user has registered and logged in.

The DUOX PLUS monitor is only compatible with 2.4GHz WiFi.

How to connect the monitor to the Internet.



1 Open the application and log in.

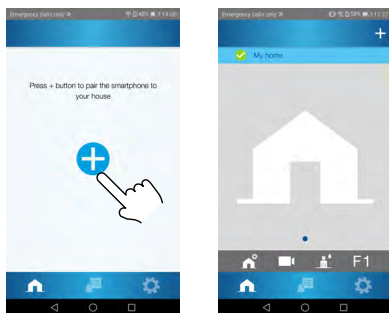

2 Click on the button + in the middle of the default screen, or in the top right if there are already some properties listed.

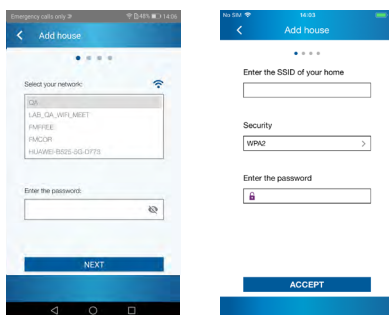

Android

iOS

3 The user will need to select the desired WiFi network to connect the monitor.

Select (if using Android) or enter (if using iOS) the desired SSID (network name), enter the correct password to connect and click NEXT/ACCEPT.

4 The user will then need to open the monitor's connectivity menu:



4a Press the MENU button, to access the User Menu.

4b Relationship between buttons and navigation menu. The white line below the icon shows which function is currently selected.

4c Select the connectivity menu on the monitor.

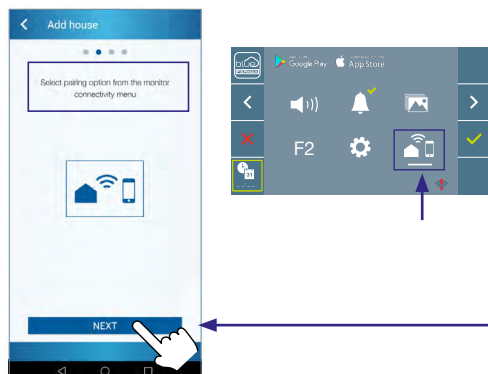
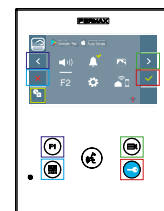

5 Once the connectivity menu is selected, press to access.

Click NEXT when ready.



6 A QR code will show on the monitor screen.

A MAC code is provided on screen in case the WiFi router uses MAC filtering.



7 The application will be ready to scan that code. Point your mobile phone at the QR code on the monitor screen so the code is within the green square on the mobile screen.

8 The application and monitor will begin to synchronize. The white WiFi LED on the monitor will start flashing.

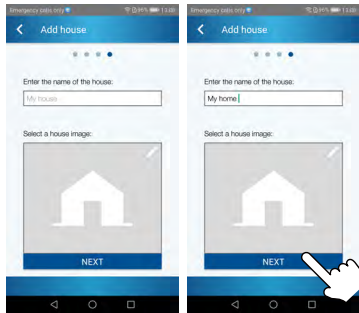
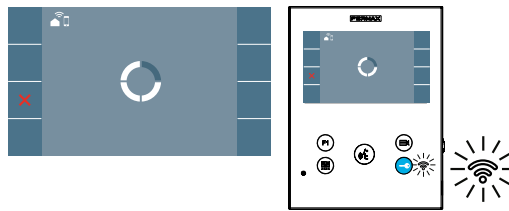

9 The screen to add a property will appear:
 - Name
 - Image (optional)
 Enter data and press NEXT.



11 If the WiFi network and credentials provided are correct, the monitor will connect to the Internet and the process will have been completed successfully.



12 The application will show the new linked house as available and connected (green tick ✓) and the monitor will show that connection was successful. The white WiFi led will stay now stay on.

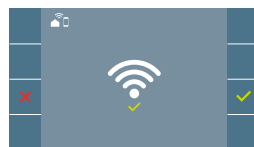

Monitor pairing process confirmation message.

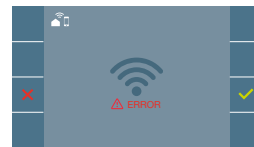

An error message will appear in the monitor pairing process if there is a problem.

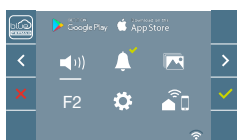

13 Once connected, the WiFi signal strength will appear in the bottom right of the monitor user menu.

WiFi signal strength icons displayed in the menu:



Between 0% and 20% or monitor not paired.



Between 20% - 40%



Between 40% - 60%



Between 60% - 80%



Between 80% - 100%

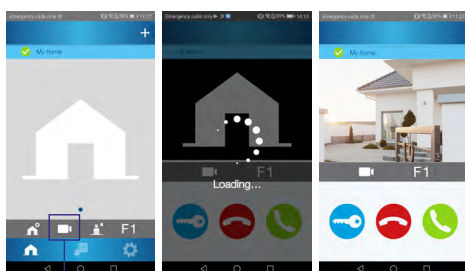

Auto-on

14 To test the call divert function, the user can select auto-on and see whether it connects to the outdoor panel, (as long as it is not in use).

7.2 VEO AND VEO WIFI MONITOR

CONTROL BUTTONS / LEDS

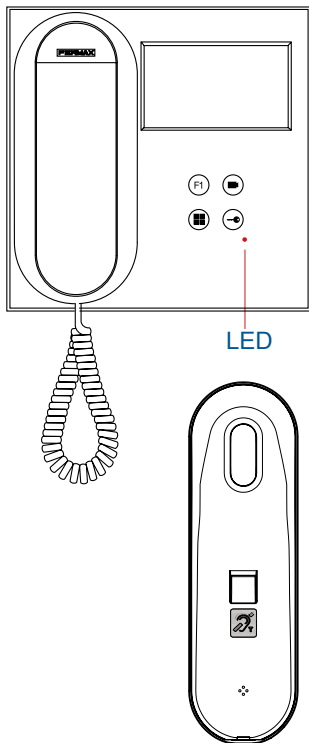

- Digital menu for settings and configuration of internal parameters. (If the monitor has been programmed).
- In conversation, push to open the door.
In stand-by mode, call to the concierge (if applicable).
- Auxiliary function (check with your installer).
- In standby mode, press and the screen will display the possibility of performing auto switch-on with different outdoor panels. Press Outdoor Panel 0, Outdoor Panel 1, General Outdoor Panel in sequence (depending on the availability of panels).
 - Panel 0 of the monitor block.
 - Panel 1 of the monitor block.
 - Panel 0 of the General Entrance.

*Note: - If a call is received from another panel, when the conversation has been completed, for 15 seconds, **auto switch-on** will happen with that panel.*
- Induction loop label. Located at the internal part of the receiver.
(Depending on the model).

● Red LED:

- Switched on. Monitor is idle.
- Intermittent fast blinking. Monitor not programmed.
- Intermittent slow blinking. Do Not Disturb mode has been activated.



Led Connectivity (only VEO WiFi).

- Intermittent fast blinking. APP and monitor under synchronization.
- On. Monitor connected.
- Intermittent slow blinking. Monitor has answered but the APP can not answer.
- Off. Monitor not paired.

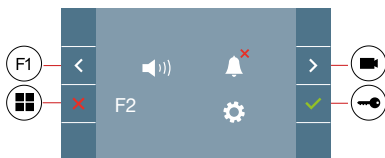

The VEO monitor includes an OSD menu which is managed using the monitor pushbuttons to access the functions for using and programming the terminal. The icons displayed on the screen are controlled using the corresponding pushbuttons located on the monitor.

CONNECTIONS

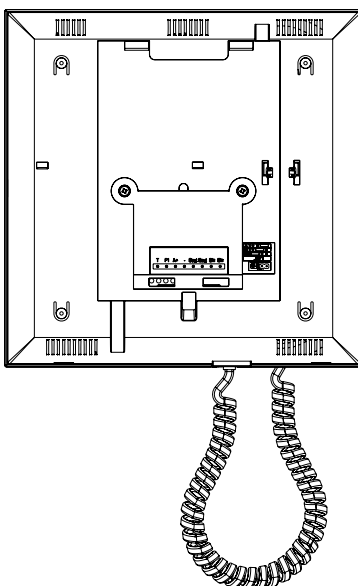

Monitor Connectors:

- Bin,Bin: Data, audio and video input.
- Bout,Bout: Data, audio and video input (*cascade connection*).
- T, -: Apartment door call button (*P1*).

A+, -: Option of connection with the following devices:

- Call extender ref. 2040.
- Light and buzzer commander ref. 2438.

F1: Additional function.

JP1: Integrated line adapter bridge

- Top: Adaptation type A.
- Centre: Adaptation type C.
- Bottom: Without line adaptation: OFF, (by default).

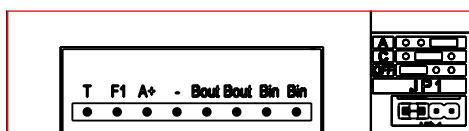

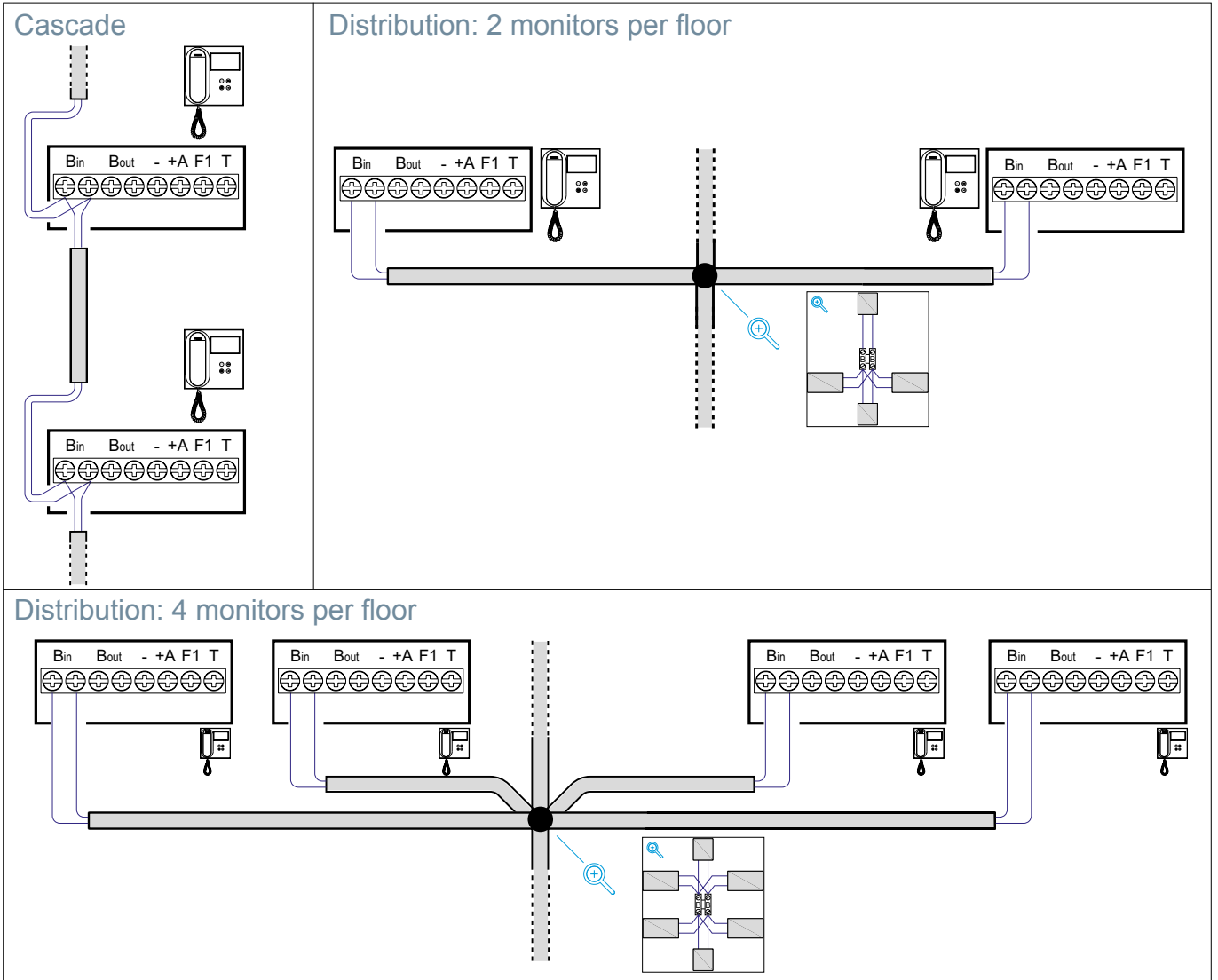

MONITOR PROGRAMMING

Notes:

- Before programming the monitor, the outdoor panel should be set as the master outdoor panel.
- **Configuration as master outdoor panel.** Press the SW1 button 3 times in quick succession. Once 2 seconds have elapsed, a confirmation tone will sound and the master outdoor panel will be activated. Once the programming of the monitors is complete, it is advisable to deactivate the MASTER outdoor panel by pressing button SW1 3 consecutive times.

1. INSTALLATION

Monitor supplied with power for the first time.
 A red LED, blinking slowly, indicates that the monitor is not programmed.
 A fixed LED light indicates that the monitor has been programmed.

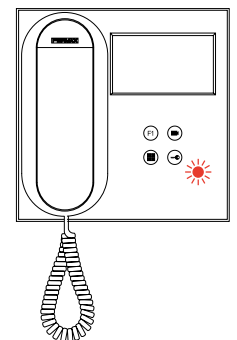

2. ENTERING THE PROGRAMMING MENU

Press the  button to access the “programming menu”.

PROGRAMMING FROM AN OUTDOOR PANEL

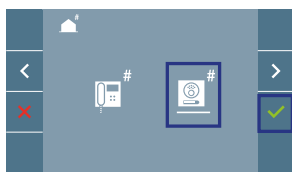

PROGRAMMING MENU

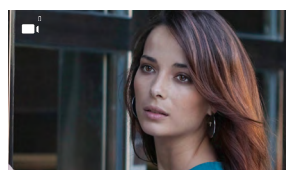
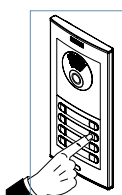

Select the  icon and confirm with  , (a “beep” will be heard in the monitor).

Press the corresponding pushbutton from the outdoor panel (call code for that monitor). A different ring tone will sound, confirming the programming of the monitor. After a few seconds, the monitor will return to standby mode.

PROGRAMMING FROM THE MONITOR (only one person is required to complete the programming process)

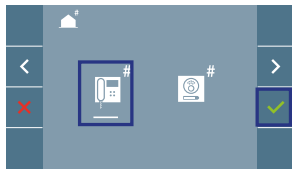

Select the **>** icon and confirm with .



Each time that **+** is pressed, the number increases (starting from 1) and the arrow **<** is used for scrolling.

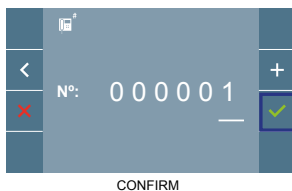

The white cursor indicates the entry position of the digit. Confirm with to complete the process.

3. MONITOR SETTINGS

VIDEO SETTINGS

When there is an image on the monitor after pressing the button, (or if a call is received without picking up the receiver), press the key to display the video settings.

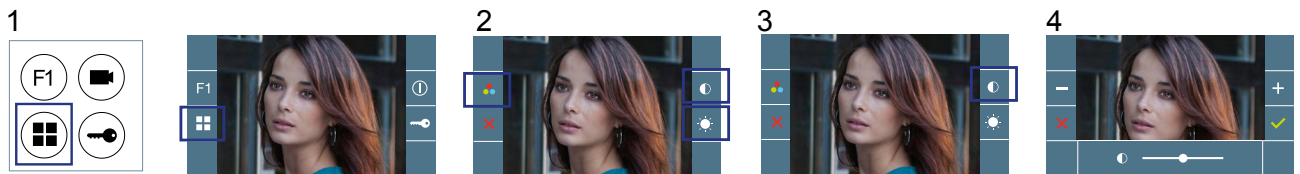

Select the settings option and increase and decrease using **+** and **-**.

AUDIO SETTINGS

While the audio channel is open, press the button and the menu for this setting will appear on the screen.

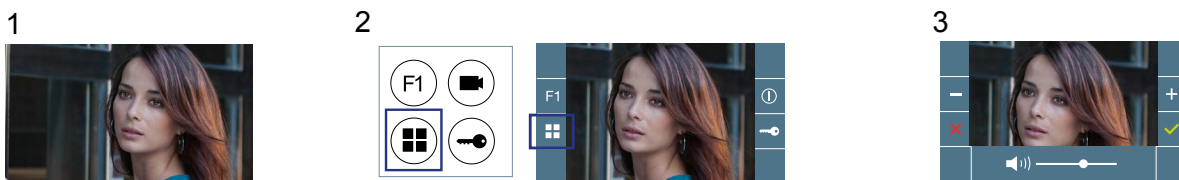

Increase or decrease using **+** and **-**, until obtaining the required regulation.

Note: Maximum conversation time: 90 seconds.

USER SETTINGS

Access User Parameters.

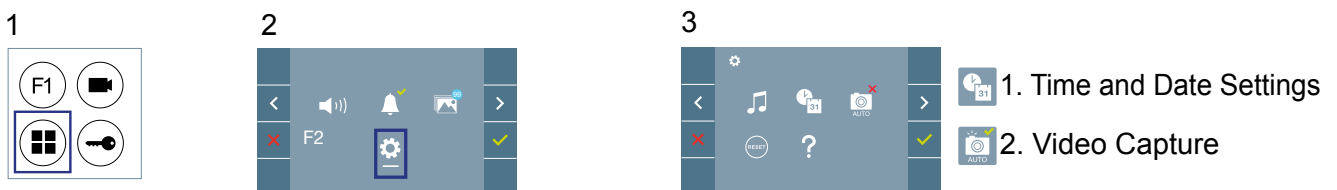

Select the **>** icon and confirm with .

1. DATE AND TIME SETTINGS

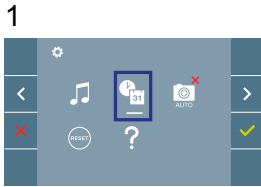

Select the **>** icon and confirm with **✓**.



Use **↓** **↑** to select the date format. Once this has been selected, confirm using **✓**.

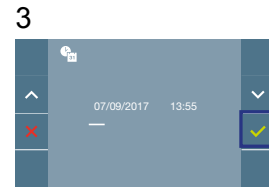

Select the time and date with **↓** **↑** and confirm **✓**. To navigate through the settings **>**.

Non-programmed date: 01/01/2017 (by default). The icon will appear, indicating that the date is not correct (default date). If the power supply is lost, the default date will be restored.

Note: If an image is captured without the date having being programmed, the icon will be displayed.

Icons notifying of a non-programmed date::

User Menu screen

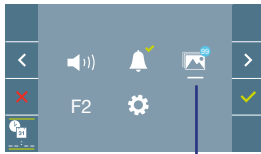
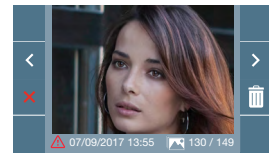

Image display

Communication screen



Image Display screen



2. ACTIVATION/DEACTIVATION OF VIDEO CAPTURE

The monitor can take an automatic picture within 5 seconds of receiving a call from an outdoor panel. According to the European Union legislation about data protection ((EU) 2016/679), the capture of images may be restricted. This feature is deactivated by default in all monitors, although can be activated at your own responsibility.

Furthermore, the legislation may force to place a sign next to door stations, indicating that monitors can capture images. You can download it at <https://www.fermax.com/intl/en/corporate/utilities.html>.

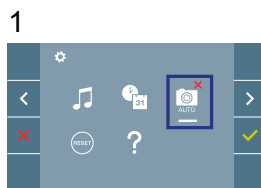

Select the **>** icon and confirm with **✓**.

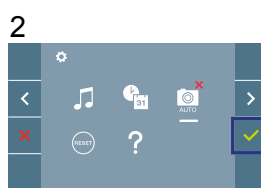

Push **✓** to activate/deactivate the function.

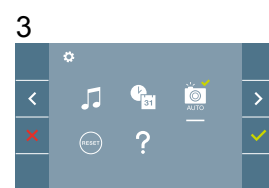

TECHNICAL SPECIFICATIONS

Power supply	18 - 24 Vdc
Standby consumption	VEO: 0,8 W / VEO WiFi: 1,3 W
Maximum consumption	VEO: 5,2 W / VEO WiFi: 6,9 W
OSD screen	TFT 4,3"
6-digit address	000001...999999
Operating temperature	[-5° , +40°C] / [23° , 104°F]
Dimensions	200 x 200 x 46mm - 8" x 8" x 1.8" - (Height x Width x Depth)

FUNCTIONING

1. FUNCTIONING: PAIRING. Call forwarding.

The VEO WIFI DUOX PLUS monitor allows access to new Fermax services, such as call divert, through its own cloud. To use this service, the monitor must first be connected to the Internet through a pairing process. To do this, use the Blue app, which is available on Google Play or the Apple App Store.

Monitor settings. Pairing process.

The monitor pairing process, using the Blue app, can begin once the user has registered and logged in.

The DUOX PLUS monitor is only compatible with 2.4GHz WiFi.

How to connect the monitor to the Internet.



1 Open the application and log in.

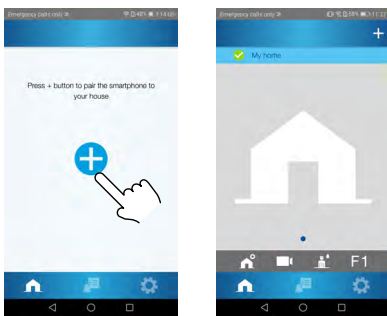

2 Click on the button + in the middle of the default screen, or in the top right if there are already some properties listed.

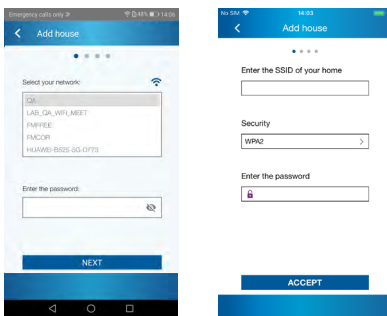

Android

iOS

3 The user will need to select the desired WiFi network to connect the monitor.

Select (if using Android) or enter (if using iOS) the desired SSID (network name), enter the correct password to connect and click NEXT/ACCEPT.

4 The user will then need to open the monitor's connectivity menu:



4a Press the MENU button, to access the User Menu.

4b Relationship between buttons and navigation menu. The white line below the icon shows which function is currently selected.

4c Select the connectivity menu on the monitor.

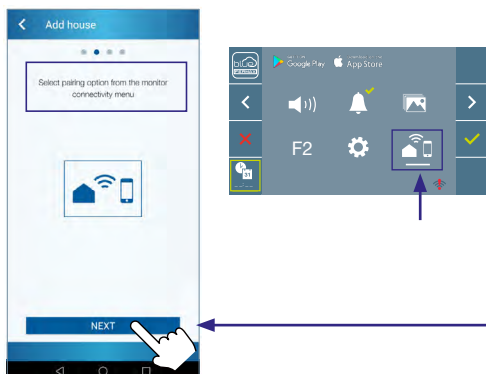
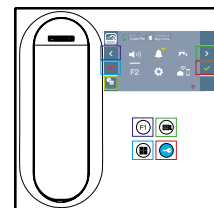

5 Once the connectivity menu is selected, press to access.

Click NEXT when ready.



6 A QR code will show on the monitor screen.

A MAC code is provided on screen in case the WiFi router uses MAC filtering.



7 The application will be ready to scan that code. Point your mobile phone at the QR code on the monitor screen so the code is within the green square on the mobile screen.

8 The application and monitor will begin to synchronize. The white WiFi LED on the monitor will start flashing.

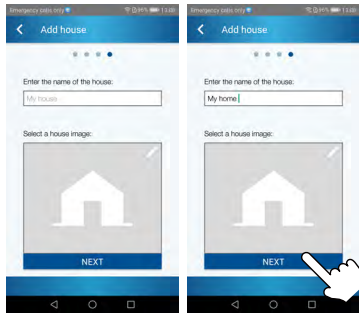
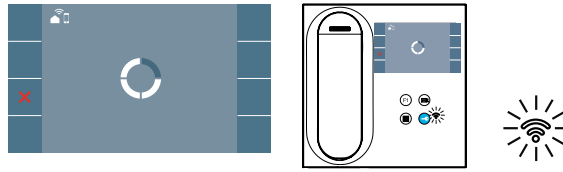

9 The screen to add a property will appear:
 - Name
 - Image (optional)
 Enter data and press NEXT.



11 If the WiFi network and credentials provided are correct, the monitor will connect to the Internet and the process will have been completed successfully.



12 The application will show the new linked house as available and connected (green tick ✓) and the monitor will show that connection was successful. The white WiFi led will stay now stay on.

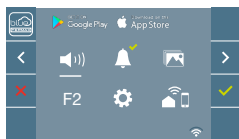
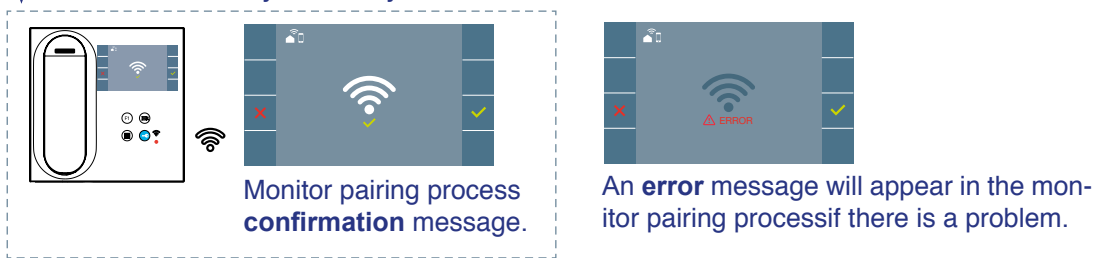

13 Once connected, the WiFi signal strength will appear in the bottom right of the monitor user menu.

WiFi signal strength icons displayed in the menu:

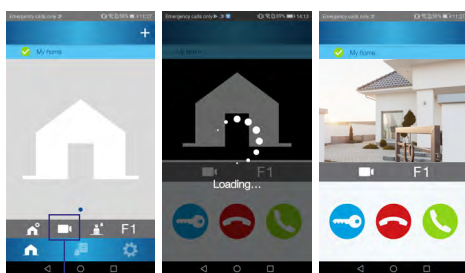

Auto-on

14 To test the call divert function, the user can select auto-on and see whether it connects to the outdoor panel, (as long as it is not in use).



7.3 VEO TELEPHONE

CONTROL BUTTONS

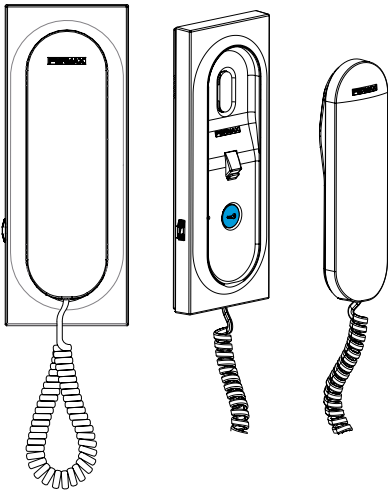

Lock release button / Call to the concierge:

- While in conversation with the outdoor panel, pushing this button will activate the lock release.
- In standby mode, pressing this button will make a call to the concierge (if applicable).

Auto switch-on when picking up the telephone. (Must be programmed).

This feature is possible with the outdoor panel of the same block, if the outdoor panel is in standby mode and programmed as "0" and if there is a conversation channel available.

*Note: - If a call is received from another panel, when the conversation has been completed, for 15 seconds, **auto switch-on** will happen with that panel.*

CONNECTIONS

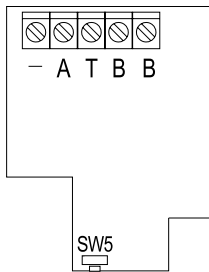

Telephone Connectors:

B,B: Power supply to telephones, data and audio.

T, -: Apartment door call button (P1).

A+, -: Option of connection with the following devices:

- Call extender ref. 2040.
- Light and buzzer commander ref. 2438.

SW5: Button to enter programming.

Cascade

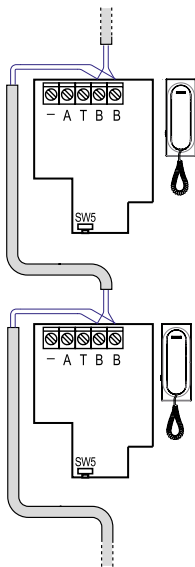

Distribution: 2 telephones per floor

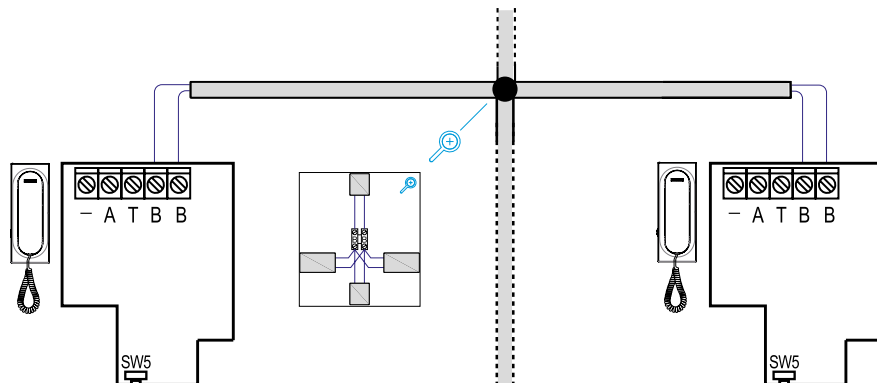

Distribution: 4 telephones per floor

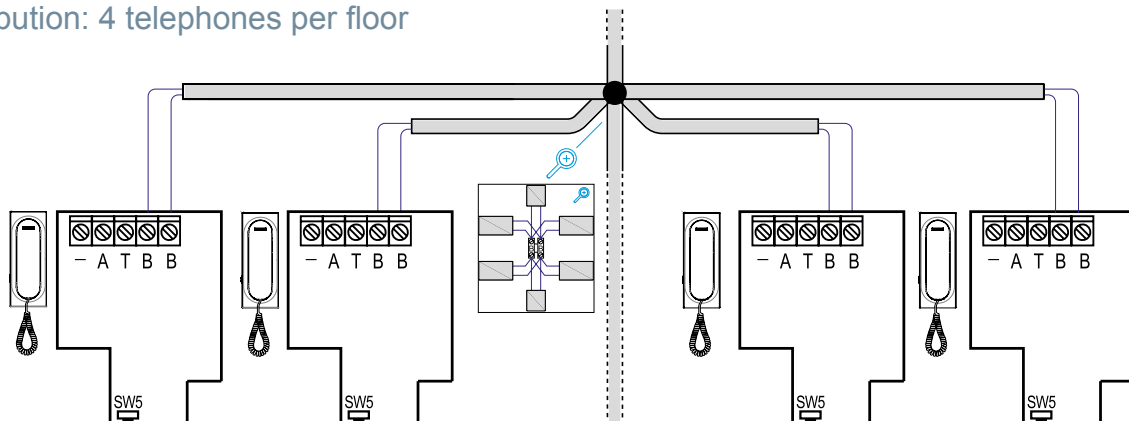

TELEPHONE PROGRAMMING

Notes:

- Before programming the telephone, the outdoor panel should be set as the master outdoor panel.
- **Configuration as master outdoor panel.** Press button SW1 3 times in quick succession. Once 2 seconds have elapsed, a confirmation tone will sound and the master outdoor panel will be activated. Once the programming of the monitors is complete, it is advisable to deactivate the MASTER outdoor panel by pressing button SW1 3 consecutive times.
- If there is a guard unit this should be in night mode.

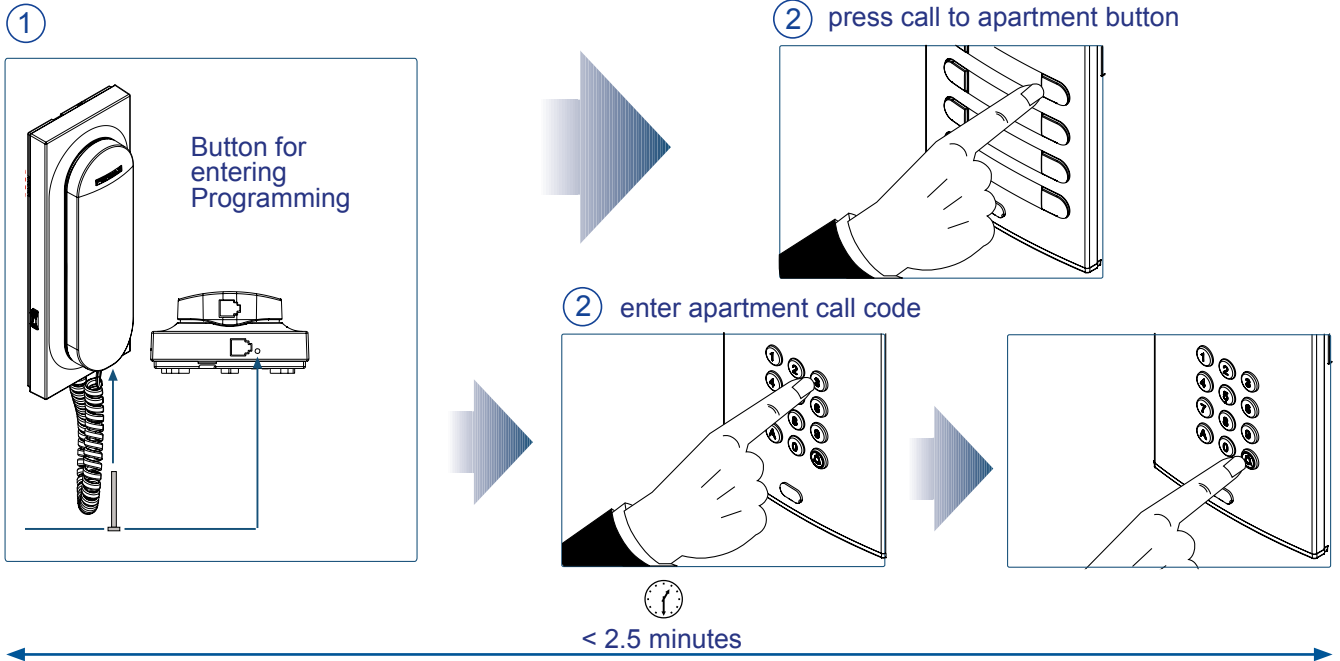

1. With the telephone connected and hung up, press the programming button until a “beep” sounds. On releasing the programming button, the “enter programming mode” will sound (long beep).

As an additional option, the telephone handset can be picked up to establish communication with the outdoor panel and inform the operator of which apartment it is found in. The door release is also permitted.

2. Press the call button for the apartment or enter the corresponding code. The programming confirmation will result (if the telephone is hung up).

Check that the telephone has been programmed by making a call.

Note: The telephone will not function if it has not been programmed.

USER SETTINGS

CALL RING TONE SELECTION (MELODIES)

The telephone can be used to select a separate melody for the calls received from outdoor panels and for the calls made from guard units.

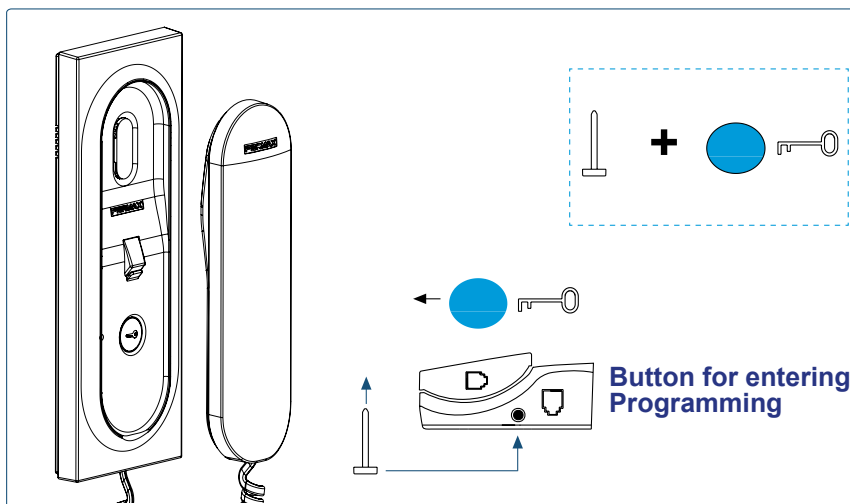

- 1. Selection of call ring tone for outdoor panel:** With the telephone hung up and on standby mode, press the programming button of the telephone (a “beep” will sound) and without releasing this button, press the lock release button. The current melody will be heard. Release the programming button. Each time the lock release button is pressed again, the next melody will sound.
- 2. Selection of call ring tone for guard unit:** While in the outdoor panel call ring tone selection menu, pressing and holding the lock release button for 5 seconds will play the current melody for calls from the guard unit. Each time the lock release button is pressed again, the next melody will sound.

Note: The call ring tone selection process is exited after 10 seconds of inactivity (with the last melody reproduced being stored in the memory). This exit is confirmed by: Single beep: from the outdoor panel and double beep: from the guard unit.

TECHNICAL SPECIFICATIONS

Power supply	18 - 24 Vdc
Standby consumption	0,3 W
Maximum consumption	3,5 W
Maximum conversation time	90 seconds
6-digit address	000001...999999
Operating temperature	[-5° , +40°C] / [23° , 104°F]
Choice of call melodies	
Number of conversation channels (audio-only installation):	2 per bus



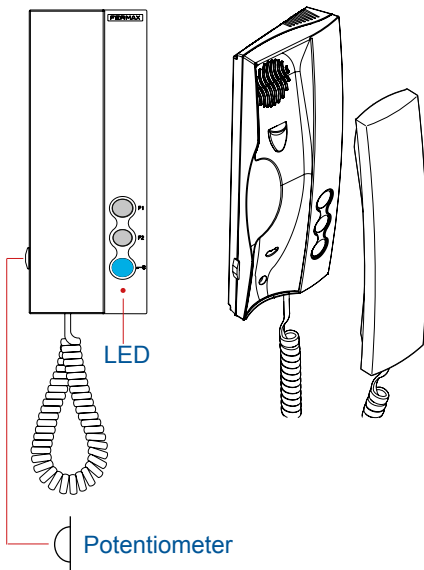

7.4 LOFT EXTRA TELEPHONE

CONTROL BUTTONS / LEDS



- 
Lock release button / Call to the concierge:
 - While in conversation with the outdoor panel, pushing this button will activate the lock release.
 - With the telephone hanging up (in standby mode), pressing this button will make a call to the concierge (if applicable).
- Auto switch-on when picking up the telephone. (Must be programmed).**

This feature is possible with the outdoor panel of the same block, if the outdoor panel is in standby mode and programmed as “0” and if there is a conversation channel available.

*Note: If a call is received from another panel, when the conversation has been completed, for 15 seconds, **auto switch-on** will happen with that panel.*
-  **F1** Auxiliary function (check with your installer).
-  **F2**
- 
Ring tone volume setting.

On standby: At the MINIMUM, call disconnection (Do Not Disturb Mode, red LED lit).

Conversation in progress: Upstream audio setting.
-  **Red LED:**
 - Switched on. Do Not Disturb mode has been activated.
 - Intermittent. Non-programmed telephone (*standby*).
 - Shut down. Programmed telephone (*standby*), or without power source.

CONNECTIONS

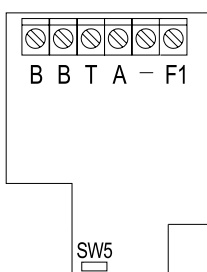

Telephone Connectors:

B,B: Power supply to telephones, data and audio.

T, -: Apartment door call button (P1).

A+, -: Option of connection with the following devices:

- Call extender ref. 2040.
- Light and buzzer commander ref. 2438.

F1: Button for additional functions. Provides a negative upon activation.

SW5: Button to enter programming.

Cascade

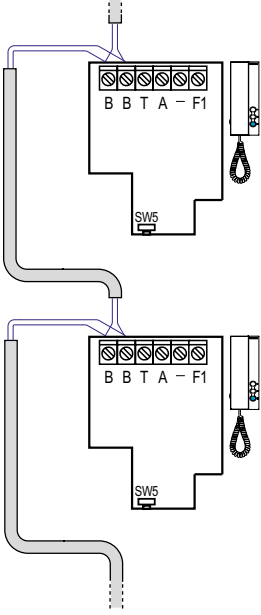

Distribution. 2 telephones per floor

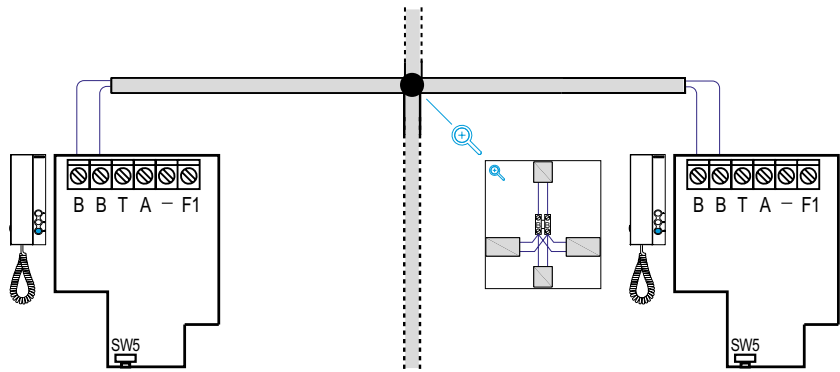

Distribution. 4 telephones per floor

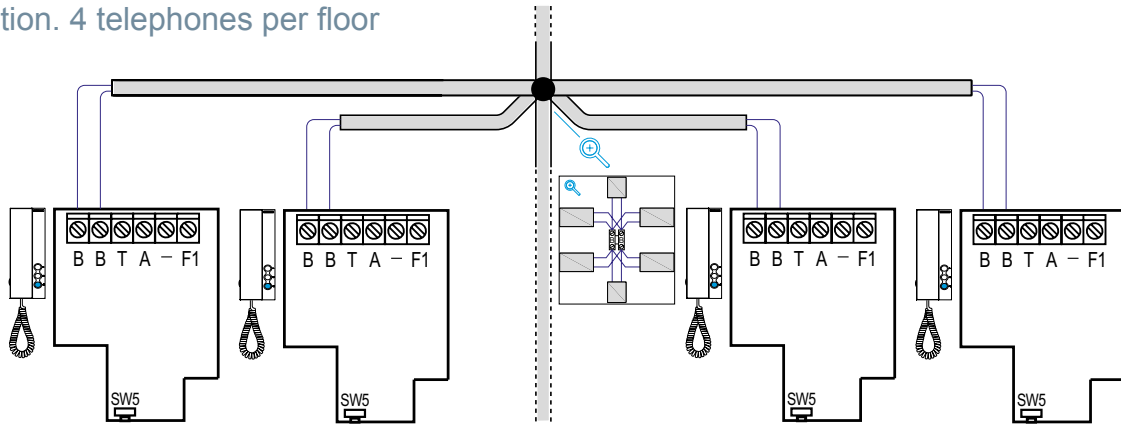

TELEPHONE PROGRAMMING

Notes:

- Before programming the telephone, the outdoor panel should be set as the master outdoor panel.
- **Configuration as master outdoor panel.** Press button SW1 3 times in quick succession. Once 2 seconds have elapsed, a confirmation tone will sound and the master outdoor panel will be activated. Once the programming of the monitors is complete, it is advisable to deactivate the MASTER outdoor panel by pressing button SW1 3 consecutive times.
- If there is a guard unit this should be in night mode.

①

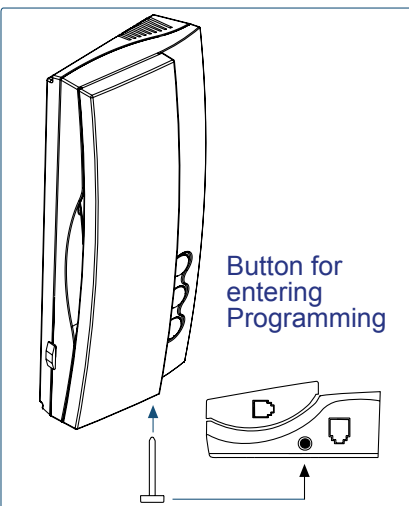

② press call to apartment button

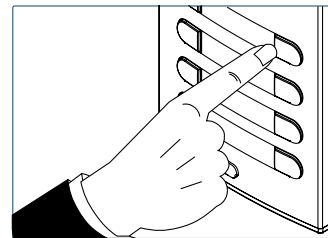

② enter apartment call code

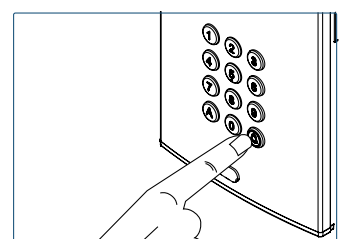
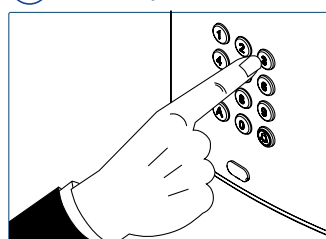

< 2.5 minutes

1. With the telephone connected and hung up, press the programming button until a “beep” sounds. On releasing the programming button, the “enter programming mode” will sound (long beep).
As an additional option, the telephone handset can be picked up to establish communication with the outdoor panel and inform the operator of which apartment it is found in. The door release is also permitted.
2. Press the call button for the apartment or enter the corresponding code. The programming confirmation will result (if the telephone is hung up).

Check that the telephone has been programmed by making a call.

Note: The telephone will not function if it has not been programmed.

USER SETTINGS

CALL RING TONE SELECTION (MELODIES)

The telephone can be used to select a separate melody for the calls received from outdoor panels and for the calls made from guard units.

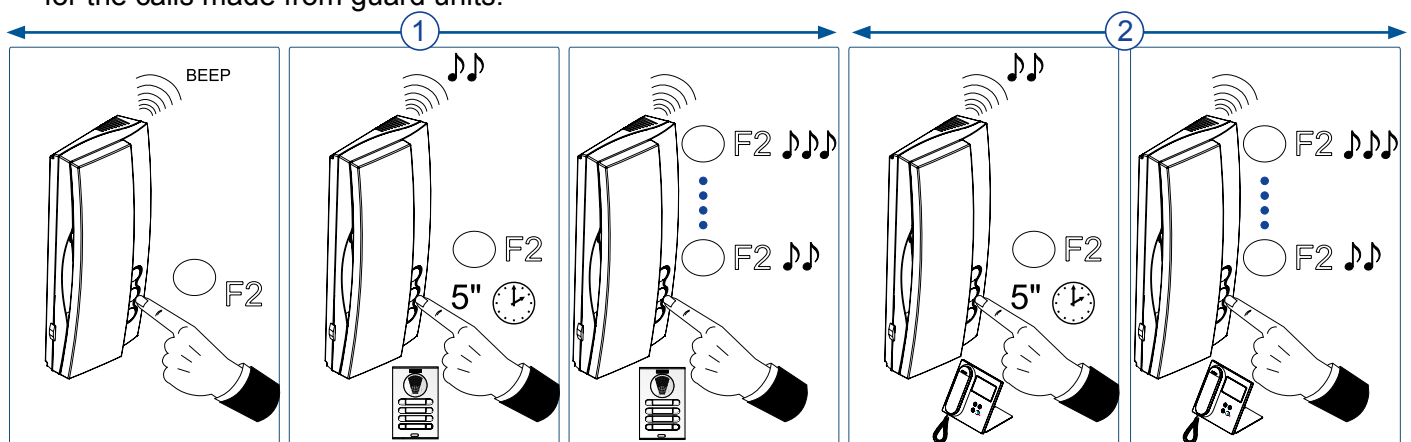

1. **Selection of call ring tone for outdoor panel:** With the telephone hung up and on standby mode, press button F2 (a “beep” will sound). After keeping the button pressed down for 5 seconds, the current melody will be heard. With each new short pulse on F2, the next melody will sound. After reaching melody 5, the cycle begins again with melody 1. The last melody to play will be the one that is selected.
2. **Selection of call ring tone for guard unit:** While in the outdoor panel melody selection menu, holding down F2 for 5 seconds will play the current call melody for calls from the guard unit. With each new short pulse on F2, the next melody will sound. After reaching melody 5, the cycle begins again with melody 1.

Notes:

- The call ring tone selection process is exited after 10 seconds of inactivity (with the last melody reproduced being stored in the memory). This exit is confirmed by: Single “beep”: from the outdoor panel and double “beep”: from the guard unit.
- While in the guard unit melody menu, pressing down F2 for 5 seconds will leave the guard unit melody menu and return to standby mode, storing the selected melody. This exit is confirmed by a double “beep”.

TECHNICAL SPECIFICATIONS

Power supply	18 - 24 Vdc
Standby consumption	0,29 W
Maximum consumption	3,3 W
Maximum conversation time	90 seconds
6-digit address	000001...999999
Operating temperature	[-5° , +40°C] / [23° , 104°F]
Choice of call melodies	
Number of conversation channels (audio-only installation):	2 per bus

7.5 iLOFT TELEPHONE

CONTROL BUTTONS / LEDS

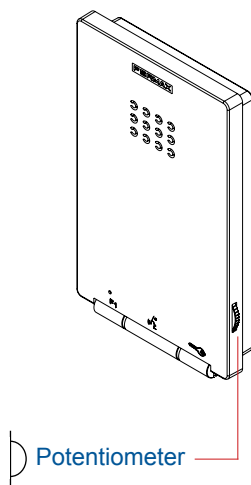
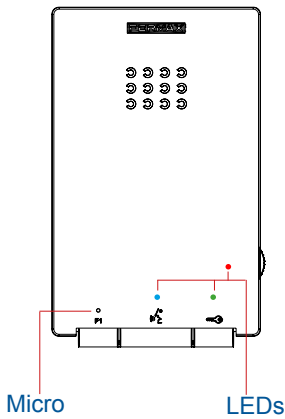

Lock release button / Call to the concierge:

- While in conversation with the outdoor panel (audio activated), pushing this button will activate the lock release.
- On receiving the call (non-active audio). If audio communication is not established, there are 30 seconds in which to complete the release process.
- With the telephone hanging up (in standby mode), pressing this button will make a call to the concierge (if applicable).



Audio Activation, Hang-Up and Auto Switch-On Buttons:

- When receiving a call, there is a 30-second interval in which to answer. The red LED light shuts down during this time, indicating a pending call.
- Audio activation: When you receive a call press this button to speak with the visitor. The audio channel is opened and operation is in hands-free mode (by default). The blue LED will remain lit indicating the conversation with the outdoor panel.
- Hung up: Press to end the conversation, or the conversation will end after 90 seconds.
- Auto switch-on: In standby mode, press and release this button, (the blue LED will light up).

This feature is possible with the outdoor panel of the same block, if the outdoor panel is in standby mode and programmed as "0" and if there is a conversation channel available.

*Note: If a call is received from another panel, when the conversation has been completed, for 15 seconds, **auto switch-on** will happen with that panel.*

F1

Auxiliary function (check with your installer).



Ring tone volume setting.

On standby: At the MINIMUM, call disconnection (Do Not Disturb Mode, red LED blinking).

Conversation in progress: Upstream audio setting.

● Red LED:

Switched on. Programmed telephone (*standby*).

Intermittent fast blinking. Non-programmed telephone (*standby*).

Intermittent slow blinking. Indicates that the Do Not Disturb feature is enabled.

Switched off. Telephone indicating a pending call, or a lack of any power supply.

● Blue LED:

Switched on. Conversation in hands-free audio mode.

On/Intermittent. Conversation in simplex audio mode

● Green LED: According to configuration.

CONNECTIONS

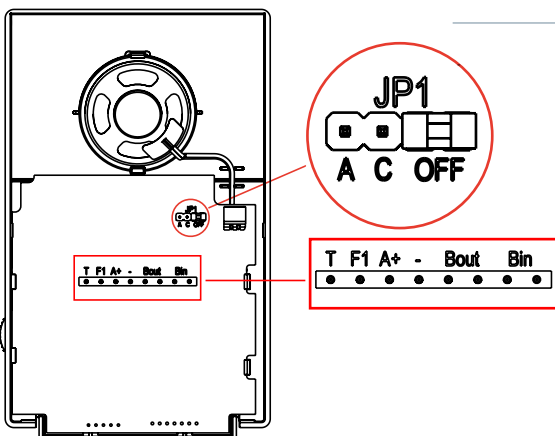

Telephone Connectors:

B,B: Power supply to telephones, data and audio.

T, -: Apartment door call button (P1).

A+, -: Option of connection with the following devices:

- Call extender ref. 2040.
- Light and buzzer commander ref. 2438.

F1: Additional function. Provides a negative upon activation.

JP1: Integrated line adapter bridge

- Right: Without line adaptation: OFF, (by default).
- Centre: Adaptation type C.
- Left: Adaptation type A.

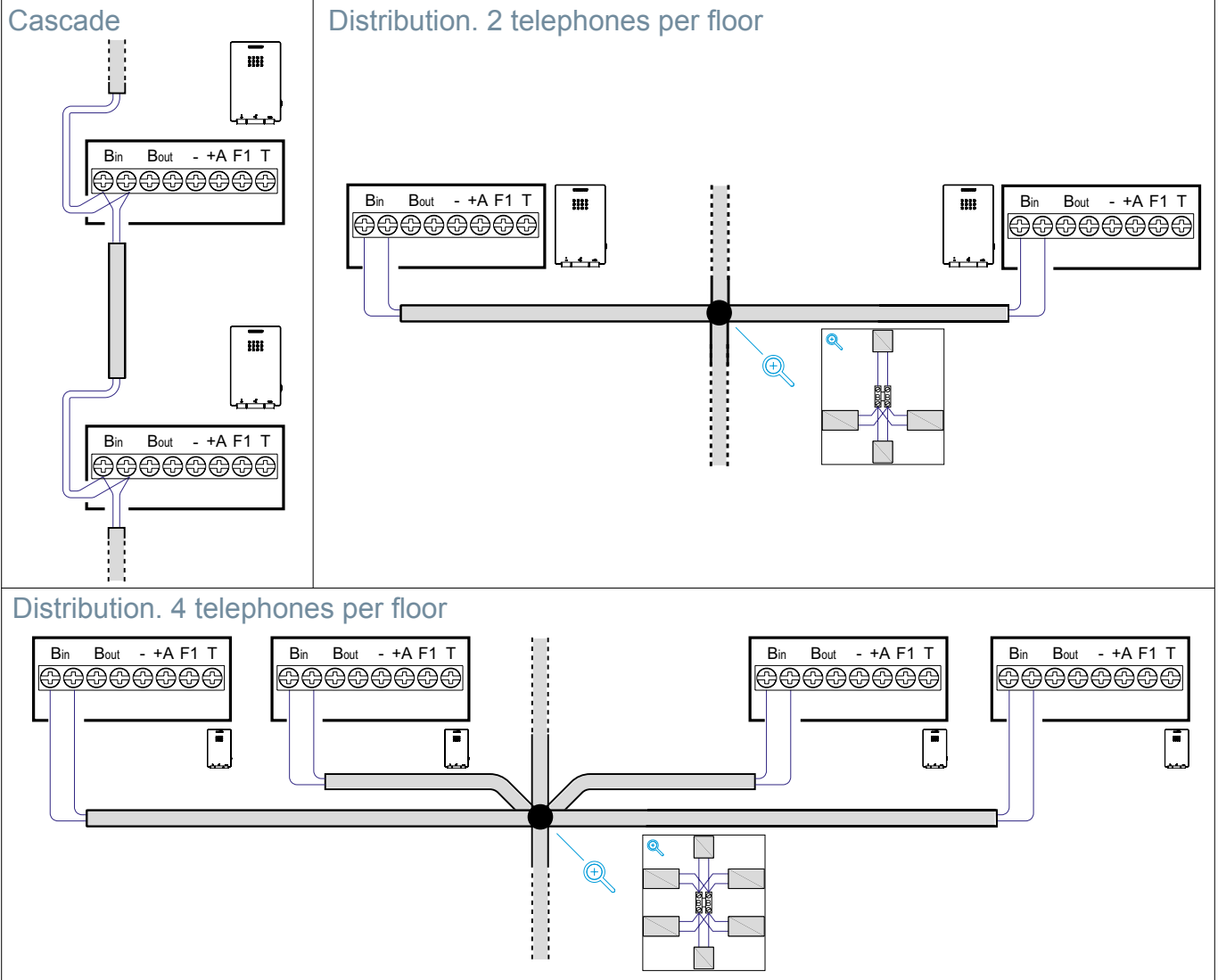

TELEPHONE PROGRAMMING

Notes:

- Before programming the telephone, the outdoor panel should be set as the master outdoor panel.
- **Configuration as master outdoor panel.** Press button SW1 3 times in quick succession. Once 2 seconds have elapsed, a confirmation tone will sound and the master outdoor panel will be activated. Once the programming of the monitors is complete, it is advisable to deactivate the MASTER outdoor panel by pressing button SW1 3 consecutive times.
- If there is a guard unit this should be in night mode.

With the telephone connected and in standby mode:

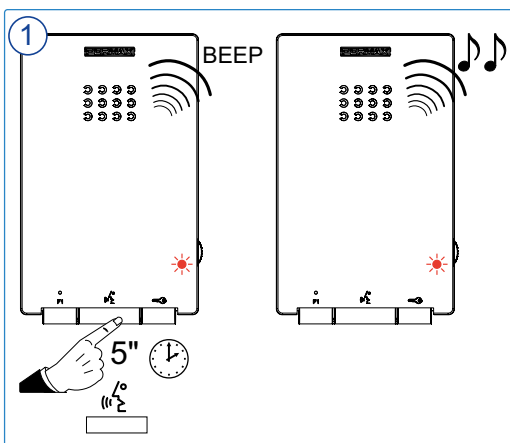

1. Start from the “**Melody selection from outdoor panel**” configuration menu.

Press the SW1 button for 5” until a “beep” sounds. Release the button and the current outdoor panel melody will sound. (Non-programmed telephone, red LED blinking rapidly). In this status:

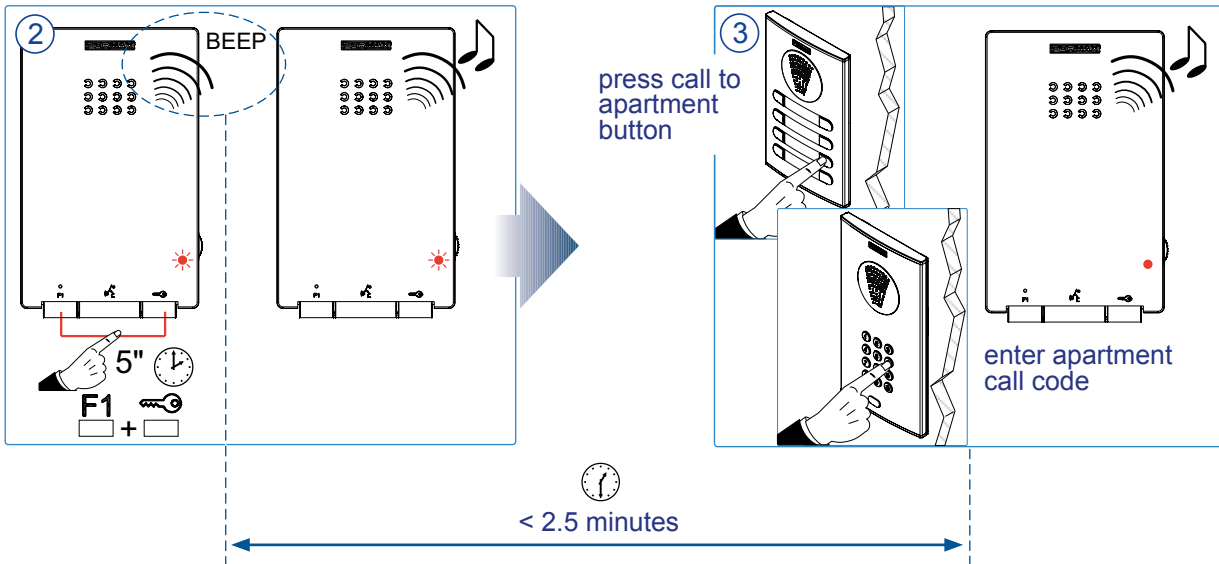

2. Press the F1 button and the button simultaneously for 5" until a "BEEP" confirmation sounds (a beep confirming entering programming mode). Release.

3. Press the call code/button from the outdoor panel to the apartment. A confirmation tone will sound in the telephone. The telephone is programmed (fixed red LED).

Note: The period between the sounding of the "beep" confirming entry into the telephone programming mode and the call being made from the outdoor panel to program the telephone address must be less than 2 and a half minutes.

USER SETTINGS

CALL RING TONE SELECTION (MELODIES)

The telephone can be used to select a separate melody for the calls received from outdoor panels and for the calls made from guard units.

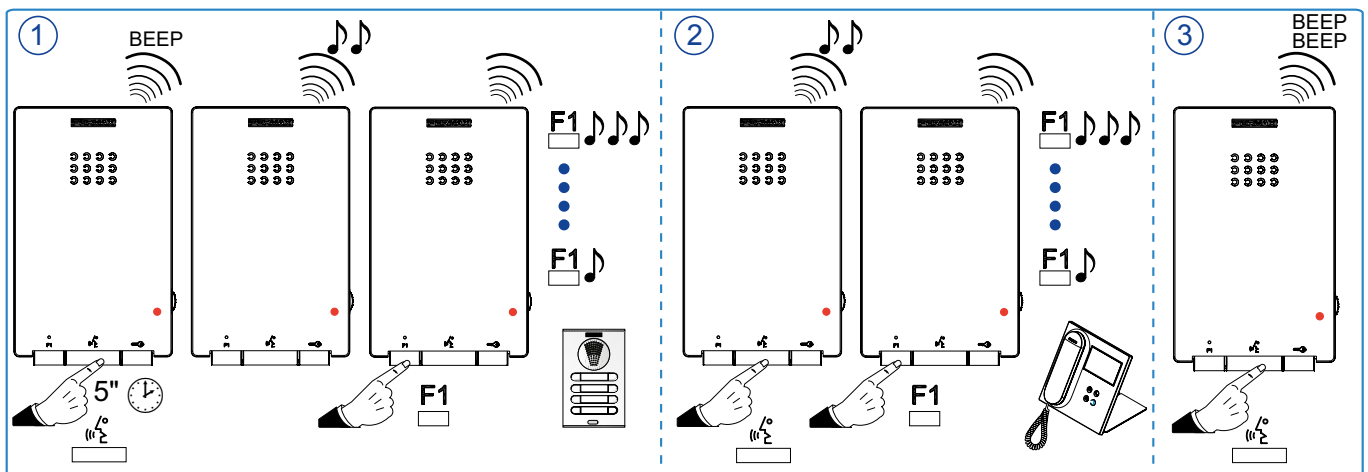

1. **Selection of call ring tone for outdoor panel:** With the telephone hung up and on standby mode, press the button for 5" until a "beep" sounds. Release the button and the current outdoor call melody will sound. Press the F1 button to select the melody (circular sequence). The last melody to play will be the one that is selected.

2. **Selection of call ring tone for guard unit:** While in "selection of melody from the outdoor panel" mode, press the button to select "melody configuration from the guard unit". The current guard unit melody will sound. Press the F1 button to select the melody (circular sequence). The last melody to play will be the one that is selected.

3. **Exit melody selection (standby mode):** While selecting melodies from the guard unit, making a short pulse on the button will exit the guard unit melody selection menu, returning to standby mode and storing the selected memory. This exit is confirmed by a double "beep".

Note: In addition to this, the call ring tone selection process is exited after 10 seconds of inactivity (with the last melody reproduced being stored in the memory). This exit is confirmed by: Single "beep": from the outdoor panel and double "beep": from the guard unit.

TECHNICAL SPECIFICATIONS

Power supply	18 - 24 Vdc
Standby consumption + LED	0,4 W
Maximum consumption	3,6 W
Maximum conversation time	90 seconds
6-digit address	000001...999999
Operating temperature	[-5° , +40°C] / [23° , 104°F]
Dimensions	146 x 90 x 20mm (Height x Width x Depth)
Choice of call melodies	
Number of conversation channels (audio-only installation):	2 per bus
Conversation modes	
hands-free	by default
simplex	push to talk: push button  to talk, release to listen

7.6 LOFT BASIC PLUS TELEPHONE

CONTROL BUTTONS

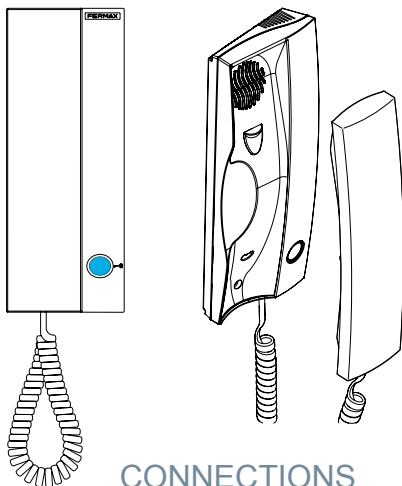

Lock release button / Call to the concierge:

- While in conversation with the outdoor panel, pushing this button will activate the lock release.
- With the telephone hanging up (in standby mode), pressing this button will make a call to the concierge (if applicable).

Auto switch-on when picking up the telephone. (Must be programmed).

This feature is possible with the outdoor panel of the same block, if the outdoor panel is in standby mode and programmed as "0" and if there is a conversation channel available.

CONNECTIONS

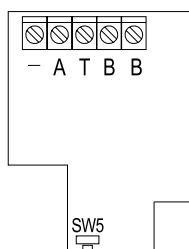

Telephone Connectors:

B,B: Power supply to telephones, data and audio.

T, -: Apartment door call button (P1).

A+, -: Option of connection with the following devices:

- Call extender ref. 2040.
- Light and buzzer commander ref. 2438.

SW5: Button to enter programming.

Cascade

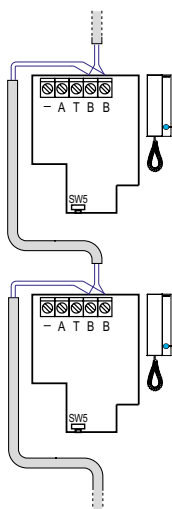

Distribution: 4 telephones per floor

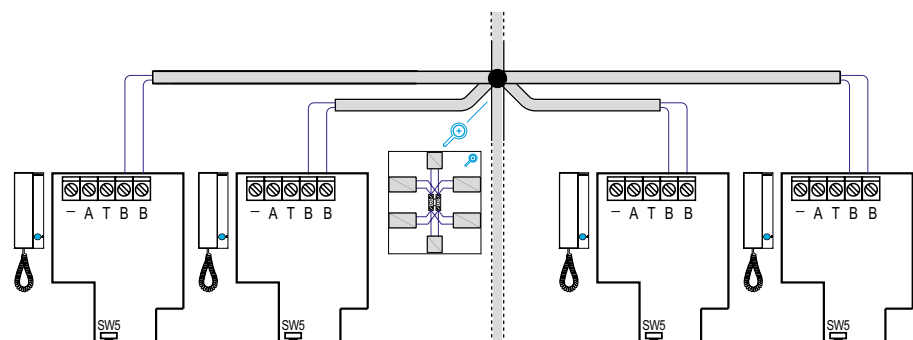

TELEPHONE PROGRAMMING

Notes:

- Before programming the telephone, the outdoor panel should be set as the master outdoor panel.
- **Configuration as master outdoor panel.** Press button SW1 3 times in quick succession. Once 2 seconds have elapsed, a confirmation tone will sound and the master outdoor panel will be activated. Once the programming of the monitors is complete, it is advisable to deactivate the MASTER outdoor panel by pressing button SW1 3 consecutive times.
- If there is a guard unit this should be in night mode.

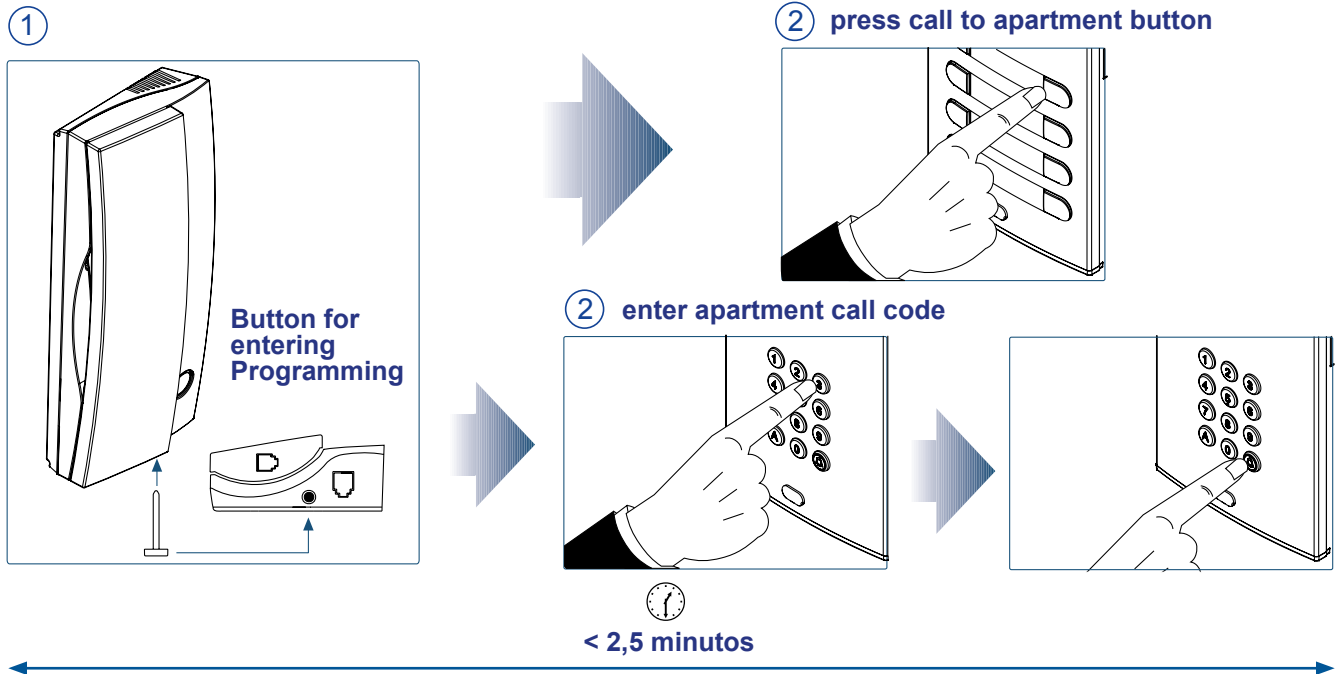

1. With the telephone connected and hung up, press the programming button until a “beep” sounds. On releasing the programming button, the “enter programming mode” will sound (long beep).

As an additional option, the telephone handset can be picked up to establish communication with the outdoor panel and inform the operator of which apartment it is found in. The door release is also permitted.

2. Press the call button for the apartment or enter the corresponding code. The programming confirmation will result (if the telephone is hung up).

Check that the telephone has been programmed by making a call.

Note: The telephone will not function if it has not been programmed.

TECHNICAL SPECIFICATIONS

Power supply	18 - 24 Vdc
Standby consumption	0,29 W
Maximum consumption	3,3 W
Maximum conversation time	90 segundos
6-digit address	000001...999999
Operating temperature	[-5° , +40°C] / [23° , 104°F]
Choice of call melodies	
Number of conversation channels (audio-only installation):	2 por bus



8. DUOX PLUS ACCESSORIES

8.1 DUOX PLUS RELAY

The DUOX PLUS Relay provides DUOX PLUS installations with a potential-free relay, with several configurable operating and activation modes:

- Activation of the relay through commands generated by the apartment terminals, outdoor panels or guard units.
- External activation through pushbuttons, additional external switches and so on.

The relay is supplied with power from the DUOX PLUS bus and can be installed in any part of the bus. It is possible to install one or more relays, per apartment, block or installation. Programming is via the pushbuttons of the relay itself. There is no need for additional programming elements, although configuration with the DUOX PLUS programmer is also possible.

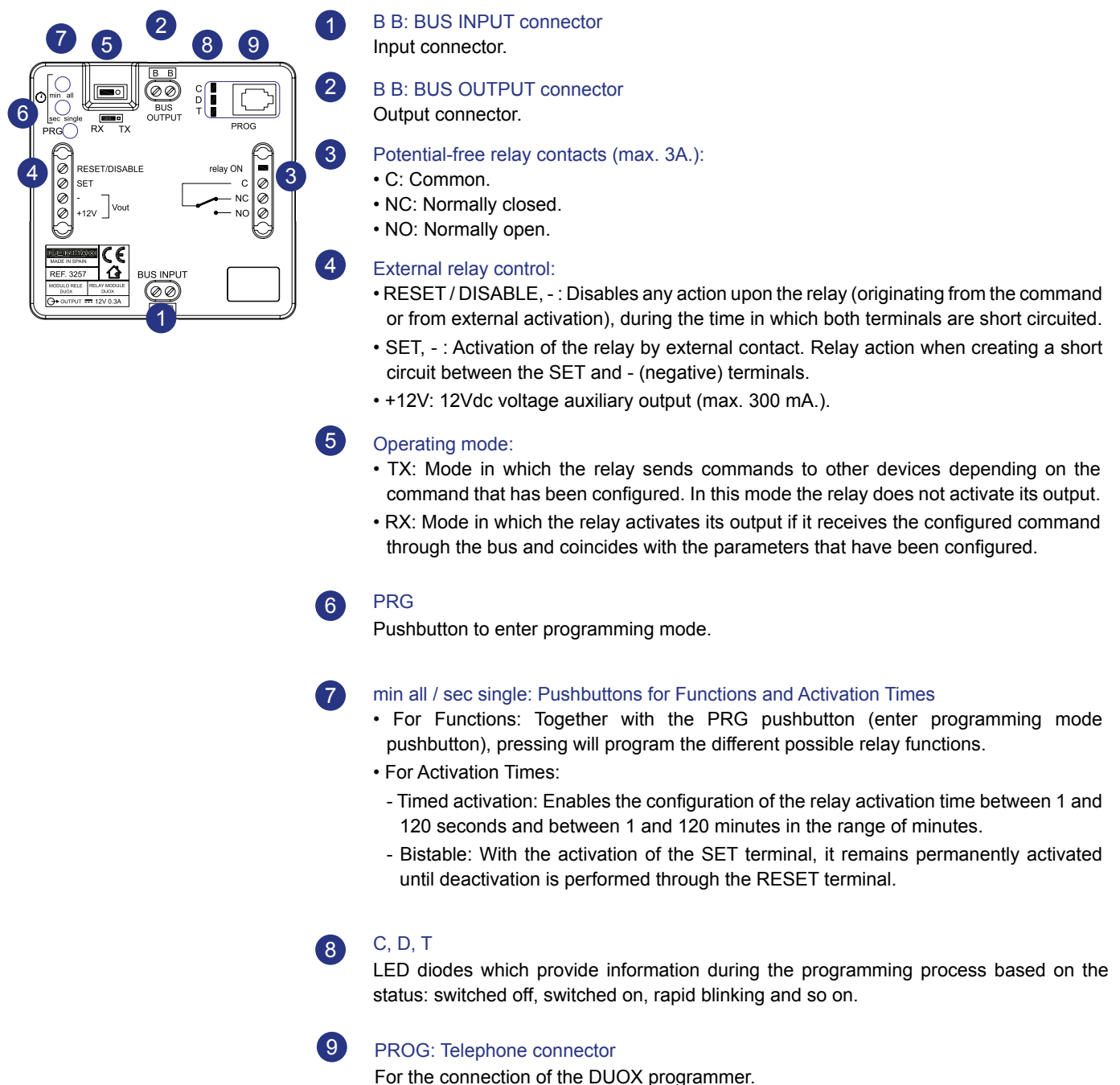

The relay has several **configurable operating modes**:

1- RX Mode. The relay **activates its output** when it receives the configured programmed command.

The usual functions normally include:

- Activation of the relay when effectuating the release.
- Activation of the relay when generating a call from the outdoor panel to the apartment.
- Activation of the relay when a call to the concierge is received.
- Activation of the relay when effectuating auto switch-on.
- Activation or deactivation of the relay upon activating relay F1.
- Activation or deactivation of the relay upon activating relay F2.
- Activation or deactivation of the relay activated/deactivated from "SET" and "-".

2- TX Mode. In this mode the relay **does not activate its output**. Other functions may be performed from a pushbutton connected between "SET" and "-".

- Lock release function upon receiving a call.
- Lock release function to a configured outdoor panel.
- Call to guard unit function.
- Activation or deactivation of relay F1 function.
- Activation or deactivation of relay F2 function.
- Activation or deactivation of remote relay function.

Other configurations:

- Configuration of activation times through integrated pushbuttons.
- Parameter reset.

These functions are outlined in detail in the [Manual code 97822 DUOX Advanced Relay Manual](#), available online.

TECHNICAL SPECIFICATIONS

Power supply	18 - 24 Vdc
Standby consumption	1,24 W
Maximum consumption	4,4 W
+12V	12 Vdc voltage auxiliary output (max. 300mA.)
Potential-free relay contacts.	
C	Common
NC	Normally closed
NO	Normally open
Operating temperature	[0° , +40°C] / [32° , 104°F]
Maximum relay contact current	3 A.
Maximum relay tension voltage	300VAC or 60VDC.

8.2 DUOX PLUS LIFT CONTROL UNIT

The DUOX PLUS lift control unit is a device used to provide a lift control service for the DUOX PLUS installation. This allows visitors to access only the floor corresponding to the flat that has opened the door for them. It is an interface between DUOX PLUS and MDS. The MDS Central Unit is responsible for the lift control function. It connects to the DUOX PLUS bus, to the MDS Panel bus and to the MDS Decoder bus. The lift control function must be programmed in the MDS Central Unit using WINCOM+ software.

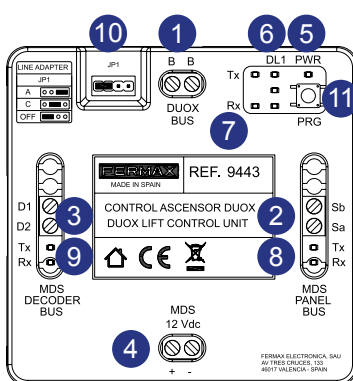
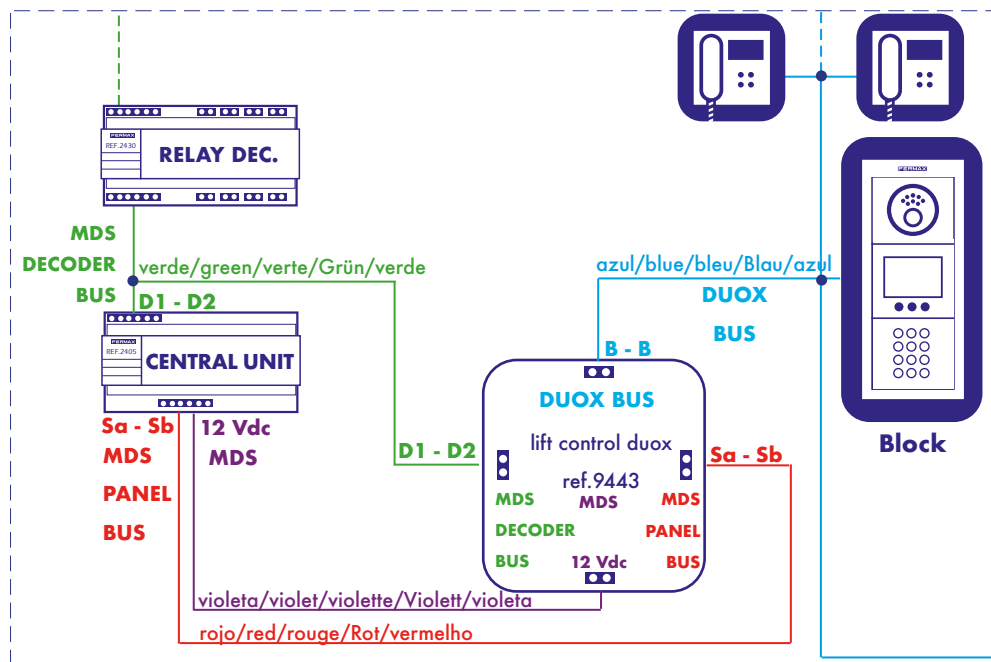

- 1 B B: DUOX BUS connector
DUOX Bus: Power and data.
- 2 Sa Sb: MDS bus data connector for panels
Sa: MDS bus data for panels.
Sb: MDS bus data for panels.
- 3 D1 D2: MDS bus data connector for decoders
D1: MDS bus data for decoders.
D2: MDS bus data for decoders.
- 4 + -: MDS bus power
+: MDS bus power (+12VDC).
-: Mass of the MDS bus.
- 5 LED PWR
LED indicating power and used in programming.
- 6 LED DL1
LED indicating that a call has been established.
- 7 DUOX bus LEDs TX / RX
LEDs to signal the transmission and reception of data through the DUOX bus.
- 8 Panels bus LEDs TX / RX (MDS PANEL BUS)
LEDs to signal the transmission and reception of data through the MDS panel bus.
- 9 Decoder bus LEDs TX / RX (MDS DECODER BUS)
LEDs to signal the transmission and reception of data through the MDS decoder bus.
- 10 JP1: Line adaptation bridge
o To the right: Type A adaptation.
o In the centre: Type C adaptation.
o To the left: OFF. Without line adaptation (by default).
- 11 PRG: Programming Button. Do not press this button if your block is block 0.
As a default, the interface is programmed as Interior Block 0.

TECHNICAL CHARACTERISTICS

Power	18 - 24 VDC (obtained from the DUOX bus) 12 VDC (uses MDS power)
Standby Consumption	0,5 W
Active Consumption	0,54 W
Operating Temperature	-5°C to +40°C // 23°F to 104°F
Humidity	90% without condensation

8.3 DUOX PLUS CAMERA INTERFACE

The Duox Plus camera interface is a device that allows you to integrate CCTV analog composite video cameras in a Duox Plus installation. It transforms the analog composite video signal (1 Vpp, 75 ohm) from a camera (PAL / NTSC) into a Duox Plus which connects directly to the Duox Plus bus. Each camera must be powered externally with an additional power supply .The interface is powered directly by the Duox Plus bus

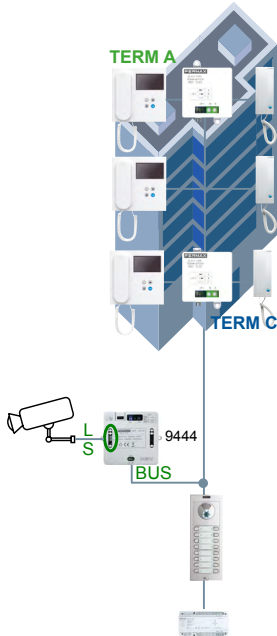

CONNECTIONS AND LED INDICATORS

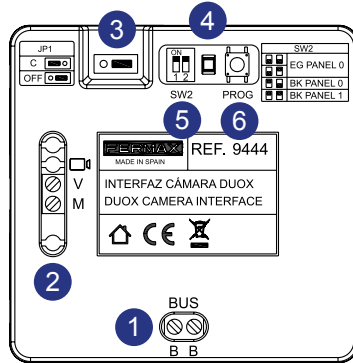

- 1 B B: BUS Connector
DUOX PLUS Bus: Power supply and data.
- 2 L S: Camera's video connection
L: Live.
S: Shielded.
- 3 JP1: Integrated line adaptor
• Right: Without line adaptation: OFF, (default).
• Left: Type C Adaptation.
- 4 LED Programming
Programming mode informative LED.
Blinking (1 second) in programming mode.

5 SW2: Camera Settings.

Microswitch 1.

OFF: Camera 0 for General Entrance.

ON: Camera for Interior Block (the camera number must be programmed with dipswitch 2).

Microswitch 2.

No function in the General Entrance (may be ON / OFF).

OFF: Camera 0 of Interior Block.

ON: Camera 1 of Interior Block.

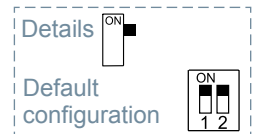

Notes:

- By default SW2 is configured as Interior Block - Camera 1.
- The block number configuration is done via the programming button. By default Interior Block 0.

TECHNICAL FEATURES

Power	24 Vdc
Standby Consumption	100 mA (max.)
Active Consumption	125 mA (max.)
Operating Temperature	-5°C to +40°C // 23°F to 104°F
Humidity	5% - 95%

9. DUOX PLUS INSTALLATIONS

9.1 PRIOR CONSIDERATIONS REGARDING WIRING AND DUOX PLUS CONSUMPTION

DUOX is characterised by its level of flexibility in terms of the use of different cable types. In replacement works, it functions with existing wiring from previous door entry and video door entry installations. Some of the cables supported by DUOX PLUS include:

- Parallel
- UTP
- 5-wire cables
- 4+N installations

For optimum operation, it is advisable to use a 2x1mm² parallel cable (Ref. 5925).

Minimum cable section in DUOX 0.2mm² (UTP).

In terms of wiring, it is best to avoid:

- Unipolar cables, loose wires (electrical installation cables) and conductors of varying length.
- Changes to the type of cable or section throughout the installation.
- Doubled cables (attaching 2 cables to expand a section), in distribution installations.

Notes:

- Cables can be doubled in cascade installations.
- Using a cable with a larger section than the recommended section does not guarantee an improved system operation.

CONSUMPTION TABLES Maximum number of terminals per power supply set ref.4825.

FLOOR DISTRIBUTION

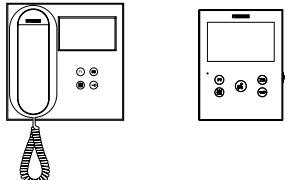
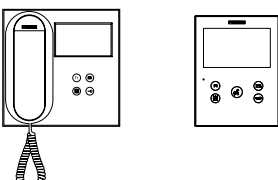
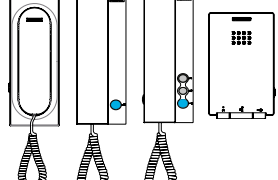
Device	VEO/VEO XS Monitors 	VEO/VEO XS WiFi Monitors 	Telephone 
Sección cable			
1.0 mm ²	40	28	80
0.5 mm ²	40	24	80
0.2 mm ² (UTP)	36	20	72

CASCADE

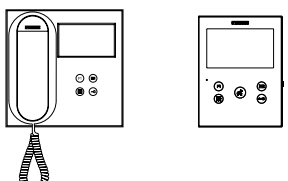
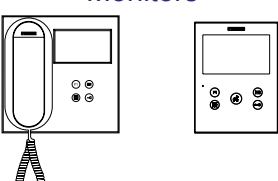
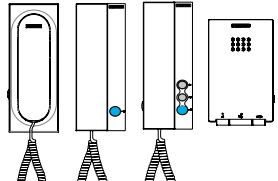
Device	VEO/VEO XS Monitors 	VEO/VEO XS WiFi Monitors 	Telephone 
Sección cable			
1.0 mm ²	40	26	65
0.5 mm ²	32	20	45
0.2 mm ² (UTP)	18	12	25

If the power source with reference 4840 is used, the number of terminals in the tables will be reduced by 6 units.

9.2 BASIC VIDEO INSTALLATIONS (Monitors) AND MIXED INSTALLATIONS (Monitors + Telephones)

The term “Basic DUOX PLUS Installation” makes reference to installations that can be set up without regenerators.

It is characterised by:

- Including the following devices:
 - Outdoor panel
 - Power supply set
 - Monitors and Telephones.
 - Line adapters
- Including up to 40 apartment terminals distributed in a maximum of 4 risers.
- Distances fall between those in the table that will be displayed below.

TABLE: Maximum distance from the outdoor panel to the first fork: D

		CASCADE	2/4 Terminals x Storey	6 Terminals x Storey	8 Terminals x Storey
D	1 Riser	55 metres	55 metres	55 metres	55 metres
	2 Risers	50 metres	50 metres	35 metres	-
	3 Risers	25 metres	25 metres	25 metres	-
	4 Risers	25 metres	-	-	-

Note: In CASCADE the distance will be the distance from the outdoor panel to the first monitor.

In 1 riser, the maximum distance in derivation between the riser and the furthest terminal is 30 metres. For more risers, it is 20 metres.

9.2.1 EXAMPLE OF A DUOX PLUS BASIC INSTALLATION. 1 RISER

TABLE: Maximum distance from the outdoor panel to the first fork: D

		CASCADE	2/4 Terminals x Storey	6 Terminals x Storey	8 Terminals x Storey
D	1 Riser	55 metres	55 metres	55 metres	55 metres

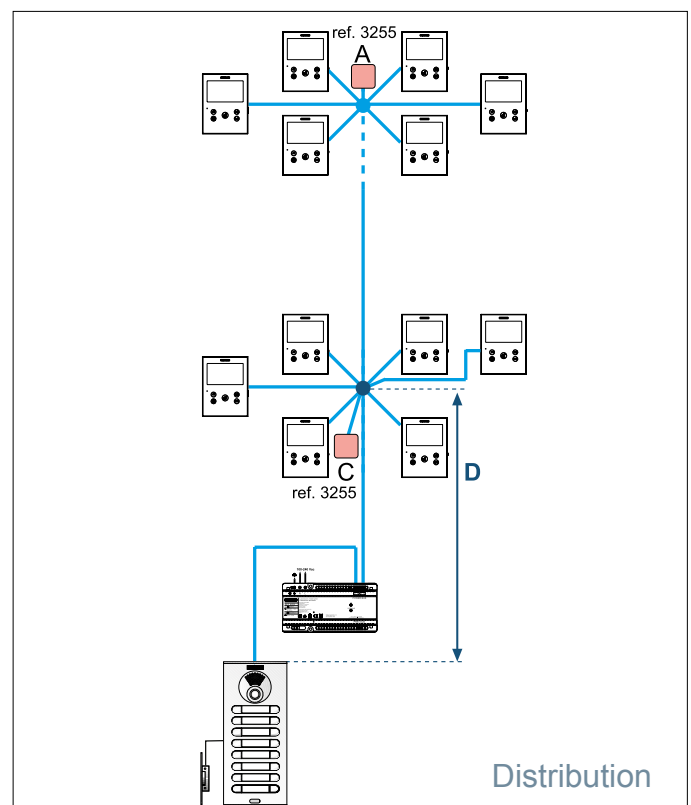
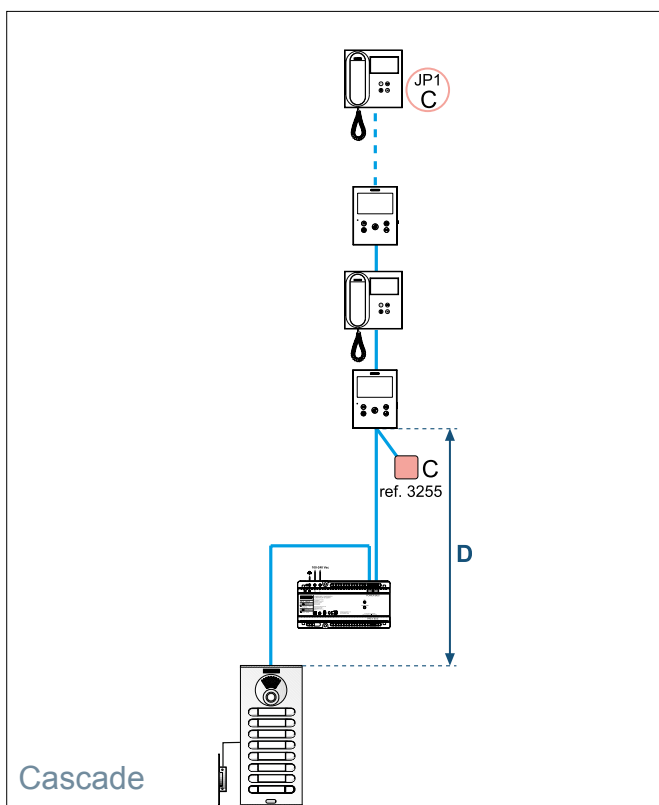

9.2.2 EXAMPLE OF A DUOX PLUS BASIC INSTALLATION. 2 RISERS

TABLE: Maximum distance from the outdoor panel to the first fork: **D**

	CASCADE	2 Terminals x Storey	4 Terminals x Storey	6 Terminals x Storey
D 2 Risers	50 metres	50 metres	50 metres	35 metres

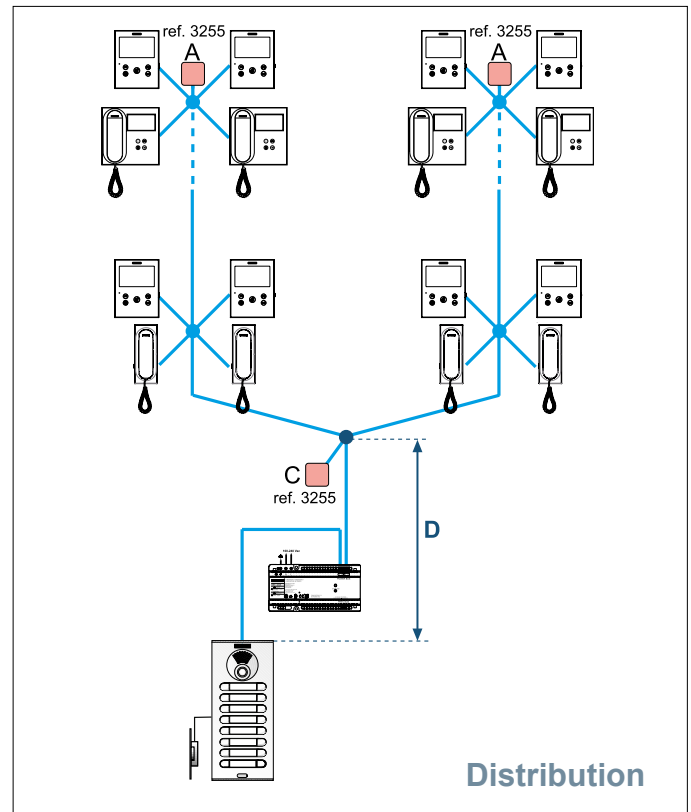
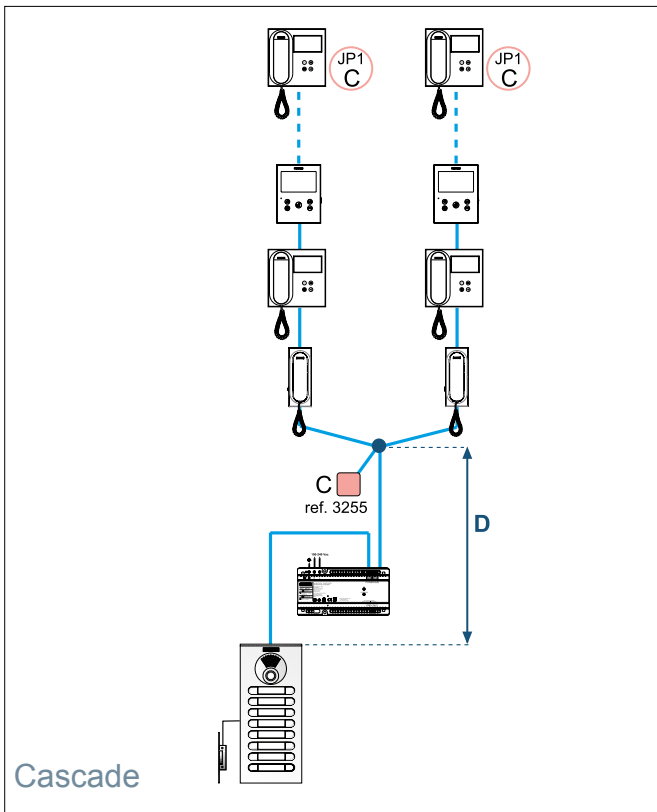

9.2.3 EXAMPLE OF A DUOX PLUS BASIC INSTALLATION. 3 RISERS

TABLE: Maximum distance from the outdoor panel to the first fork: **D**

	CASCADE	2 Terminals x Storey	4 Terminals x Storey	6 Terminals x Storey
D 3 Risers	25 metres	25 metres	25 metres	25 metres

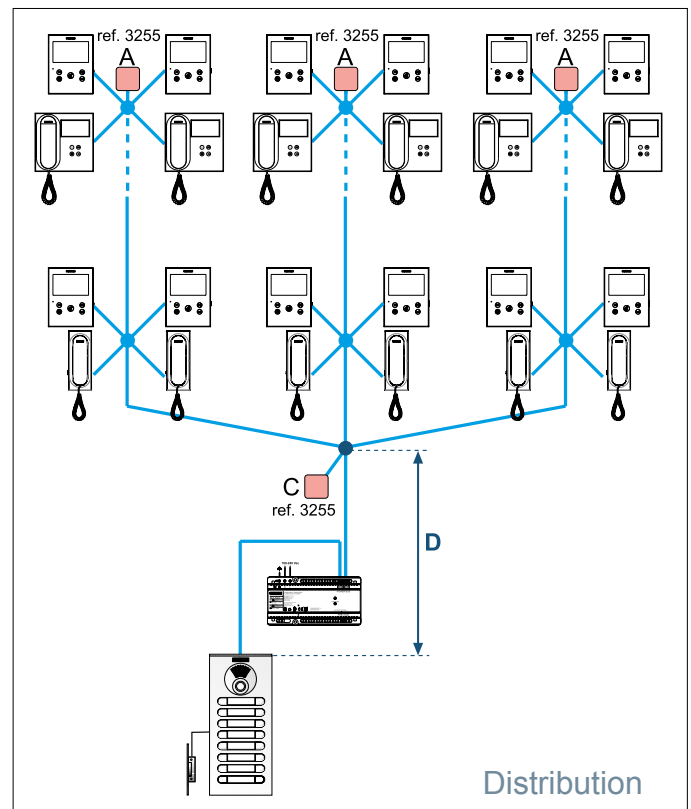
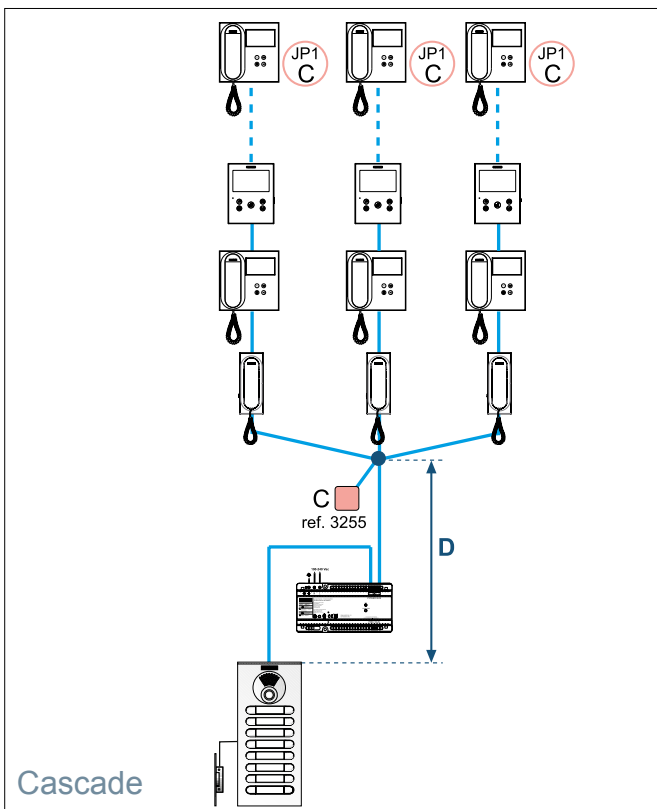

9.2.4 EXAMPLE OF A DUOX PLUS BASIC INSTALLATION. 4 RISERS

TABLE: Maximum distance from the outdoor panel to the first fork: **D**

	CASCADE	2 Terminals x Storey	4 Terminals x Storey	6 Terminals x Storey
D 4 Risers	25 metres	-	-	-

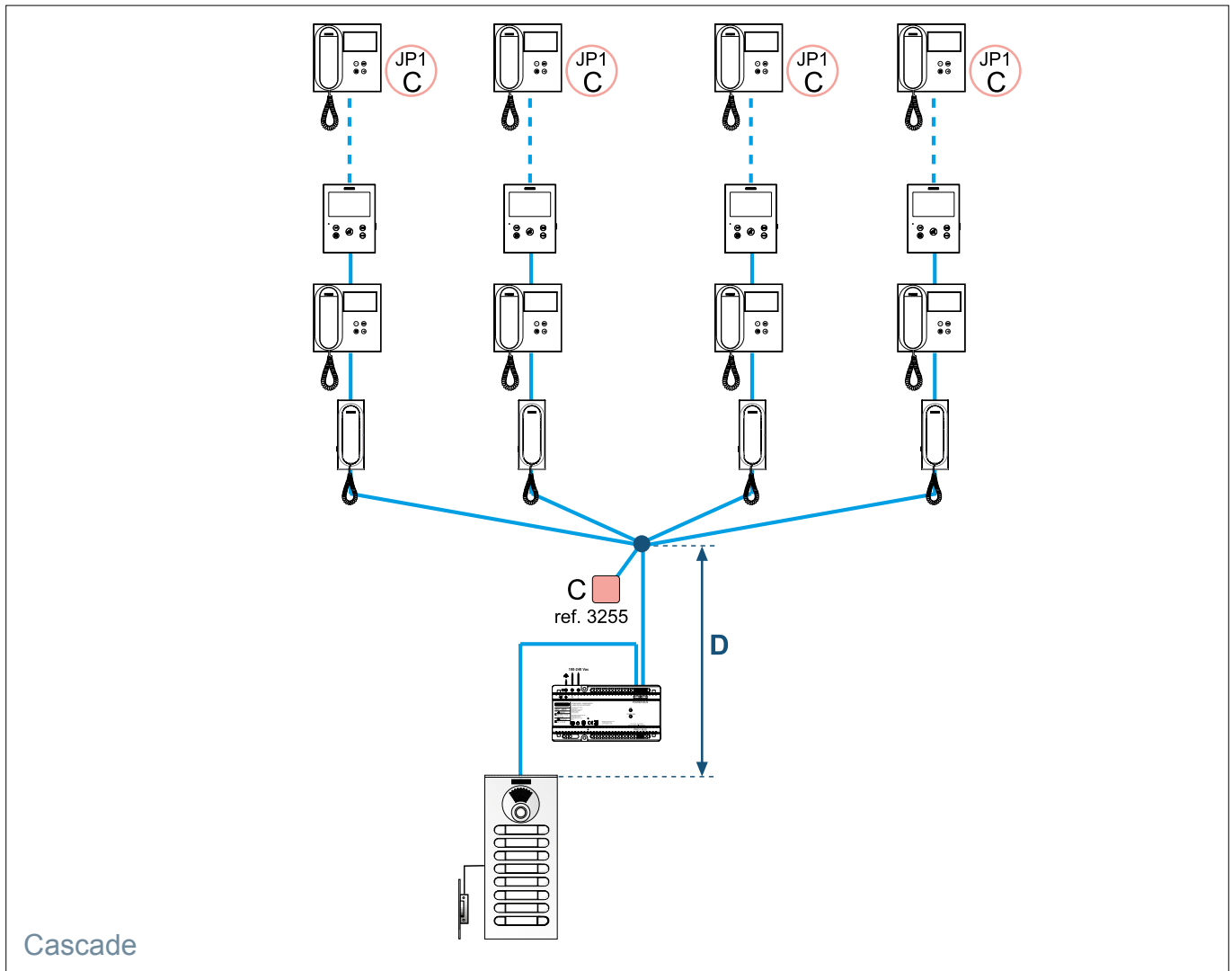

9.3 BASIC AUDIO INSTALLATION (Telephones)

The term “Basic DUOX Audio Installation” makes reference to the entirety of the installation that can be set up without regenerators.

It is characterised by:

- Including the following devices:
 - Outdoor panel
 - Power supply set
 - Telephones.
 - Line adapters
- Including up to 200 telephones distributed in a maximum of 4 risers with up to 4 terminals per storey.
- The maximum distance between the outdoor panel and the first fork: **D**, must not exceed 30 metres.

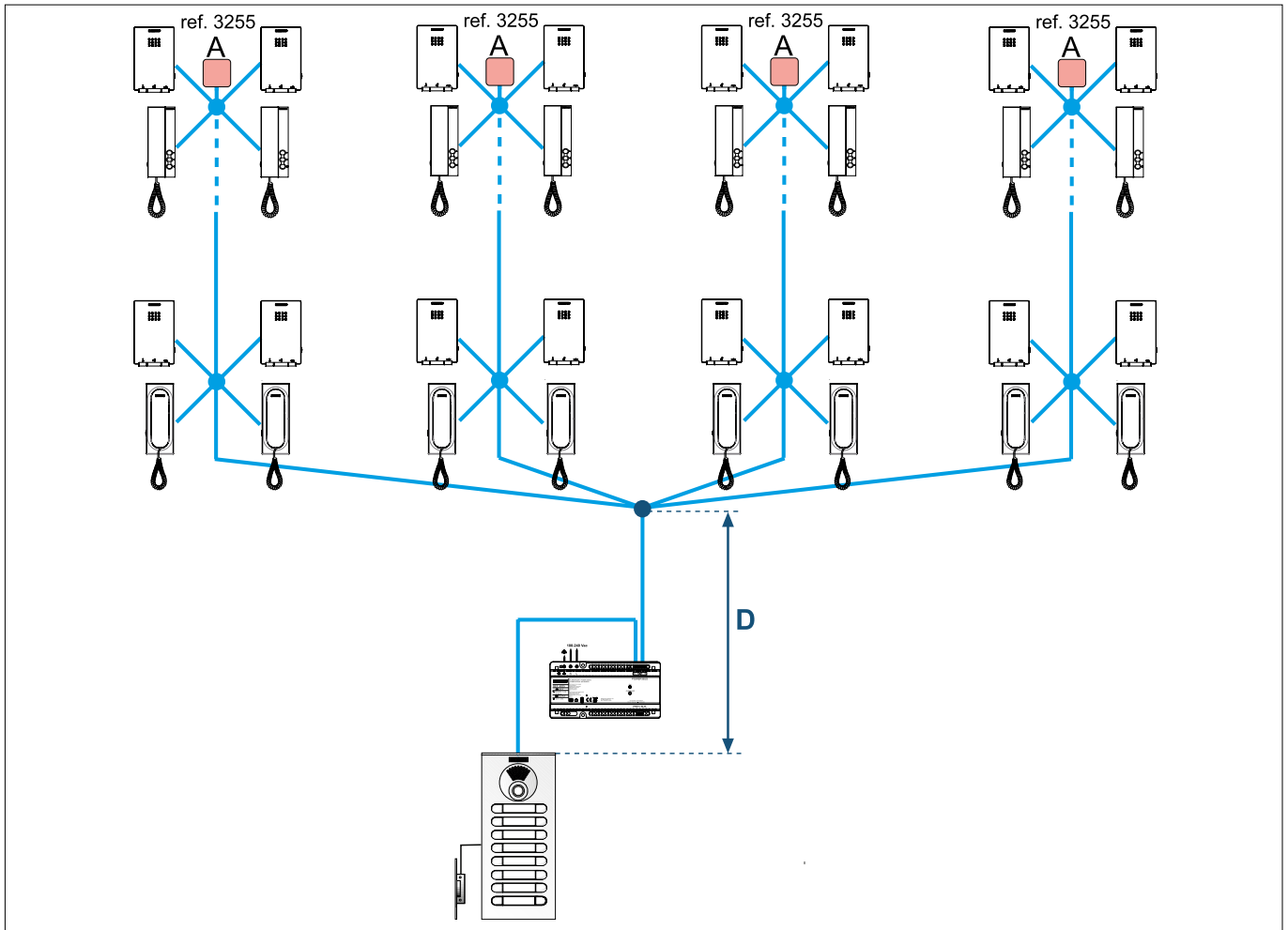

9.4 EXTENDED INSTALLATION

An “Extended Installation” refers to any installation that exceeds the technical specifications indicated in a Basic Installation.

In order to set up these installations it is necessary to use regenerators.

Possible uses and applications:

- **Increasing the distance between the outdoor panel and the first fork.**

See the Distances Table / Cables and Examples section.

TABLE: Distance / Cable section (between the outdoor panel and the first bifurcation): **D**

		Cable section		
		2 x 1.0 mm ²	2 x 0.5 mm ²	2 x 0.2 mm ²
D (distance)	Regenerator WITHOUT a power supply set in the outdoor panel	250 metres	200 metres	80 metres
	Regenerator WITH a power supply set in the outdoor panel	500 metres	500 metres	500 metres

Example 1: Regenerator **WITHOUT** a power supply set in the outdoor panel

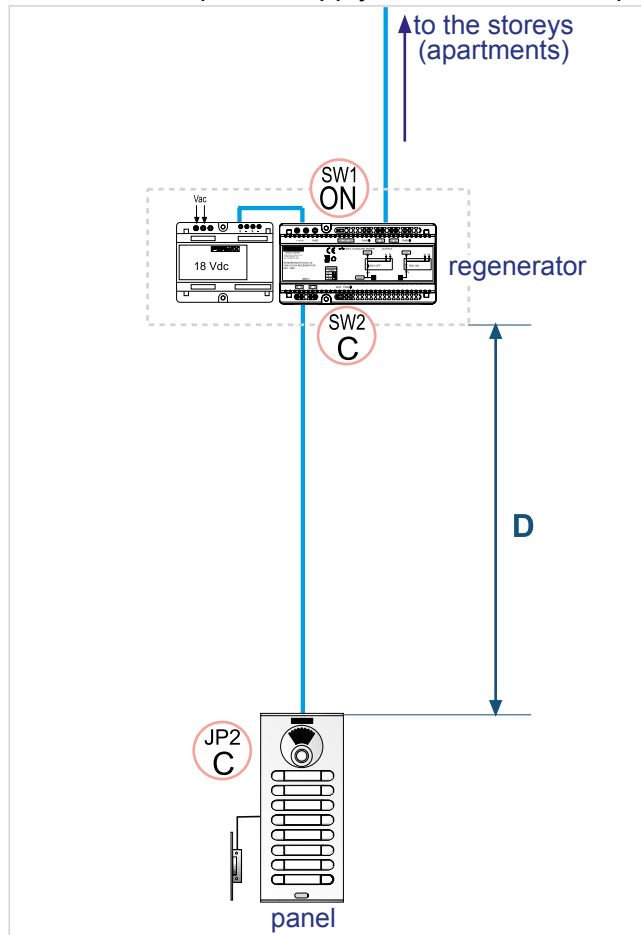

Example 2: Regenerator **WITH** a power supply set in the outdoor panel

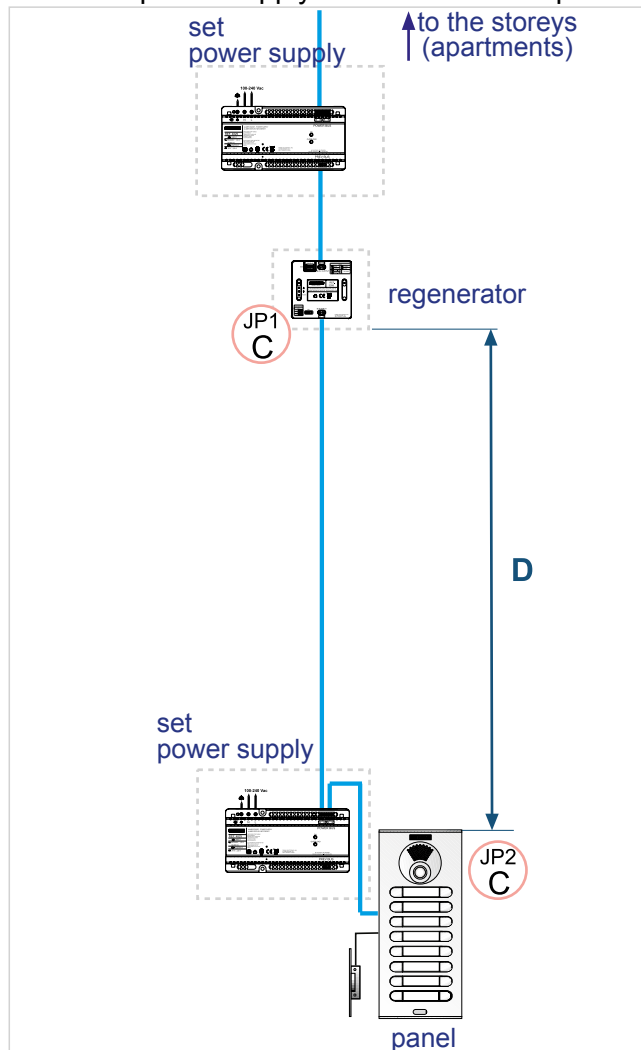

- Dividing an extended installation into several basic installations.

See Example.

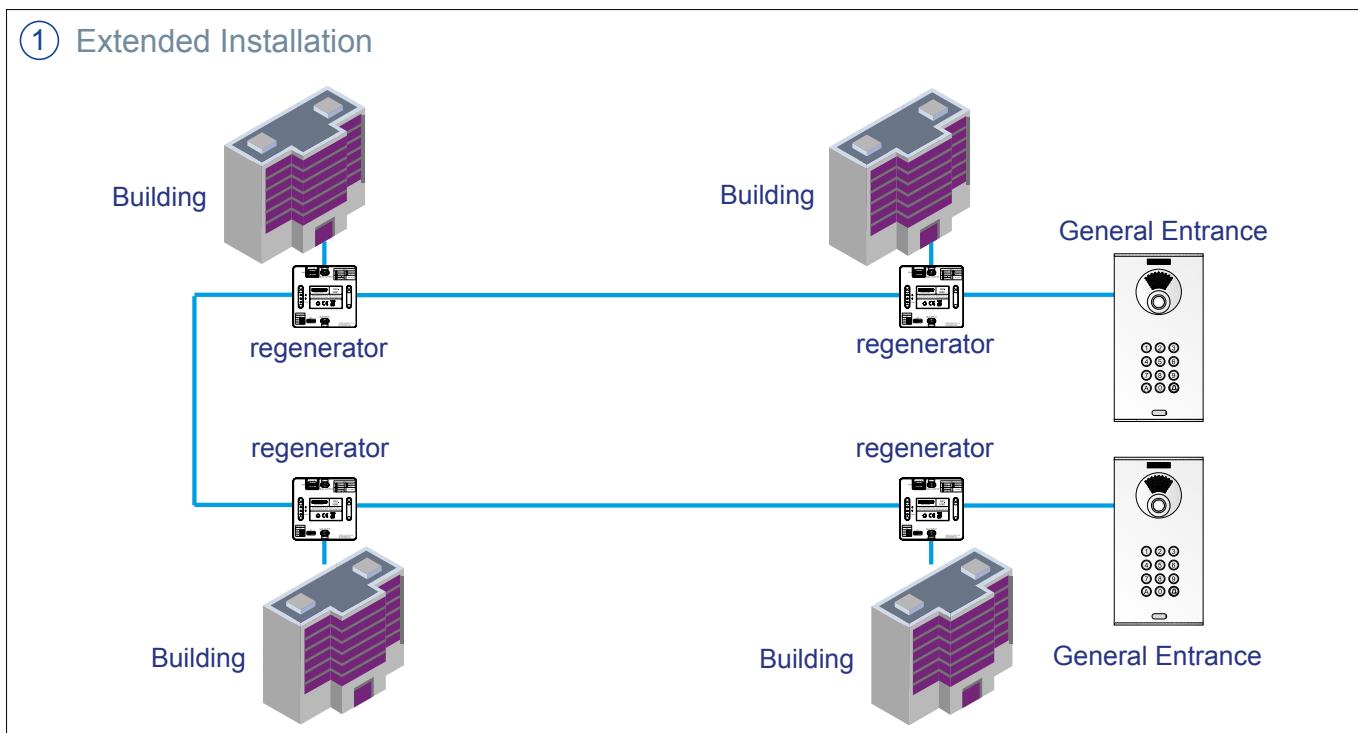

Extended Installation = 4 x Building Installation + Regenerator bus and General Entrances.

①

②

③

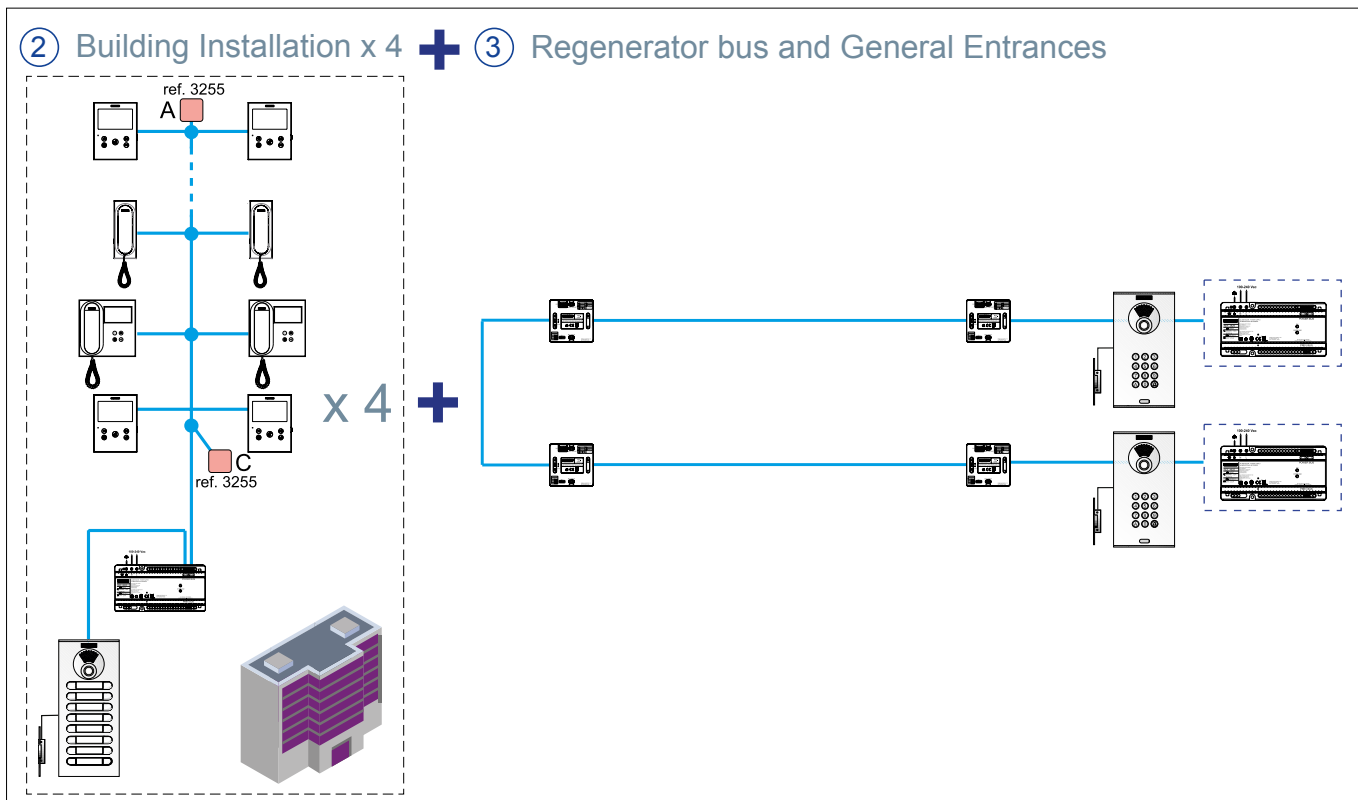

FERMAX

Avd. Tres Cruces, 133
46017 Valencia
Spain