

ALES

WS

INFRARED BARRIER

BATTERY POWERED

DOUBLE BEAMS



Index

1	MAIN COMPONENT LIST	Pag. 3
2	INSTALLATION TIPS	Pag. 5
3	INSTALLATION	Pag. 5
	DEVICE MOUNTING	Pag. 5
4	CONNECTIONS AND DESCRIPTIONS	Pag. 7
5	TRANSMITTER BOARD	Pag. 7
6	RECEIVER BOARD	Pag. 8
7	FREQUENCY SELECTION	Pag. 9
8	ALIGNMENT TEST	Pag. 10
9	ALARM SENSITIVITY ADJUSTMENT	Pag. 11
10	TECHNICAL FEATURES	Pag. 11
11	F.A.Q.	Pag. 12

Installation recommendation

- *Verify that the beam tower is fully watertight once the cover and end caps have been correctly filled at the end of the installation.*
- *The missed used of proper accessories decrease the IP grade protection of the product.*
- *Avoid any type of obstruction between the transmitter and receiver.*
- *Avoid installation of receivers beams in a position where are exposed to direct sunlight (with same angle), especially at sunset and sunrise.*
- *Do not install multiple beams where the transmitter beam can interfere with other receiver beams. It is always better place either transmitter or receivers back to back.*

1. MAIN COMPONENT LIST

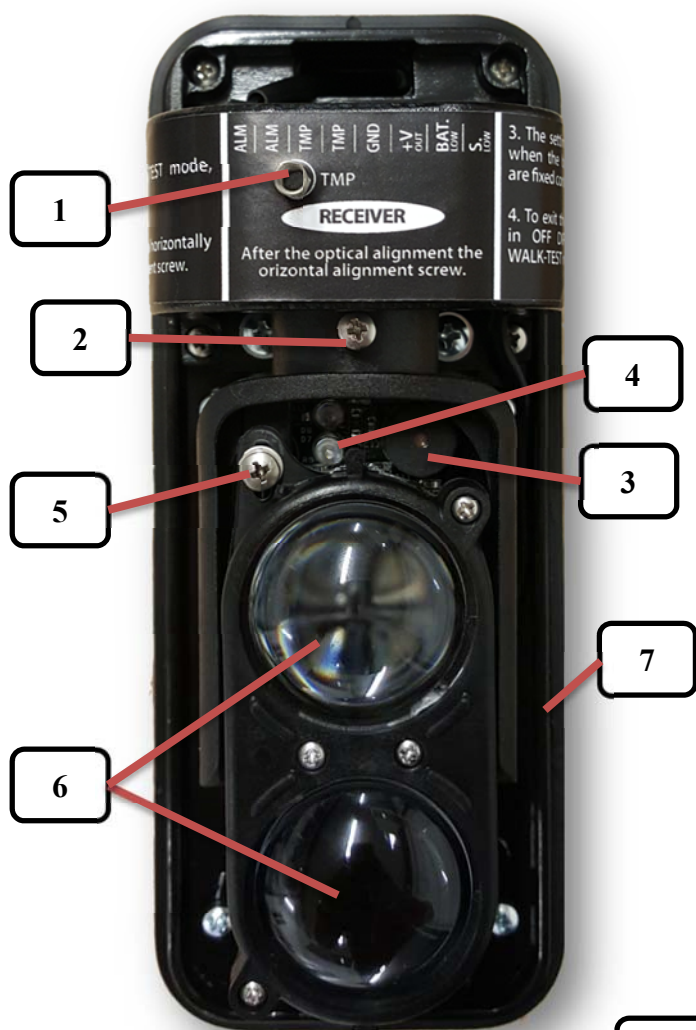

- 1 Tamper switch
- 2 Horizontal adjustment screw
- 3 Adjustment buzzer (RX)
- 4 Adjustment high frequency led (RX)
- 5 Vertical adjustment screw
- 6 Lens
- 7 Unit base
- 8 Battery case
- 9 Battery 3.6 V 19 Ah
- 10 Battery clip lock
- 11 Gasket
- 12 compartment for radio transmitter
- 13 Mounting plate
- 14 IR cover

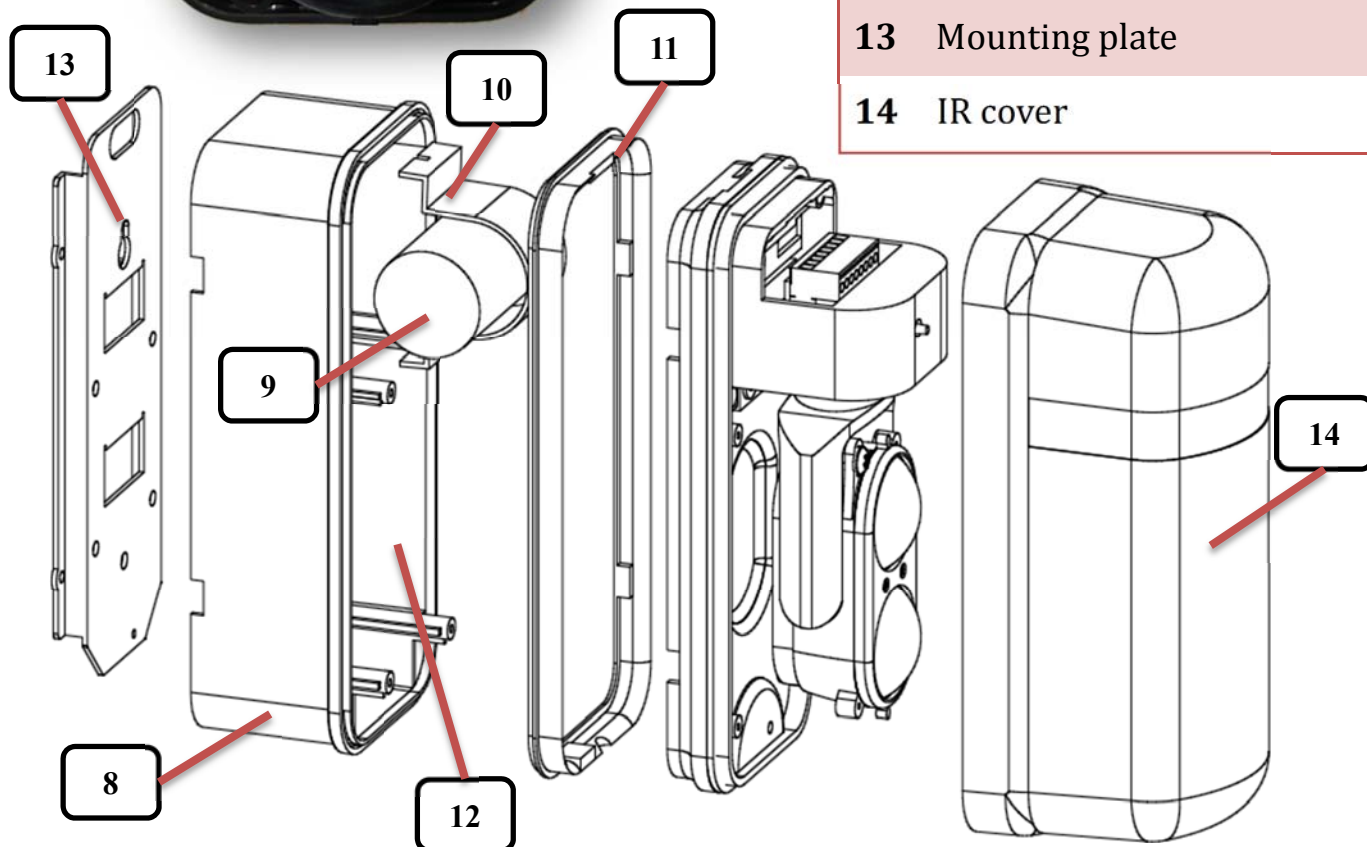



**IR
COVER**



**MOUNTING
PLATE**



**“U” BRACKET
FOR POLE
MOUNTING**



**VELCRO TAPE FOR
RADIO TRANSMITTER**

2. INSTALLATION TIPS

For proper installation of the product is necessary to remove all possible obstacles between the transmitter and receiver (trees, grass, etc..), use for the installation immovable poles or walls firmly anchored to the ground.

You should also always use cables with screen for alarm connections, proper sizing by taking more precautions due to electronic devices.

To avoid interfering with the performance and the degree of protection (IP) of the barrier is necessary to take the necessary precaution, taking care not to alter seals, plastic and mechanical parts of the product, using original accessories.

In case of repairs covered by warranty (2 years) but with obvious signs of improper installation, the Politec s.r.l. reserves the right to decide on any repair costs.

► *Avoid installation of receivers beams in a position where are exposed to direct sunlight (with same angle), especially at sunset and sunrise.*

3. INSTALLATION

The barrier ALES can be installed to the wall using the mounting plate and the pole using the mounting plate and the "U" bracket (Pole \varnothing 48-50).

DEVICE MOUNTING

► **While opening, pay attention to do not remove completely the screws at optic side, to avoid the O-ring falling.**

1. Fix the mounting plate to the wall (or to pole using the provided "U" bracket);

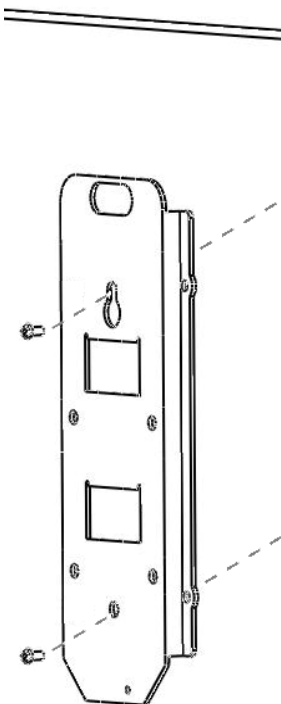

2. Insert the insulating gasket on the battery case and fix it all to the mounting plate,

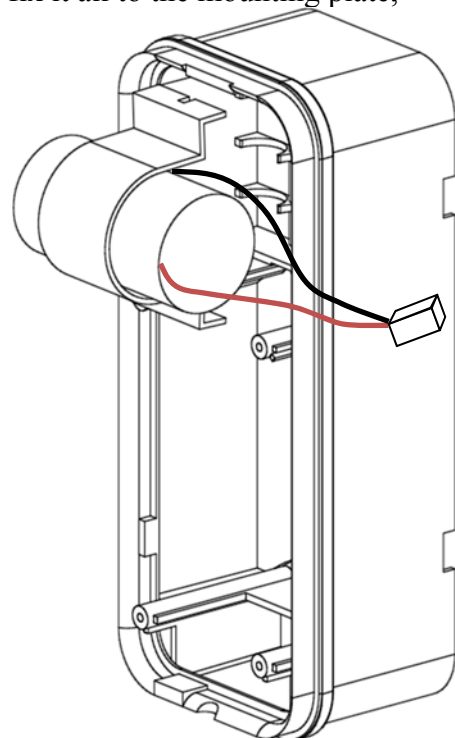

3. Stick Velcro tape on the radio transmitter and fix it on the back of the sensor;
4. Connect with proper screened cable the radio transmitter to the termina block RX (pages 7-8);

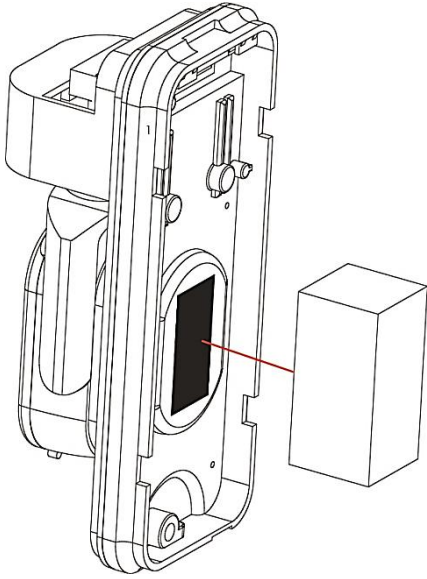

5. Insert the power cord into the unit base, through the hole,
6. Fix unit base on the battery case by tightening the 4 screws;

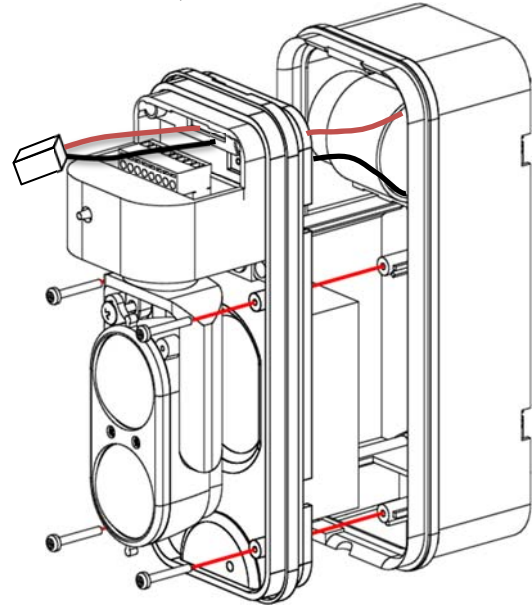

7. Connect the power cord into the main board, paying attention to polarity (**BLACK WIRE TO EXTERNAL SIDE**),

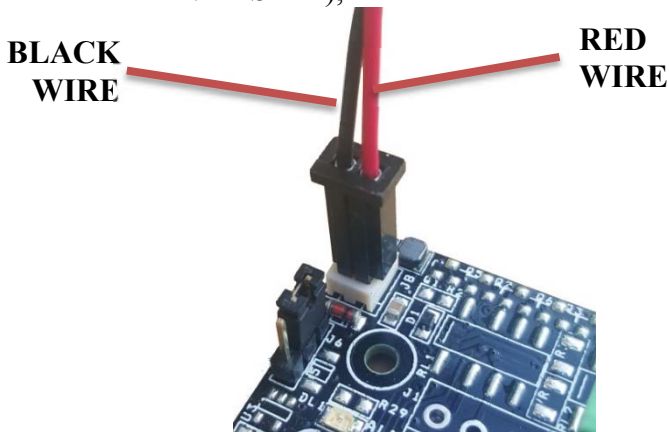

8. Hang barrier onto fixed bracket;

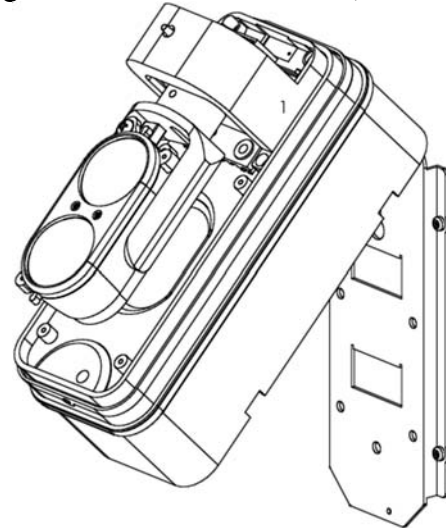

9. Fix barrier to bracket tightening screw through hole under optical and proceed with alignment of barrier;

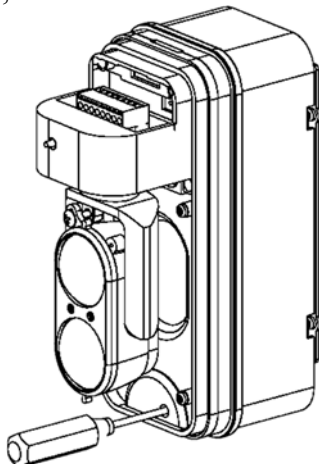

10. After alignment procedure and function test (pages 10-11), replace IR cover and tighten the under placed screw.

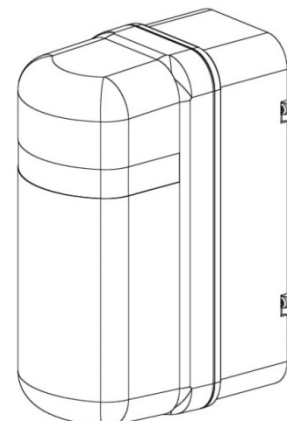

4. CONNECTIONS AND DESCRIPTIONS

To connect radio transmitter to ALES WS main board use a screened cable, connecting also the cable screen to the GND on terminal board.

- ▶ *in case of missed connection of cable screen into GND, some disturbs could be injected into the system causing a bad operability of the product.*



5. TRANSMITTER BOARD

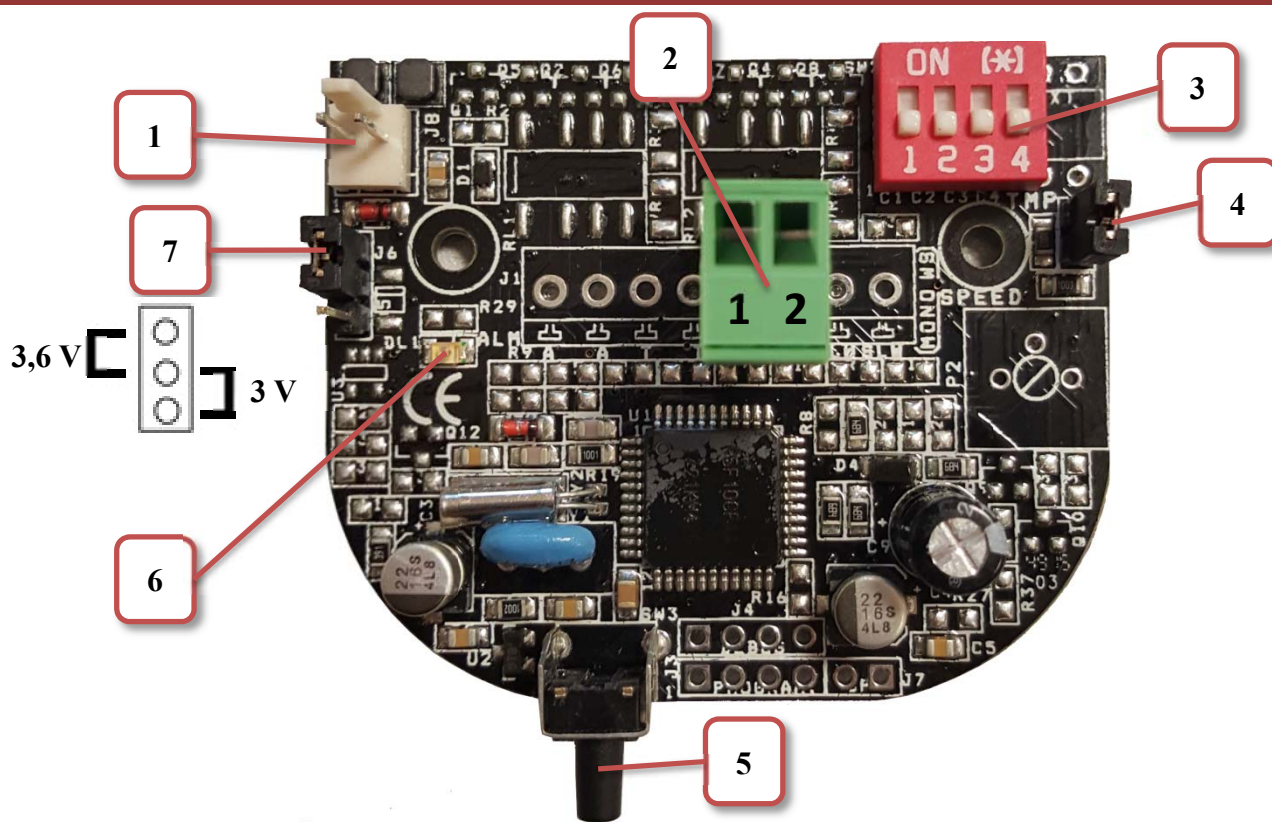

1	POWER CONNECTOR	Connection for power cord (batteries 3,6 V – 10,8 Ah)
2	TERMINAL BLOCK	1 GND 2 V+=3.6
3	CHANNELS SELECTOR DIPSWITCH	1 Activate a channel (1 of 4) positioning one dipswitch per time to ON. ▶ <i>make sure that the same channel is selected on TX and RX.</i> 3 Positioning all dipswitch of transmitter in OFF, the column transmission is disabled. 4
4	TMP1 ADDITIONAL TAMPER INPUT	Additional tamper input, in case of absence, MUST remain closed by jumper.
5	TMP	Anti-removal cover tamper.
6	SIGNAL LED	It blinks just at power connection.
7	VOLTAGE CONFIGURATION	

6. RECEIVER BOARD

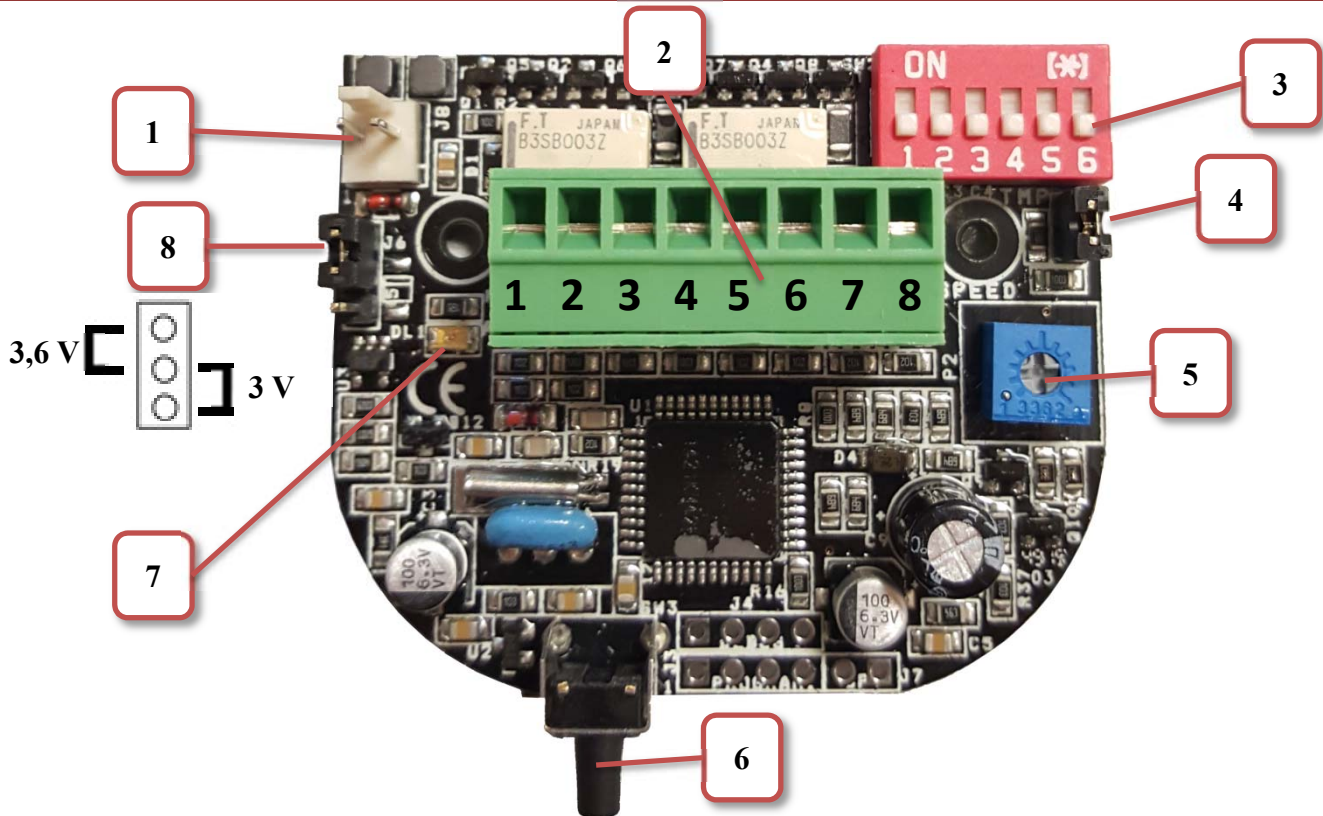

1	BATTERY INPUT	Connection for power cord (batteries 3,6 V – 10,8 Ah)
2	TERMINAL BLOCK	1 ALARM OUTPUT N.C.
		2 ALARM OUTPUT N.C.
		3 TAMPER OUTPUT
		4 TAMPER OUTPUT
		5 GND
		6 V+ =3,6V o 3V Output to supply radio transmitter.
		7 BATTERY LOW: In case of low battery, it gives a negative output signal by an open collector.
		8 ENVIROMENTAL DISQUALIFICATION: In case of heavy fog, it gives a negative output signal by an open collector.
3	DIPSWITCH	1
		2 Activate a channel (1 of 4) positioning one dipswitch per time to ON.
		3 ► make sure that the same channel is selected on TX and RX.
		4
		5 Select ON to deactivate environmental disqualification. ► The barrier, in case of heavy fog or strong condensation on IR cover (caused by missing of internal thermostat*), enter in disqualification mode which inhibits alarm output.
		6 TEST
4	TMP1 ADDITIONAL TAMPER INPUT	Tamper input additional, in case of absence MUST remain closed by jumper
5	ALARM SENSITIVITY ADJUSTMENT (see page 9)	
6	TMP	Anti-removal cover tamper.
7	SIGNAL LED	It blinks just at power connection.
8	VOLTAGE CONFIGURATION FOR RADIO TRANSMITTER SUPPLING OUTPUT (3V/3,6V).	

7. FREQUENCY SELECTION

To compose barriers or dams with more than one pair of Ales WS, it is necessary to avoid interference assign a different channel to each of them. To do this you must turn ON dip switches on the desired channel on the mother board.

► *The channel has to be the same from both the transmitter from the receiver*
(ex. CH_TX1/CH_RX1 – CH_TX2/CH_RX2 – CH_TX3/CH_RX3 – CH_TX4/CH_RX4).

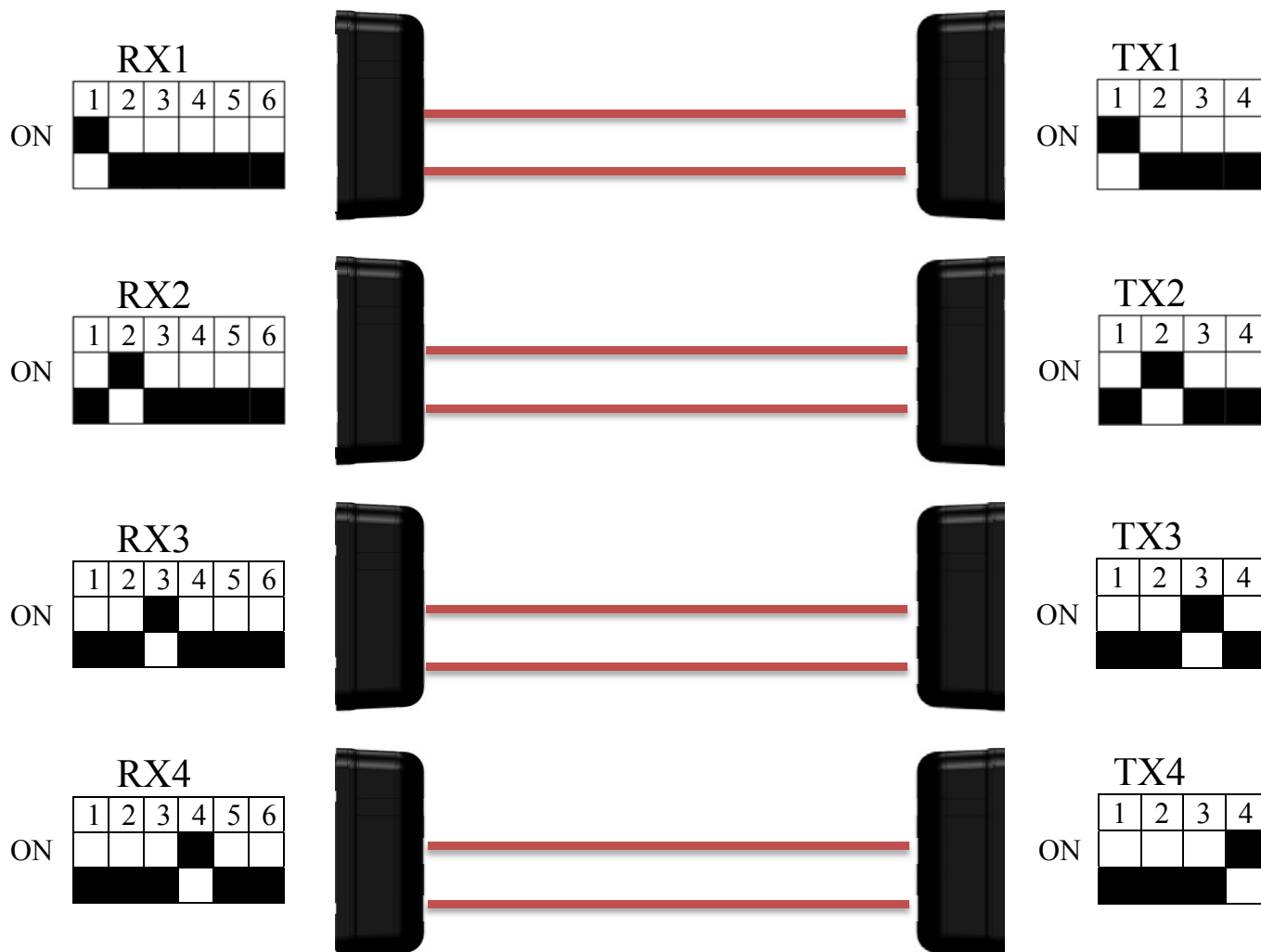

8. ALIGNMENT TEST

1. For TEST mode, Set DIP 6 to ON and DIP of desired channel on RX motherboard.

	1	2	3	4	5	6
ON		■				■
	■		■	■	■	

2. Set DIP to ON of correspondent RX channel on TX motherboard.

► *In case of damns, set OFF all other Transmitters, setting OFF channel DIP.*



3. After point 1-2, High visibility LED and buzzer (on RX optic) are turned on (if not, consult FAQ)



Align TX optic to RX, vertically and horizontally through adjustment screws to find best alignment possible. The condition of best alignment is achieved when LEDs are fixed and buzzer sounds continuously. The condition of partial or total misalignment is indicated by LEDs flashing and low frequency whistle of buzzer.

► **Buzzer sounds continuously for max 3 minutes**

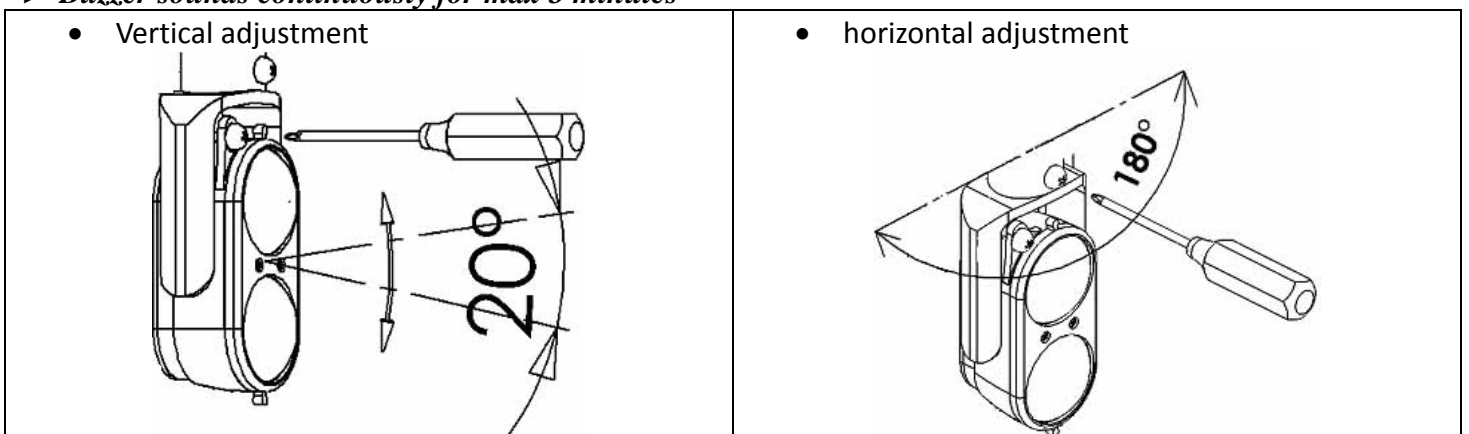

► **To get a good alignment is necessary to make a complete rotation on the optics receiver horizontal axis, thus effecting the SCANNING of the optical signal.**

- After obtained max signal, tighten horizontal adjustment screw, and exit from TEST mode setting OFF DIP 6 on RX motherboard.
- WALK-TEST: When DIP 6 is set OFF (after calibration), for 60 second every beam interruption is associate with a LED flashing and a buzzer sound.

9. ALARM SENSITIVITY ADJUSTMENT

► Making a physical test and operate with potentiometer is possible to adjust beams interruption speed to: **HIGH sensitivity for fast crossing (running); LOW sensitivity for slow crossing (walking).**

Adjust potentiometer counterclockwise to increase the alarm delay up to 500ms. In this condition ensures the alarm of a person walking through the barrier, with the advantage of excluding the possibility of any false alarms such as animals.

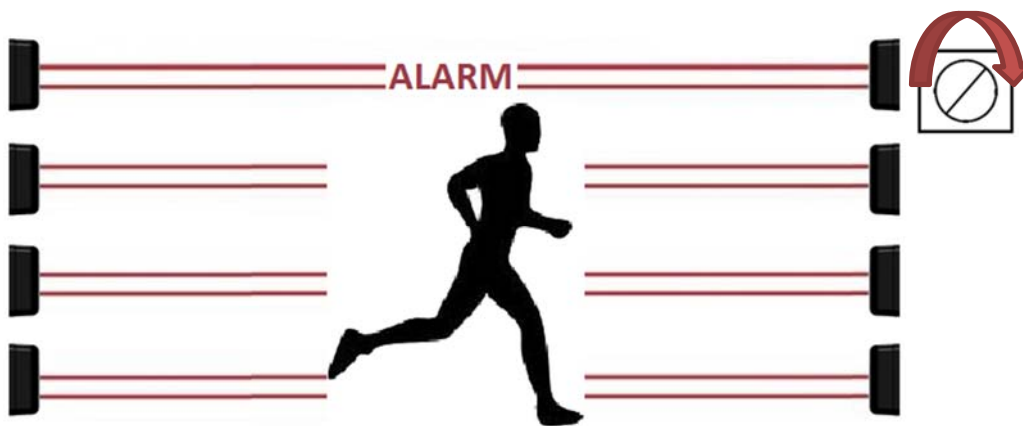
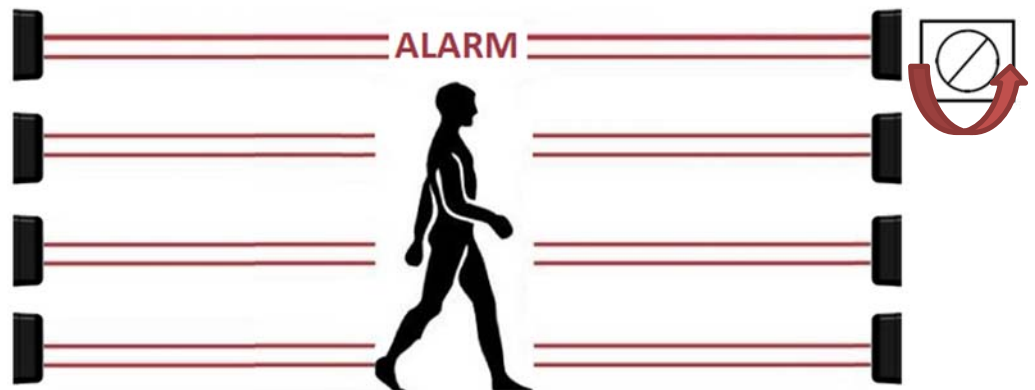

Adjusting the potentiometer clockwise to decrease the alarm delay up to 50ms. In this condition ensures the alarm of a person crossing the barrier running at maximum speed.

10. TECHNICAL FEATURES

ALES WS	
Max range indoors	150m
Max range outdoors	50 m
Synchronization	4 optical channels
Environmental disqualification	Yes, by open collector output
Setting intervention time	50 ms - 500 ms
Power source	8X Battery 3,6 V – 19 Ah
Battery life	6 years
Heaters consumption (couple)	Optional (thermostat) 10-30V: 10/15V = 6W, 0.4 A cad. 20/30V = 6W, 0.2 A cad.
Current draw	TX: 300µA RX: 350µA
Tamper output	N.C. Relay output (on RX).
Operating temperature	-25° (with heaters) +65°
IP protection	IP65.
Mounting	Indoor/outdoor. Wall/pole/tower. brackets included for wall/pole
TOTAL WARRANTY 2 YEARS	

11. F.A.Q.

• I can't find alignment

- Check no obstacles are placed between TX and RX and site conformation not gives itself an obstacle to installation;
- Check that barriers are supplied and batteries charged;
- Make sure that no other external lights are interesting RX side, during function TEST (gate photocell, any other barrier, infrared lights, exc...).

• After best signal achieved (LEDs are fixed and buzzer sounds continuously) barrier stays in alarm

- Make sure RX and TX have same channel;
- Make sure that no other external lights are interesting RX side, during function TEST (gate photocell, any other barrier, infrared lights, exc...);
- Make sure while Alignment TEST other TX (in case of dams) are OFF.

• System in alarm with fog or rain

- Make sure environmental disqualification is activated;
- Make sure columns are well closed and check inside there are no presence of water or insects;
- Check the precision of alignment and in case remake alignment TEST, making sure that no other external lights are interesting RX side (gate photocell, any other barrier, infrared lights, exc...);

• Repeated false alarms

- If possible, increase the alarm delay up;
- Make sure to have used a correct screened cable and linked screen to GND of ALES WS motherboard.