



SMILE 19 - SMILE 19/P SENSOR PIR INMUNE A MASCOTAS



1. INTRODUCTION

SMILE 19 is a Digital PIR sensor, with an analysis system that takes into account the two most important changes that may occur during a movement: the speed and the intensity. With the simultaneous comparison of these two information, the sensor is able to discriminate repetitive movements from intrusion, lowering the percentage of false alarms. With high thermal variations, the totally digital temperature compensation system, guarantees a great performance. Has 51mt coverage, with angle of 90°. With the special lens is equipped of creep zone. Is available also in pet immune up to 15 kg version (Smile 19/P). To disassemble the detector just press the tooth on the bottom of the case (see figure) and pull out the PCB by pushing the clip and by levering on the ABS supports (see figure). In this way it will be possible to freely work on the PCB.

2. INSTALLATION PROCEDURE

- By using a thin screwdriver, push the round tooth on the bottom and open the housing (see figure 1)
- Remove the PCB from the base by levering on the ABS supports (see figure 2)
- Pierce the knock on the base of cover on the desired point for fixing, or use the optional swivel bracket.
- recommended height 2mt
- slide the cable into the back seat, and out of the top hole
- Wire up the terminals following the connections shown in figure.

3. ADJUSTMENTS AND CONNECTION

To disable the walk test LED open the JP2 LED

To enable double pulse close the JP1

AP: Tamper terminal

ALARM Alarm terminal

SUPPLY: power supply 13.8Vcc

1. INTRODUCCIÓN

SMILE 19 es un sensor infrarrojos digital, con un sistema de análisis que tiene en cuenta las dos variaciones más importantes que pueden ocasionarse durante un movimiento: la velocidad y la intensidad.

Con la comparación simultánea de estas 2 informaciones, el sensor es capaz de distinguir entre movimientos repetitivos y las intrusiones efectivas, reduciendo considerablemente el porcentaje de falsas alarmas. El sistema de compensación térmica completamente digital garantiza siempre la máxima eficacia incluso en presencia de considerables variaciones térmicas. Tiene un alcance de unos 15 m con ángulo de apertura de 90° y la lente especial nido de abeja permite también el control antiarrastré. También está disponible en la configuración inmune a las mascotas de hasta 15 kg (smile19). Para acceder a la tarjeta electrónica, sólo hay que pulsar la tecla en el fondo de la cubierta (vea la imagen) y, haciendo palanca sobre los bloques en ABS, será posible extraer la tarjeta electrónica y trabajar con total libertad.

2. INSTALACIÓN

Utilice un pequeño destornillador, empuje el botón redondo que se encuentra en la parte delantera del sensor y abra la cubierta.

- retire la tarjeta electrónica del fondo de la cubierta haciendo palanca sobre el enganche del lado de los bornes.
- perforé los agujeros ciegos de montaje que se van a utilizar para la fijación, o bien utilice la articulación correspondiente (opcional). - La altura recomendada para la fijación es 2 m.
- haga deslizar el cable por la guía correspondiente que se encuentra en la parte trasera de la cubierta, haciendo que salga por el agujero que está en la parte superior.
- efectúe el cableado del circuito siguiendo la guía para las conexiones (figura 3).

3. AJUSTES Y CONEXIONES

Para desactivar totalmente el led prueba de movimiento se puede abrir el JP2 LED

Para habilitar el doble impulso, JP1 cerrado.

AP: terminal tamper

ALARM: terminal alarma

SUPPLY: alimentación 13.8Vcc

GENERAL VIEW / VISTA GENERAL

INSIDE VIEW / VISTA INTERNA

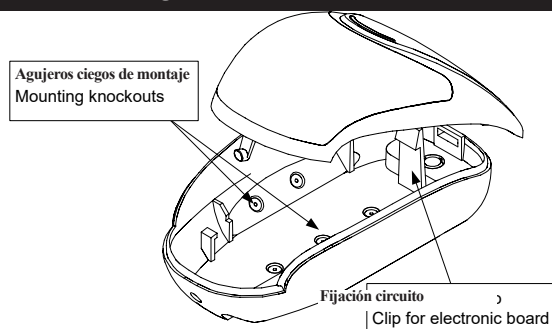
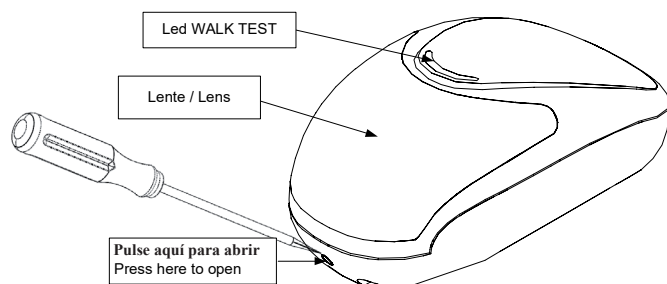

LENS / LENTES

PET IMMUNE

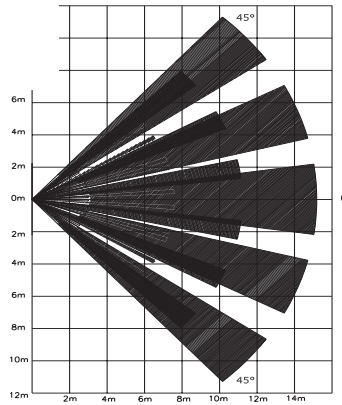
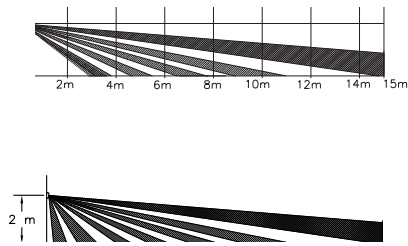

SMILE 19 posibilita una cobertura de 15 m, la conformación especial de la lente posibilita una apertura horizontal de más de 90° con 29 haces en 5 niveles

SMILE 19 allows a range of 15 m, the special lens shape provides a horizontal coverage of more than 90° with 29 patterns on 5 levels.

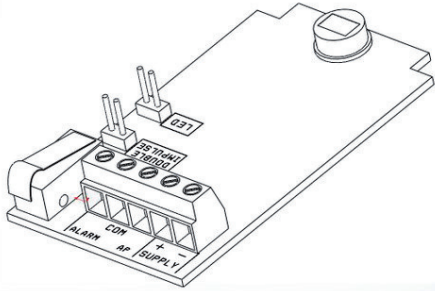

JP1 = double pulse
JP2 = Walk test led
ALARM = alarm contact
AP = tamper contact
SUPPLY = power supply 13.8Vcc

JP1 = doble impulso
JP2 = led de prueba de movimiento
ALARM = contacto alarma
AP = contacto tamper
SUPPLY = alimentación 13.8Vcc

Doble equilibrio - 1 o 2 sensores

Double balance - 1 or 2 sensors

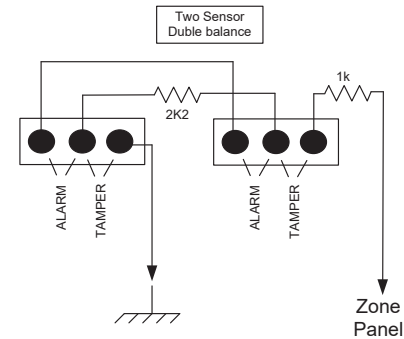
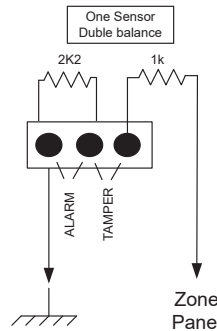

SPECIFICATIONS / CARACTERÍSTICAS

SMILE 19	
Input Voltage / Alimentación	9 to 15 Vcc
Current Drain / Consumo	(18 mA/9.5mA) @ 13.8 Vcc
Coverage / Alcance en longitud	15 mt
Angle / Alcance en ancho	90°
Piroeléctrico / PIR	2 elements/ 2 elements
Lens / Lente	29 haces en/patterns on 5 levels/niveles
Anti-opening / Autoprotection	✓
Creep zone / Antiarrastre	✓
Alarm contact / Contacto de alarma	0.2 A - 24 Vcc
Tamper switch / Contacto de tamper	Max/ Máx 40 mA - 30 Vcc
Operating temperature / Temperatura de ejercicio	From/Desde -10 °C to/hasta +55 °C
Protection / RFI Protección	30 V / m (20 MHz - 2000 MHz)
Led WALK TEST / Led PRUEBA DE MOVIMIENTO	✓
WALK TEST IN / PRUEBA DE MOVIMIENTO IN	✓
Housing / Cubierta	ABS
Dimensions / Dimensiones	110 x 60 x 46 mm

Meets the requirements: EN 50131-2-2 Grade 2 EN 50131-2-2 Class 2

Cumple los requisitos: EN 50131-2-2 Grado 2 EN 50131-2-2 Clase 2

Installation must be carried out following the local installation norms by qualified personnel.

The manufacturer refuses any responsibility when changes or unauthorized repairs are made to the product/system.

It is recommended to test the operation of the alarm product/system at least once a month. Despite frequent testing and due to, but not limited to, any or all of the following: tampering, electrical or communication disruption or improper use, it is possible for the product/system to fail to prevent burglary, robbery, fire or otherwise. A properly installed and maintained alarm system can only reduce the risk that this happens.

La instalación debe ser realizada correctamente por personal especializado.

El fabricante declina cualquier responsabilidad en caso de que el producto sea manipulado por personas no autorizadas.

Se recomienda verificar el correcto funcionamiento del sistema de alarmas al menos una vez al mes, a pesar de ello, tenga en cuenta que un sistema de alarmas electrónico fiable no evita las intrusiones, atracos, incendios y demás, sino que se limita a disminuir el riesgo de que dichas situaciones se ocasionen.

1. INTRODUCTION

SMILE 19 is a Digital PIR sensor, with an analysis system that takes into account the two most important changes that may occur during a movement: the speed and the intensity. With the simultaneous comparison of these two information, the sensor is able to discriminate repetitive movements from intrusion, lowering the percentage of false alarms. With high thermal variations, the totally digital temperature compensation system, guarantees a great performance. Has 15mt coverage, with angle of 90°. With the special lens is equipped of creep zone. Is available also in pet immune up to 15 kg version (Smile19/P). To disassemble the detector just press the tooth on the bottom of the case (see figure) and pull out the PCB by pushing the clip and by levering on the ABS supports (see figure). In this way it will be possible to freely work on the PCB.

2. INSTALLATION PROCEDURE

- By using a thin screwdriver, push the round tooth on the bottom and open the housing (see figure 1)
- Remove the PCB from the base by levering on the ABS supports (see figure 2)
- Pierce the knock on the base of cover on the desired point for fixing, or use the optional swivel bracket.
- recommended height 2mt
- slide the cable into the back seat, and out of the top hole
- Wire up the terminals following the connections shown in figure.

3. ADJUSTMENTS AND CONNECTION

To disable the walk test LED open the JP2 LED

To enable double pulse close the JP1

AP: Tamper terminal

ALARM Alarm terminal

SUPPLY: power supply 13.8Vcc

1. INTRODUZIONE

SMILE 19 è un sensore infrarosso digitale, con un sistema di analisi che tiene in considerazione le 2 più importanti variazioni che possono avvenire durante un movimento: la velocità e la l'intensità.

Con la comparazione simultanea di queste 2 informazioni il sensore è in grado di discriminare movimenti ripetitivi da intrusioni vere e proprie, abbassando la percentuale di falsi allarmi in modo considerevole. Anche in presenza di variazioni termiche notevoli il sistema di compensazione termica totalmente digitale garantisce sempre un ottima efficacia. Ha una portata di circa 15mt, con un angolo di apertura di 90° e la speciale lente a nido d'ape permette anche il controllo antistrisciamento. E' diponibile anche nella versione pet immune fino a 15kg (smile19/P). Per accedere alla scheda elettronica sarà sufficiente fare pressione su un tasto sul fondo della cover (vedi figura) e, facendo leva sui blocchetti in ABS, si potrà estrarre la scheda elettronica e lavorare in piena libertà.

2. INSTALLAZIONE

Utilizzando un mini cacciavite, spingere il tastino tondo sul lato anteriore del sensore e aprire la cover.

- rimuovere la scheda elettronica dal fondo della cover facendo leva sulla clips lato morsetti
- forare gli sfondabili che si desidera utilizzare per il fissaggio, oppure utilizzare l'apposito snodo (opzionale).
- Altezza consigliata per il fissaggio 2m.
- fare scorrere il cavo attraverso l'apposita guida sul retro della cover facendolo uscire dal foro in alto.
- cablare il circuito seguendo la guida ai collegamenti (figura 3).

3. REGOLAZIONI E COLLEGAMENTI

Per disabilitare completamente il led walk test si può aprire il JP2 LED

Per abilitare il doppio impulso chiudere il JP1.

AP: terminale tamper

ALARM: terminale allarme

SUPPLY: alimentazione 13.8Vcc

GENERAL VIEW

INSIDE VIEW

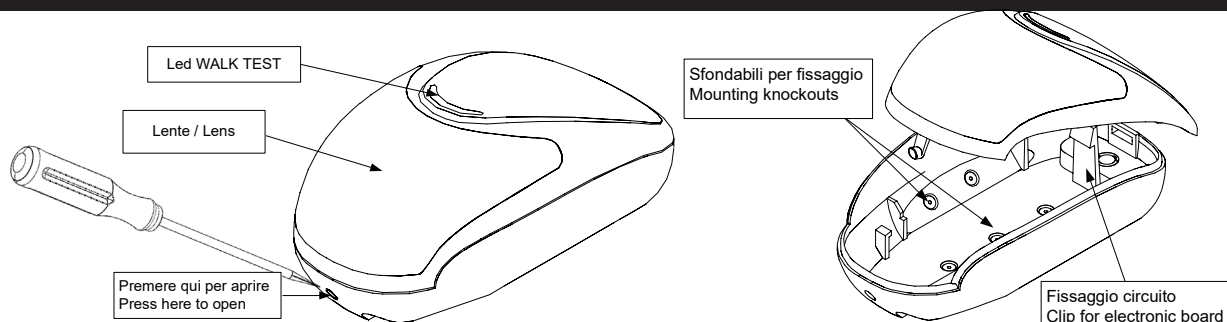

PET IMMUNE

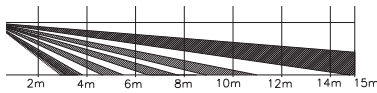

NORMAL

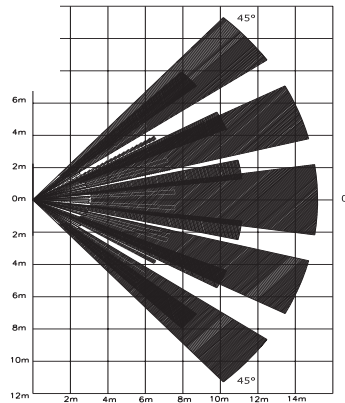

SMILE 19 permette una copertura di 15 mt, la speciale conformazione della lente permette un'apertura orizzontale di oltre 90° con 29 fasci su 5 livelli

SMILE 19 allows a range of 15 mt, the special lens shape provides a horizontal coverage of more than 90° with 29 patterns on 5 levels.

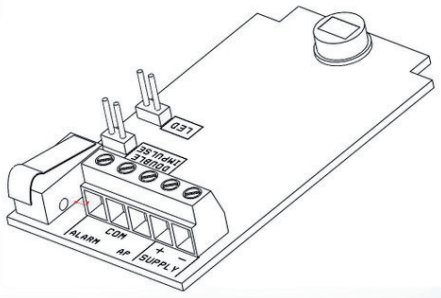

JP1 = double pulse
JP2 = Walk test led
ALARM = alarm contact
AP = tamper contact
SUPPLY = power supply 13.8Vcc

JP1 = doppio impulso
JP2 = Walk test led
ALARM = contatto allarme
AP = contatto tamper
SUPPLY = alimentazione 13.8Vcc

Doppio bilanciamento - 1 o 2 sensori

Double balance - 1 or 2 sensors

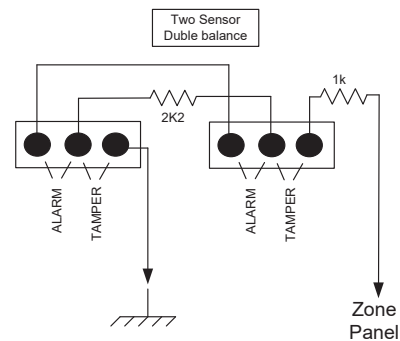
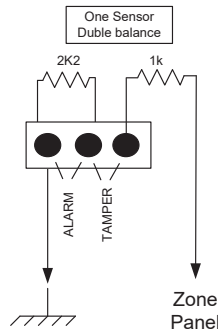

SPECIFICATIONS

SMILE 19	
Alimentazione / Input Voltage	9 to 15 Vcc
Consumo / Current Drain	(18 mA/9.5mA) @ 13.8 Vcc
Portata in lunghezza / Coverage	15 mt
Portata in larghezza / Angle	90°
Piroelettrico / PIR	2 elementi / 2 elements
Lente / Lens	29 patterns on 3/5 levels
Antiapertura / Anti-opening	✓
Antistrisciamento / Creep zone /	✓
Contatto di allarme / Alarm contact	0.2 A - 24 Vcc
Contatto di tamper / Tamper switch	Max 40 mA - 30 Vcc
Temperatura di esercizio / Operating temperature	From -20 °C to +55 °C
RFI Protezione / Protection	30 V / m (20 MHz - 2000 MHz)
Led WALK TEST	✓
WALK TEST IN	✓
Cover / Housing / Boiter	ABS
Dimensioni / Dimensions	110 x 60 x 46 mm

Meets the requirements: EN 50131-2-2 Grade 2 EN 50131-2-2 Class 2

L'installazione deve essere eseguita a regola d'arte da personale specializzato.

Il produttore declina ogni responsabilità nel caso in cui il prodotto venga manomesso da persone non autorizzate.

Si raccomanda di verificare il corretto funzionamento del sistema d'allarme almeno una volta al mese, tuttavia un sistema di allarme elettronico affidabile non evita intrusioni, rapine, incendi o altro, ma si limita a diminuire il rischio che tali situazioni si verifichino.

Installation must be carried out following the local installation norms by qualified personnel.

The manufacturer refuses any responsibility when changes or unauthorized repairs are made to the product/system.

It is recommended to test the operation of the alarm product/system at least once a month. Despite frequent testing and due to, but not limited to, any or all of the following: tampering, electrical or communication disruption or improper use, it is possible for the product/system to fail to prevent burglary, robbery, fire or otherwise. A properly installed and maintained alarm system can only reduce the risk that this happens.