



Declaration of Conformity



Type of equipment: ANALOG CAMERA
Brand Name /Trade Mark: HANWHA
Type designation /model: SCO-6083RP
Applicant: Hanwha Techwin Company Limited

In accordance with the following Directives:

2004/108/EC The Electromagnetic Compatibility Directive
Including amendments by the CE Marking Directive 93/68/EEC

2011/65/EU Restriction of the use of certain hazardous substances in electrical and electronic equipment (recast)

The following harmonized European standards or technical specifications have been applied:

EN 55022:2010	Limits and methods of measurement of radio disturbance characteristics of information technology equipment
EN 50581:2012	Technical documentation for the assessment of electrical and electronic products with respect to the restriction of hazardous substances
EN 50130-4:2011+A1:2014	Product family standard: Immunity requirements for components of fire, intruder and social alarm systems
EN 61000-3-3:2013	Limitation of voltage changes, voltage fluctuations and flicker in public low-voltage supply systems, for equipment with rated current ≤ 16 A per phase and not subject to conditional connection
EN 61000-4-2:2009	Electrostatic discharge immunity test
EN 61000-4-3:2006+A2:2010	Radiated, radio-frequency, electromagnetic field immunity test
EN 61000-4-4:2012	Electrical fast transient/burst immunity test
EN 61000-4-5:2014	Surge immunity test
EN 61000-4-6:2009	Immunity to conducted disturbances, induced by radio-frequency fields
EN 61000-4-11:2004	Voltage Dips and Voltage Interruptions Immunity test

The CE Marking on the products and/or their packaging signifies that Hanwha Techwin Company Limited holds the reference technical file available to the European Union authorities.

Place and date of issue: 1204, Changwon-daero, Seongsan-gu, Changwon-si, Gyeongsangnam-do, Korea / Dec 17, 2015

Authorized Signatory: Name : Jei Soon, Kang
Title : Principal Research Engineer

Signatur :

CE Conformance EMC Test Report

Test Report No. : KES-E1-15T0342
Date of Issue : 12. 17. 2015
Description of Product : ANALOG CAMERA
Model No. : SCO-6083RP
Variant Model : -
Applicant : Hanwha Techwin Company Limited
Address : 1204, Changwon-daero, Seongsan-gu, Changwon-si, Gyeongsangnam-do, korea
Manufacturer : Tianjin Samsung Electronics Co.,Ltd.
Address : No.11 Weiliu Rd, Micro-Electronic Industrial Park, TEDA, Tianjin, 300385, People's Republic of China
Applicable Regulation : **EMC Directive 2004/108/EC**
EN 55022:2010
EN 50130-4:2011+A1:2014
EN 61000-3-3:2013

Date of Receipt : 12. 03. 2015
Test Date : 12. 09. 2015 ~ 12. 11. 2015

Tested by:

Hyo Jin, Kim
Test Engineer

Reviewed by:

Dong Hun, Jang
Technical Manager



Testing Laboratories for Safety and RF Compliance
C-3701 40, Simin-daero 365beon-gil, Dongan-gu, Anyang-si, Gyeonggi-do, 14057, Korea
Tel: +82-31-425-6200 / Fax: +82-31-424-0450

Testing Laboratories for EMC Compliance
473-29, Gayeoro, Yeosu-si, Gyeonggi-do, 12658, Korea
Tel : +82-31-883-5092 / Fax: +82-31-883-5169

This report shall not be reproduced except in full, without the written approval of KES Co., Ltd.

The results shown in this test report refer only to the sample(s) tested unless otherwise stated.



KES Co., Ltd.

C-3701, 40, Simin-daero 365beon-gil,
Dongan-gu, Anyang-si, Gyeonggi-do, 14057, Korea
Tel: +82-31-425-6200 / Fax: +82-31-424-0450
www.kes.co.kr

Test report No.:
KES-E1-15T0342
Page (2) of (74)

Revision history

Revision	Date of issue	Test report No.	Description
-	12. 17. 2015	KES-E1-15T0342	Initial

This report shall not be reproduced except in full, without the written approval of KES Co., Ltd.

The results shown in this test report refer only to the sample(s) tested unless otherwise stated.



TABLE OF CONTENTS

1	General Information	4
2	Product Labelling Requirements	9
3	Applicable Regulations	10
4	Test standards and results	13
5	Test Performed	14
5.1	Conducted Emission Measurements	14
5.2	Radiated Emission Measurements	20
5.3	Harmonics / Voltage Fluctuations Measurements	32
5.4	Electrostatic Discharge Immunity	36
5.5	Radio-frequency electromagnetic field Amplitude modulated Immunity	39
5.6	Fast Transients Immunity	42
5.7	Surge Immunity	46
5.8	Radio-frequency continuous conducted Immunity	48
5.9	Voltage Dips and Interruptions Immunity	51
6	Test Setup Photographs	53
6.1	Conducted Emission	53
6.2	Radiated Emission	55
6.3	Harmonics / Voltage Fluctuations Measurements	57
6.4	Electrostatic Discharge Immunity	57
6.5	Radio frequency electromagnetic field immunity	60
6.6	Fast Transients Immunity	61
6.7	Surge Immunity	62
6.8	Radio-frequency continuous conducted Immunity	63
6.9	Voltage Dips and Interruptions Immunity	64
7	External Photographs	65
8	Internal Photographs	67
	Appendix A	73
	Appendix B	74

This report shall not be reproduced except in full, without the written approval of KES Co., Ltd.

The results shown in this test report refer only to the sample(s) tested unless otherwise stated.

1. General Information

1.1 Introduction

The EMC Test Report for CE Declaration of Conformity is prepared on behalf of named applicant in accordance with the EMC Directive(2004/108/EC) of the European Economic Community. The test results reported in this document relate only to the item that was tested.

All radiated emission, conducted emission measurements required by the EMC Directive were performed manually at KES Co., Ltd. (here in after called KES), 473-29, Gayeo-ro, Yeosu-si, Gyeonggi-do, 12658 KOREA.

The radiated emission measurements performed on 10 meter, Open Area Test Site, test range maintained by KES. Complete ANSI63.4;2009 description and site attenuation measurement data records are maintained at the test facility and have been placed on file with the Federal Communications Commission.

All immunity measurements required by the EMC Directive were performed manually at KES Co., Ltd. (here in after called KES), 473-29, Gayeo-ro, Yeosu-si, Gyeonggi-do, 12658 KOREA.

The immunity measurements were performed in a shielded enclosure and/or anechoic chamber also located at the same facility.

The KES EMC test facilities in Yeosu-si are designated testing laboratory according to ISO/IEC 17025 by Radio Research Agency(RRA), Korea Communication Commission.

1.2 Product Description for Equipment Under Test (E.U.T)

Hanwha Techwin Company Limited, ANALOG CAMERA, Model No: SCO-6083RP or the "E.U.T" as referred to in this report is base model.

Main Specifications of EUT are:

SCO-6083R	
Video	
Imaging Device	1/2.9" 2M CMOS
Total Pixels	2,000(H) x 1,121(V) 2.24M pixels
Effective Pixels	1,984(H) x 1,105(V) 2.19M pixels
Scanning System	Progressive Scan
Horizontal Resolution	900TVL
Min. Illumination	Color : 0.05Lux (F1.2, 50IRE) B/W : 0Lux(IR LED on)
S / N Ratio	52dB (AGC off, Weight on)
Video Output	BNC(AHD, CVBS Selectable)
Resolution	1920 x 1080
Max. Framerate	30fps @1080p, 30fps@ 720p
Lens Type	
Focal Length (Zoom Ratio)	2.8 ~ 12mm (4.3x) varifocal
Max. Aperture Ratio	F1.4
Angular Field of View	H : 103.8 ° (Wide) ~ 32.4 ° (Tele) / V : 53.7 ° (Wide) ~ 18.4 ° (Tele) D : 121.9 ° (Wide) ~ 37.1 ° (Tele)
Min. Object Distance	0.5m (1.64ft)
Focus Control	Manual
Lens Type	DC Auto Iris
Mount Type	Board-in type
Operational	
IR LED	
Viewable length	30m (98.43ft)
Camera Title	Off / On (Displayed 15 characters)
Day & Night	Auto (ICR) / Color / B/W
Backlight Compensation	Off / User BLC / HLC
Wide Dynamic Range	D-WDR
Digital Noise Reduction	SSNR4 (Off / On)
Defog	AUTO / MANUAL / OFF
Motion Detection	Off / On(4 zones)
Privacy Masking	Off / On (4zones rectangle)
Gain Control	Off / Low / Middle / High
White Balance	ATW / Outdoor / Indoor / Manual / AWC (1,800K° ~ 10,500K°)
Electronic Shutter Speed	1sec~ 1/12,000sec
Reverse	Off / H-Rev / V-Rev / HV-Rev
Profile	Basic, Day & Night, Backlight, Indoor, User
Alarm	(MD) output 1
Remote control interface	Coaxial
Protocol	Coax : Pelco-C (Coaxitron)
Video Transmission Distance	500m
Environmental	
Operating Temperature / Humidity	-30°C ~ +55°C (-22°F ~ +131°F) / Less than 90% RH * Start up should be done at above -10°C
Ingress Protection	IP66
Vandal Resistance	IK10
Electrical	
Input Voltage/Current	Dual (24VAC±10% & 12VDC±10%)
Mechanical	
Color / Material	Dark Gray / Aluminum

This report shall not be reproduced except in full, without the written approval of KES Co., Ltd.

The results shown in this test report refer only to the sample(s) tested unless otherwise stated.



1.3 Equipment Under Test

Description	Model Number	Serial Number	Manufacturer	Remarks
ANALOG CAMERA	SCO-6083RP	-	Tianjin Samsung Electronics Co.,Ltd.	EUT

1.4 Support Equipments

Description	Model Number	Serial Number	Manufacturer	Remarks
Monitor	M1950DM	206KCRN81246	LG Electronics Inc.	-
AC/DC Adapter	PA-1650-64	OE9FA612314104362	LITE-ON TECHNOLOGY CORPORATION	-
Alarm Jig	-	-	-	-

1.5 External I/O Cabling

- AC/DC POWER Mode

Start		END		Cable Spec.	
Description	I/O Port	Description	I/O Port	Length	Shield
ANALOG CAMERA (EUT)	Alarm Out	Alarm Jig	Alarm Out	3.0	Unshielded
	BNC	Monitor	BNC	3.0	shielded

This report shall not be reproduced except in full, without the written approval of KES Co., Ltd.

The results shown in this test report refer only to the sample(s) tested unless otherwise stated.

1.6 Special Accessories

As shown in section 1.8, all interface cables used for compliance testing are shielded as normally supplied or by use respective component manufacturers.

1.7 E.U.T Modifications

No modifications were made to the E.U.T in order to achieve and maintain compliance to the standards described in this report.

1.8 Configuration of Test System

- AC POWER Mode

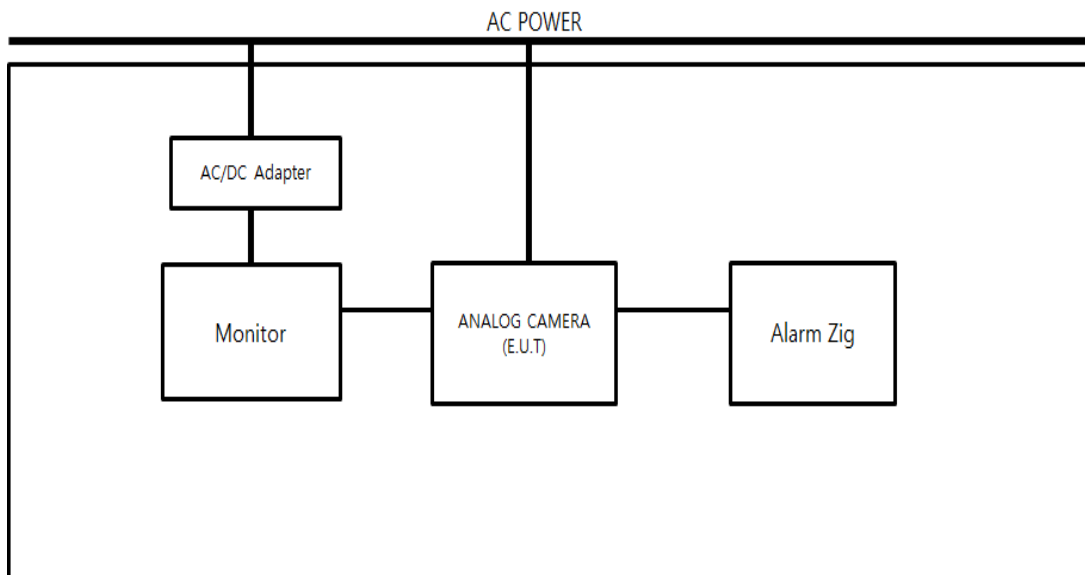

- **DC POWER Mode**

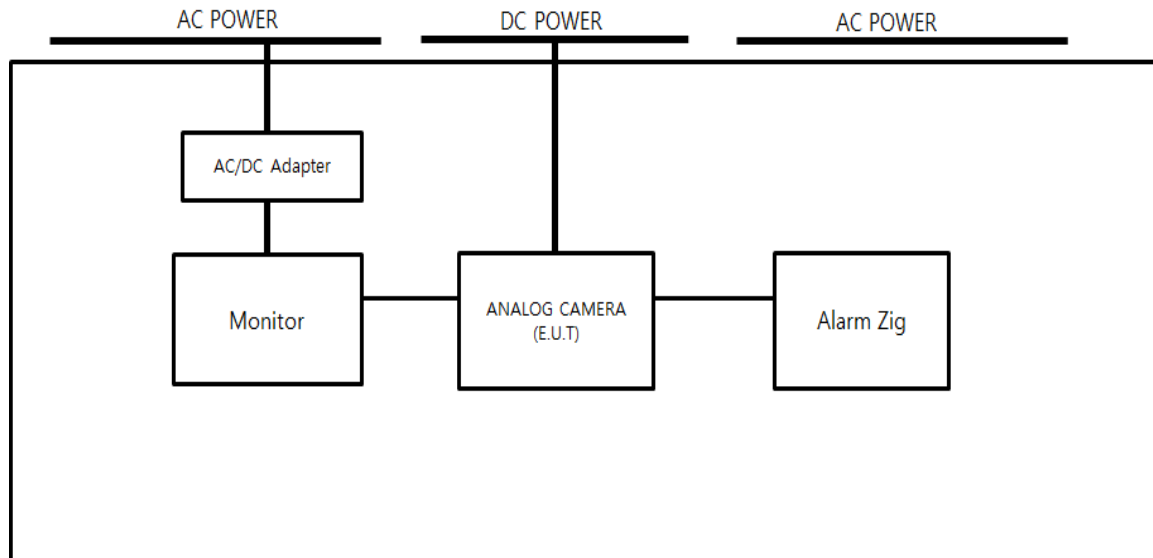

1.9 Operating condition

- Input power condition during the measurements was 24 V (ac), 12 V (dc)
- Monitor Check

2. Product Labelling Requirements

2.1 CE Mark

The CE Conformity Marking must consist of the initials "CE" in the stylized font and proportional to the dimensional requirements shown in following figure. Regardless of its size, the symbol must retain the specified proportionality.

The Various components of the CE Marking must have substantially the same vertical dimensions, and shall not be less than 5mm in height.

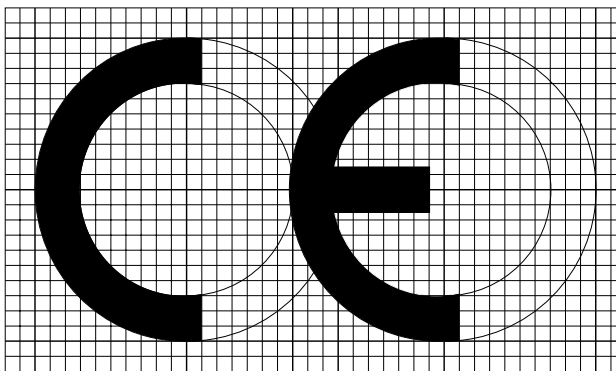

Radius of Outer Circle 100 units
Radius of Inner Circle 70 units
Stroke Width 30 units
Length of Bar 85 units
Axis to Axis 170 units
Minimum Height 5.0 mm

2.2 Statements and User Information

Equipment classification, Class (A)

Directives in which conformance is claimed Applicable EN standards

Transitional provisions Class A equipment shall also include the following statement:

Warning:

This is a Class A product. In a domestic environment this product may cause radio interference in which case the user may be required to take adequate measures.

3. Applicable Regulations

3.1 Emission

EN 55022:2010/CISPR22 are the applicable regulations that apply to Information Technology Equipment. The intention of these standards, is to establish uniform requirements for the radio disturbance level of the equipment contained in the scope, to fix limits of disturbance, to describe method of measurement and to standardize operation conditions and interpretation of the results.

EN 55022:2010/CISPR22 defines Information Technology Equipment (ITE) as follows:

Any equipment which has a primary function of either (or a combination of) entry, storage, display, retrieval, transmission, processing, switching, or control, of data and of telecommunication message and which may be equipped with one or more terminal ports typically operated for information transfer.

Any equipment with a rated supply voltage not exceeding 600 V (ac)

3.2 Immunity

EN 50130-4:2011 Alarm systems-Part 4: Electromagnetic compatibility Product family standard: Immunity requirements for components of fire, intruder and social alarm systems

The variety and the diversity of the apparatus within the scope of this document makes it difficult to define precise criteria for the evaluation of the immunity test results.

If as a result of the application of the tests defined in this standard, the apparatus becomes dangerous or unsafe then the apparatus shall be deemed to have failed the test.

A functional description and a definition of performance by the manufacture and noted in the test report, based on the following criteria:

Electrostatic discharge

There shall be no damage, malfunction or change of status due to the conditioning.

Flickering of an indicator during the application of discharge is permissible, providing that is no residual change in the EUT or any change in outputs, which could be interpreted by associated equipment as a change.

Radiated electromagnetic fields

There shall be no damage, malfunction or change of status due to the conditioning.

Flickering of an indicator during the application of discharge is permissible, providing which could be interpreted by associated equipment as a change, and no such

Flickering of indicators occurs at a field strength of 3 V/m.

For components of CCTV systems, where the picture is allowed at 10 V/m, providing.

- (a) there is no permanent damage or change to EUT
(e.g. no corruption of memory or changes to programmable setting etc.)
- (b) at 3 V/m, any deterioration of the picture is so minor that the system could still be used; and
- (c) there is no observable deterioration of the picture at 1 V/m.

Fast transient burst / slow high energy voltage surge

There shall be no damage, malfunction or change of status due to the conditioning.

Flickering of an indicator during the application of discharge is permissible, providing

That there is no residual is permissible, providing that there is no residual change in the EUT or any change in outputs, which could be interpreted by associated equipment as a change.

Conducted RF immunity

There shall be no damage, malfunction or change of status due to the conditioning.

Flickering of an indicator during the application of discharge is permissible, providing

That there is no residual is permissible, providing that there is no residual change in the EUT or any change in outputs, which could be interpreted by associated equipment as a change,

and no such flickering of indicators occurs at $U = 130 \text{ dB}\mu\text{V}$.

For component of CCTV systems, where the status is monitored by observing the TV picture, then deterioration of the picture is allowed at $U = 140 \text{ dB}\mu\text{V}$, providing:

- (a) there is no permanent damage or change to the EUT
(e.g. no corruption of memory or changes to programmable settings etc.)
- (b) at $U = 130 \text{ dB}\mu\text{V}$, any deterioration of the picture is so minor that the system could still be used; and
- (c) there is no observable deterioration of the picture at $U = 120 \text{ dB}\mu\text{V}$.

Voltage dip/interruption / Voltage variation

There shall be no damage, malfunction or change of status due to the conditioning.

Flickering of an indicator during the conditioning is permissible, providing that there is no residual change in the EUT or any change in outputs, which could be interpreted by associated equipment as a change. The EUT shall meet the acceptance criteria for the functional test, after the conditioning.

4. Test standards and results

STANDARDS		LIMIT	RESULTS
EN 55022	Conducted Emission on AC mains Port	Refer to EN 55022	PASS
	Conducted Emission on Telecommunication Port	Refer to EN 55022	N/A
	Radiated Emission	Refer to EN 55022	PASS
EN 61000-3-2	Harmonic Current Emission on AC Mains Input Port	Refer to EN 61000-3-2	N/A(1)
EN 61000-3-3	Voltage Fluctuations and Flicker on AC Mains Input Port	Refer to EN 61000-3-3	PASS
EN 50130-4	Electrostatic Discharge Immunity	Refer to EN 61000-4-2	PASS
	Radio-frequency electromagnetic field Amplitude modulated Immunity	Refer to EN 61000-4-3	PASS
	Fast Transients Immunity	Refer to EN 61000-4-4	PASS
	Surges Immunity	Refer to EN 61000-4-5	PASS
	Radio-frequency common mode Immunity	Refer to EN 61000-4-6	PASS
	Voltage Dips, Voltage Interruptions Immunity	Refer to EN 61000-4-11	PASS
	Voltage Variations Immunity	Refer to EN 50130-4	PASS

※ Note.

(1) This device is operate by 24 V (ac), 12 V (dc) and, test is not applicable

5. Test Performed

5.1 Conducted Emission Measurements

5.1.1 Test Description

The power line conducted emission measurements were performed in a shielded enclosure. The E.U.T was placed on a wooden table, 80 centimeters height above the floor. Power was fed to the E.U.T through a 50 ohm/ 50 micro henry Line Impedance Stabilization Network (LISN). The ground plane that was electrically bonded to the shield room ground system and all power lines entering the shield room were filtered.

5.1.2 Test Equipments

Description	Manufacturer	Model Number	Serial Number	Cal. Due
EMI Test Receiver	ESR3	R&S	101783	05. 06. 2016
LISN	R&S	ENV216	101137	02. 10. 2016
LISN	R&S	ENV216	101786	05. 06. 2016
Electro wave Shieldroom	SEMITEC	-	-	-

5.1.3 Test Environments

Ambient Temperatures	Relative Humidity
see the data	see the data

5.1.4 Test Limits

- AC Main

Frequency (MHz)	EN 55022			
	Class B (dB μ V)		Class A (dB μ V)	
	Quasi-peak	Average	Quasi-peak	Average
0.15 to 0.50	66.0 to 56.0	56.0 to 46.0	79.0	66.0
0.50 to 5.00	56.0	46.0	73.0	60.0
5.00 to 30.00	60.0	50.0	73.0	60.0

This report shall not be reproduced except in full, without the written approval of KES Co., Ltd.

The results shown in this test report refer only to the sample(s) tested unless otherwise stated.

- Telecommunication

Frequency (MHz)	EN 55022(Voltage)			
	Class B (dB μ V)		Class A (dB μ V)	
	Quasi-peak	Average	Quasi-peak	Average
0.15 to 0.50	84.0 to 74.0	74.0 to 64.0	97.0 to 87.0	84.0 to 74.0
0.50 to 30.00	74.0	64.0	87.0	74.0

Frequency (MHz)	EN 55022(Current)			
	Class B (dB μ A)		Class A (dB μ A)	
	Quasi-peak	Average	Quasi-peak	Average
0.15 to 0.50	40.0 to 30.0	30.0 to 20.0	53.0 to 43.0	40.0 to 30.0
0.50 to 30.00	30.0	20.0	43.0	30.0

5.1.5 Test Procedure

The conducted emission levels were measured on each current-carrying line with the spectrum analyzer operating in the CISPR quasi-peak mode (or peak mode if applicable). The analyzer's 6 dB bandwidth was set to 9 kHz. The initial step in collecting conducted data is a spectrum analyzer peak scan of the measurement range. If the conducted emission exceed the average limit with the instrument set to the quasi-peak mode, the measurements are made in the average mode. The emission spectrum was scanned from 150 kHz to 30 MHz. The highest emission amplitudes relative to the appropriate limits were measured and have been recorded. Quasi-peak readings are distinguished with a "QP".

The conducted emission test was performed with the E.U.T exercise program loaded, and the emissions were scanned between 150 kHz to 30 MHz on the HOT side and NEUTRAL side, herein referred to as H and N, respectively.

5.1.6 Test Results

According to the data in section 5.1.7, the E.U.T complied with the EN 55022/CISPR22 standards.

5.1.7 Test Data

Temperature: 19.4 °C Humidity: 40.1 % R.H. Test Date: 12. 09. 2015 Tested by: Hyo Jin, Kim

- AC POWER Mode

Polarization: HOT

Common Information

Test Description:	Conducted Emission
Model No.:	SCO-6083R
Mode	AC
Operator Name:	KES

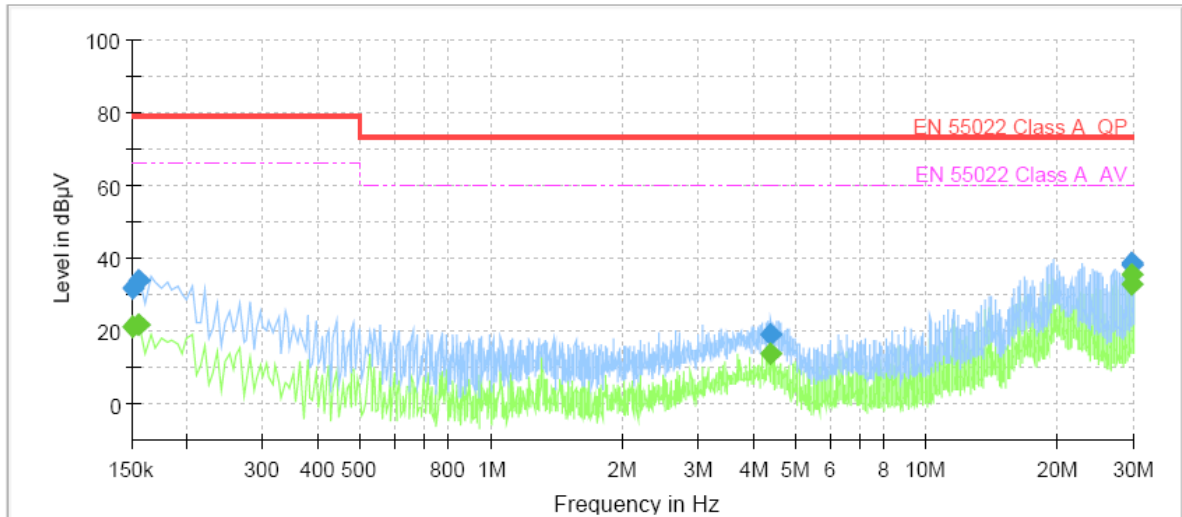

Final Result

Frequency (MHz)	QuasiPeak (dBµV)	CAverage (dBµV)	Limit (dBµV)	Margin (dB)	Meas. Time (ms)	Bandwidth (kHz)	Line	Corr. (dB)
0.150000	---	21.03	66.00	44.97	1000.0	9.000	L1	9.7
0.150000	31.92	---	79.00	47.08	1000.0	9.000	L1	9.7
0.155000	---	21.98	66.00	44.02	1000.0	9.000	L1	9.7
0.155000	33.96	---	79.00	45.04	1000.0	9.000	L1	9.7
4.410000	---	13.95	60.00	46.05	1000.0	9.000	L1	9.8
4.410000	19.11	---	73.00	53.89	1000.0	9.000	L1	9.8
29.625000	---	32.68	60.00	27.32	1000.0	9.000	L1	10.0
29.625000	37.96	---	73.00	35.04	1000.0	9.000	L1	10.0
29.630000	---	35.64	60.00	24.36	1000.0	9.000	L1	10.0
29.630000	38.72	---	73.00	34.28	1000.0	9.000	L1	10.0

This report shall not be reproduced except in full, without the written approval of KES Co., Ltd.

The results shown in this test report refer only to the sample(s) tested unless otherwise stated.

Polarization: NEUTRAL

Common Information

Test Description: Conducted Emission
 Model No.: SCO-6083R
 Mode: AC
 Operator Name: KES

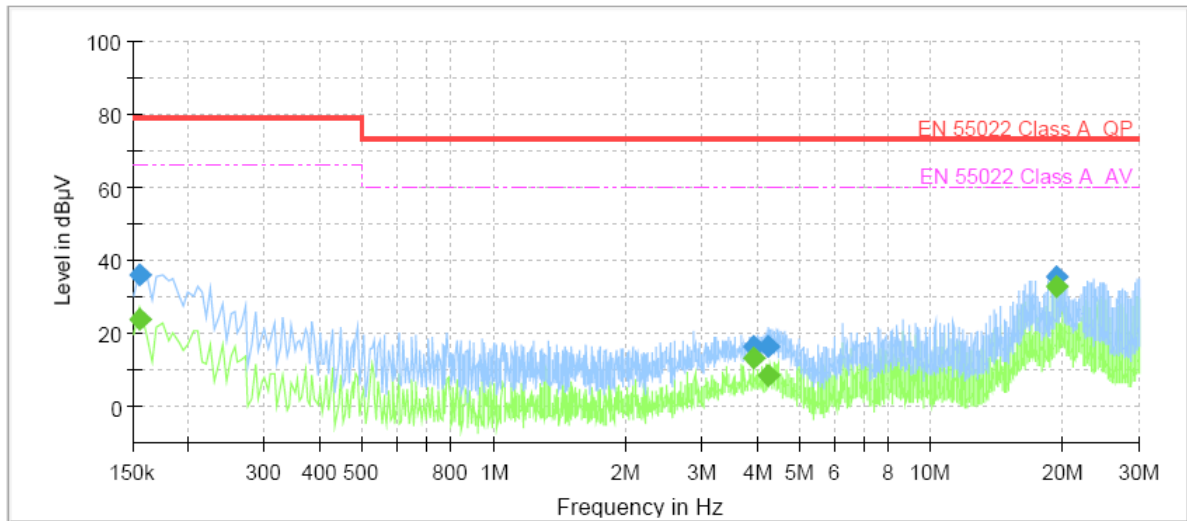

Final Result

Frequency (MHz)	QuasiPeak (dBµV)	CAverage (dBµV)	Limit (dBµV)	Margin (dB)	Meas. Time (ms)	Bandwidth (kHz)	Line	Corr. (dB)
0.155000	---	23.94	66.00	42.06	1000.0	9.000	N	9.6
0.155000	36.21	---	79.00	42.79	1000.0	9.000	N	9.6
3.935000	---	13.04	60.00	46.96	1000.0	9.000	N	9.8
3.935000	16.64	---	73.00	56.36	1000.0	9.000	N	9.8
4.240000	---	8.59	60.00	51.41	1000.0	9.000	N	9.8
4.240000	16.35	---	73.00	56.65	1000.0	9.000	N	9.8
19.410000	---	32.64	60.00	27.36	1000.0	9.000	N	10.0
19.410000	35.49	---	73.00	37.51	1000.0	9.000	N	10.0

This report shall not be reproduced except in full, without the written approval of KES Co., Ltd.

The results shown in this test report refer only to the sample(s) tested unless otherwise stated.



- Telecommunication

Temperature: °C Humidity: % R.H. Test Date: Tested by:

[10 Mbps]

N/A



[100 Mbps]

N/A

5.2 Radiated Emission Measurements

5.2.1 Test Description

The radiated emissions measurements were performed on the ten-meter open-field test site and 3 m full chamber. The E.U.T was placed on a nonconductive turntable approximately 0.8 meters above the ground plane.

The frequency spectrum from 30 MHz to 1 000 MHz and 1 000 MHz to 6 000 MHz was scanned and maximum emission levels at each frequency recorded.

The system was rotated 360°, and the antenna was varied in the height between 1.0 and 4.0 meters in order to determine the maximum emission levels. This procedure was performed for horizontal and vertical polarization of the receiving antenna.

- above 1 GHz : Antenna height is fixed to 1.0 m

* Below 1 GHz

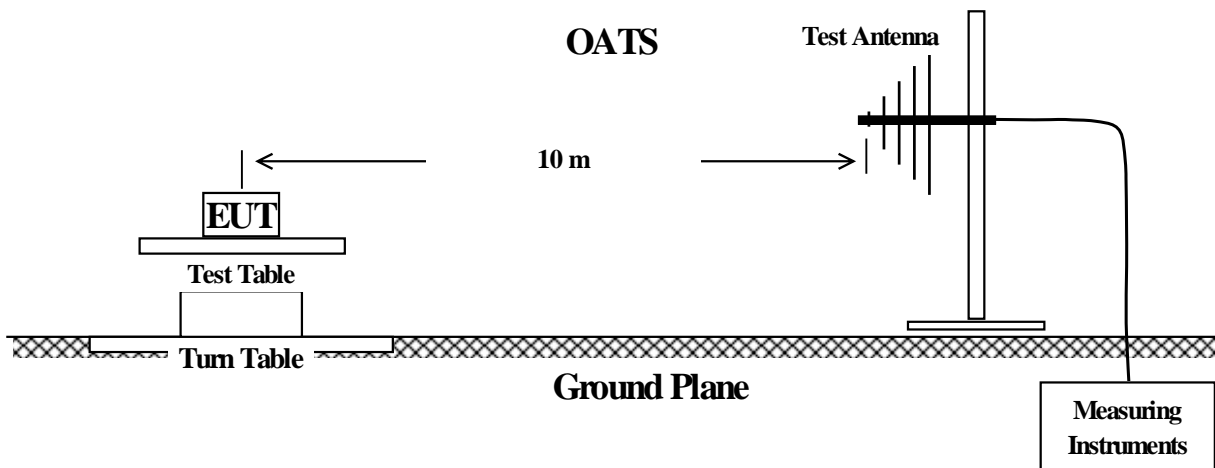

* Above 1 GHz

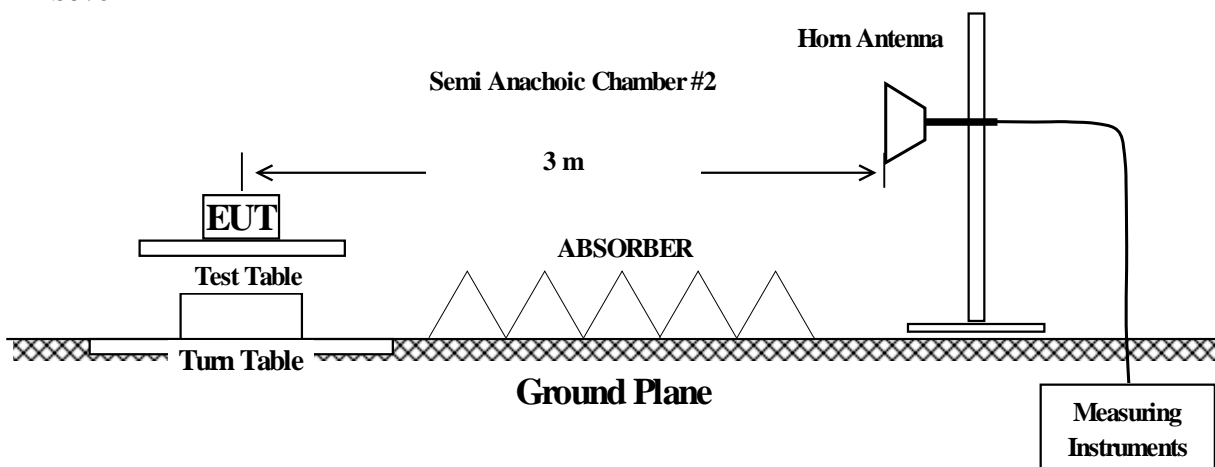

This report shall not be reproduced except in full, without the written approval of KES Co., Ltd.

The results shown in this test report refer only to the sample(s) tested unless otherwise stated.

5.2.2 Test Equipments

Description	Manufacturer	Model Number	Serial Number	Cal. Due
EMI TEST Receiver	R & S	ESR3	101781	05. 06. 2016
Trilog-Broadband Antenna	SCHWARZBECK	VULB 9163	9168-713	05. 15. 2017
OATS	KES	-	-	-
Antenna Mast	DAEIL EMC	-	-	-
Turn Table	DAEIL EMC	-	-	-
EMI TEST Receiver	R & S	ESU26	100552	05. 06. 2016
Broadband Coaxial Preampfier	Schwarzbeck Mess - Elektronik	BBV 9718	9718-246	10. 23. 2016
DOUBLE RIDGED HORN ANTENNA	A.H.SYSTEM,INC	SAS-571	781	05. 07. 2017
Semi Anachoic Chamber #2	SEMITEC	-	-	-
Antenna Mast	AUDIX	-	-	-
Turn Table	AUDIX	-	-	-

5.2.3 Test Environments

Ambient Temperatures	Relative Humidity
see the data	see the data

5.2.4 Test Limits

Frequency (MHz)	EN 55022	
	Class B @ 10 m (dB μ V/m)	Class A @ 10 m (dB μ V/m)
30 to 230	30.0	40.0
230 to 1 000	37.0	47.0

Frequency (MHz)	EN 55022			
	Class B @ 3 m (dB μ V/m)		Class A @ 3 m (dB μ V/m)	
	PK	AV	PK	AV
1 000 to 3 000	70	50	76	56
3 000 to 6 000	74	54	80	60

This report shall not be reproduced except in full, without the written approval of KES Co., Ltd.

The results shown in this test report refer only to the sample(s) tested unless otherwise stated.

5.2.5 Test Procedure

Before final measurements of radiated emission were made on the OATS, the E.U.T was scanned in semi-anechoic chamber in order to determine its emission spectrum signature. The physical arrangement of the test system and associated cabling was varied in order to determine the effect on the E.U.T's emission in amplitude, direction and frequency. This process was repeated during final radiated emission measurements on the OATS range, at each frequency, in order to ensure that maximum emissions amplitudes were attained.

The radiated emission test was performed with E.U.T exercise program loaded, and the emissions were scanned between 30 MHz to 6 000 MHz using the spectrum analyzer. The spectrum analyzer's 6 dB bandwidth was set to 120 kHz(1 MHz), and the analyzer was operated in the CISPR quasi-peak(Peak) detection mode.

Measurements were taken using both HORIZONTAL and VERTICAL antenna polarization, herein referred to as H and V, respectively.

5.2.6 Field Strength Calculation

F.S = Field Strength

M.R = Meter Reading

A.F = Antenna Factor

C.L = Cable Loss

A.G= Amplifier Gain

* Below 1 GHz : $F.S(dB\mu V/m) = M.R(dB\mu V) + [A.F(dB/m) + C.L(dB)]$

* Above 1 GHz : $F.S(dB\mu V/m) = M.R(dB\mu V) + [A.F(dB/m) + C.L(dB)] - A.G$

* Measurement in the presence of high ambient signals

In general, the ambient signals should not exceed the limit. Radiated emanations from the EUT at the point of measurement may, however, be impossible to measure at some frequencies due to ambient noise fields generated by local broadcast services, other manmade devices, and natural sources.

a) Perform measurements at close-in distances and determine the limit L2 corresponding to the close-in distance d2 by applying the following relation:

$$L2 = L1 (d1/d2)$$

where L1 is the specified limit in microvolts per metre ($\mu V/m$) at the distance d1.
Determine the possible environmental and compliance test conditions stipulated in Clause 8 using L2 as the new limit for distance d2.

b) In the frequency bands where the ambient noise values of Clause 8 are exceeded (measured values higher than 6 dB below the limit), the disturbance values of the EUT may be interpolated from the adjacent disturbance values. The interpolated value shall lie on the curve describing a continuous function of the disturbance values adjacent to the ambient noise.

5.2.7 Test Results

According to the data in section 5.2.8, the E.U.T complied with the EN 55022/CISPR22 standards.

5.2.8 Test Data

* Below 1 GHz

- AC POWER Mode

Temperature: 6.6 °C Humidity: 84.0 % R.H. Test Date: 12. 10. 2015 Tested by: Hyo Jin, Kim

Frequency (MHz)	Amplitude (dB μ V)	Antenna		Correction Factor		Corrected Amplitude (dB μ V/m)	Applicable Limit (dB μ V/m)	Margin (dB)
		Polar. (H/V)	Height (m)	Ant. (dB/m)	Cable (dB)			
123.12	12.10	V	1.00	9.38	2.87	24.35	40.00	15.65
133.79	13.27	H	4.00	8.41	3.00	24.68	40.00	15.32
154.16	12.23	V	1.00	8.35	3.24	23.82	40.00	16.18
224.01	14.80	H	3.10	11.83	4.08	30.71	40.00	9.29
446.13	14.30	H	2.86	16.35	6.15	36.80	47.00	10.20
519.85	12.25	H	2.70	17.54	6.74	36.53	47.00	10.47

- DC POWER Mode

Frequency (MHz)	Amplitude (dB μ V)	Antenna		Correction Factor		Corrected Amplitude (dB μ V/m)	Applicable Limit (dB μ V/m)	Margin (dB)
		Polar. (H/V)	Height (m)	Ant. (dB/m)	Cable (dB)			
127.97	12.26	V	1.00	8.94	2.93	24.13	40.00	15.87
134.76	13.31	H	4.00	8.32	3.01	24.64	40.00	15.36
155.13	11.97	V	1.00	8.38	3.25	23.60	40.00	16.40
224.01	17.00	H	3.21	11.83	4.08	32.91	40.00	7.09
446.13	14.09	H	2.89	16.35	6.15	36.59	47.00	10.41
519.85	15.20	H	2.73	17.54	6.74	39.48	47.00	7.52



* Above 1 GHz

- AC POWER Mode

Temperature: 18.9 °C Humidity: 43.1 % R.H. Test Date: 12. 10. 2015 Tested by: Hyo Jin, Kim

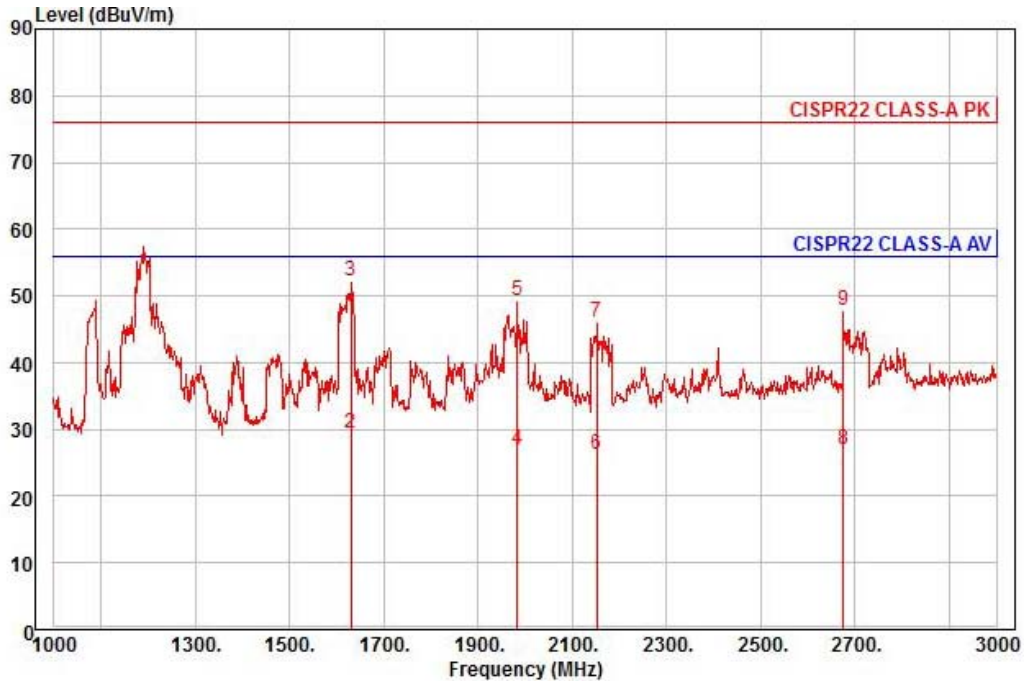

Site : chamber
 Condition: CISPR22 CLASS-A PK 3m HORN781(2015.05.07) horizontal
 : RBW:1000.000kHz VBW:1000.000kHz SWT:Auto
 Project :
 Model : SCO-6083R
 Mode : 24 V (ac)_CE
 Memo : (1 - 3) GHz

	Freq	Read Level	Ant Factor	Cable Loss	Preamp Factor	TPos	Limit Line	Over Limit	Pol/Phase	Remark
	MHz	dBuV	dB/m	dB	dB	deg	dBuV/m	dB		
1	1190.00	0.00	24.66	6.60	40.03	0	76.00	-84.77	horizontal	Peak
2	av 1630.00	34.93	26.41	7.86	39.81	28	56.00	-26.61	horizontal	Average
3	pp 1630.00	57.82	26.41	7.86	39.81	28	76.00	-23.72	horizontal	Peak
4	1984.00	30.00	27.82	8.87	39.64	335	56.00	-28.95	horizontal	Average
5	1984.00	52.30	27.82	8.87	39.64	335	76.00	-26.65	horizontal	Peak
6	2152.00	28.38	28.25	9.34	39.72	346	56.00	-29.75	horizontal	Average
7	2152.00	48.22	28.25	9.34	39.72	346	76.00	-29.91	horizontal	Peak
8	2676.00	26.64	29.54	10.80	40.02	16	56.00	-29.04	horizontal	Average
9	2676.00	47.45	29.54	10.80	40.02	16	76.00	-28.23	horizontal	Peak

This report shall not be reproduced except in full, without the written approval of KES Co., Ltd.

The results shown in this test report refer only to the sample(s) tested unless otherwise stated.

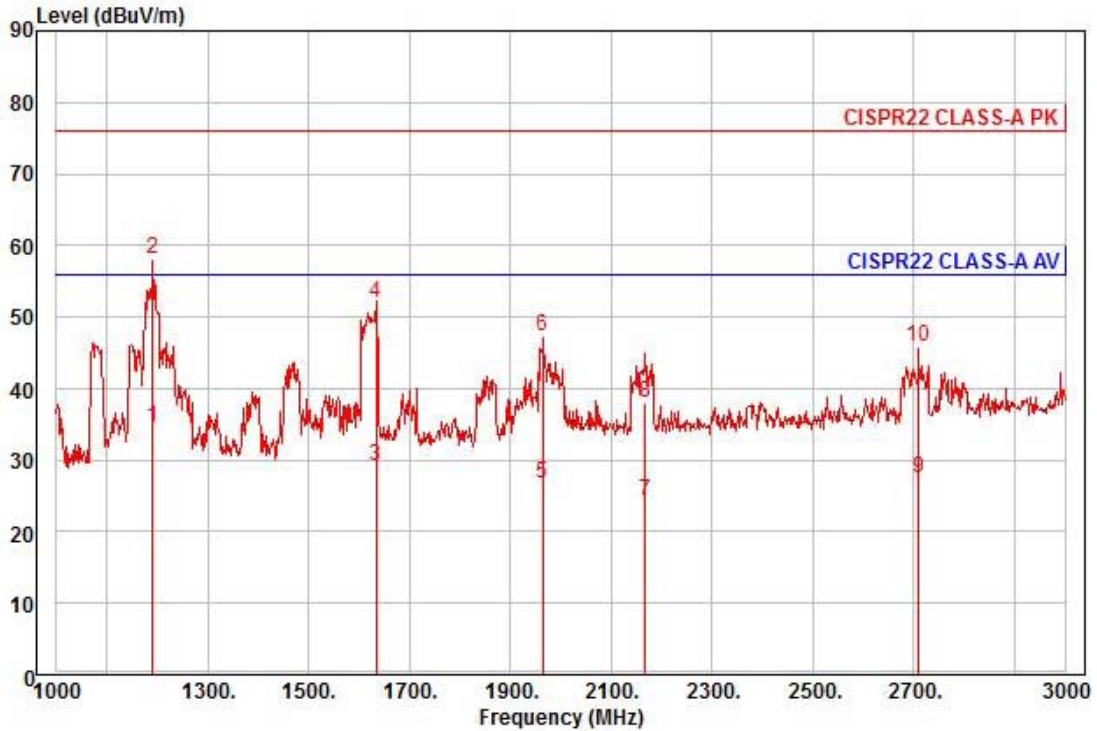

Site : chamber
 Condition: CISPR22 CLASS-A PK 3m HORN781(2015.05.07) vertical
 : RBW:1000.000kHz VBW:1000.000kHz SWT:Auto
 Project :
 Model : SCO-6083R
 Mode : 24 V (ac)_CE
 Memo : (1 - 3) GHz

	Read	Ant	Cable	Preamp	TPos	Limit	Over		
Freq	Level	Factor	Loss	Factor		Line	Limit	Pol/Phase	Remark
MHz	dBuV	dB/m	dB	dB	deg	dBuV/m	dB		
1 av	1190.00	43.44	24.66	6.60	40.03	0	56.00	-21.33	vertical Average
2 pp	1190.00	66.89	24.66	6.60	40.03	0	76.00	-17.88	vertical Peak
3	1634.00	34.70	26.43	7.87	39.81	359	56.00	-26.81	vertical Average
4	1634.00	57.53	26.43	7.87	39.81	359	76.00	-23.98	vertical Peak
5	1964.00	29.93	27.74	8.82	39.65	348	56.00	-29.16	vertical Average
6	1964.00	50.40	27.74	8.82	39.65	348	76.00	-28.69	vertical Peak
7	2168.00	26.30	28.29	9.39	39.73	286	56.00	-31.75	vertical Average
8	2168.00	40.08	28.29	9.39	39.73	286	76.00	-37.97	vertical Peak
9	2710.00	26.98	29.62	10.89	40.04	357	56.00	-28.55	vertical Average
10	2710.00	45.30	29.62	10.89	40.04	357	76.00	-30.23	vertical Peak

This report shall not be reproduced except in full, without the written approval of KES Co., Ltd.

The results shown in this test report refer only to the sample(s) tested unless otherwise stated.

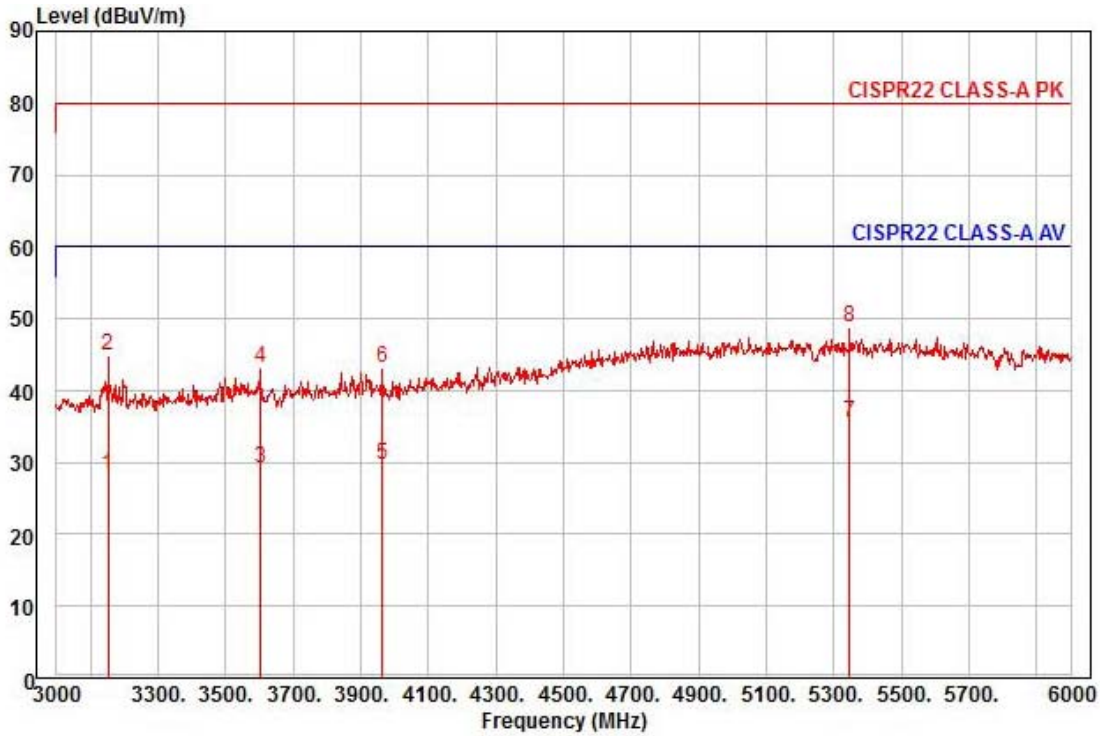

Site : chamber
 Condition: CISPR22 CLASS-A PK 3m HORN781(2015.05.07) horizontal
 : RBW:1000.000kHz VBW:1000.000kHz SWT:Auto
 Project :
 Model : SCO-6083R
 Mode : 24 V (ac)_CE
 Memo : (3 - 6) GHz

	Read Freq	Ant Level	Ant Factor	Cable Loss	Preamplifier Factor	TPos deg	Limit dBuV/m	Over Limit dB	Pol/Phase	Remark
	MHz	dBuV	dB/m	dB	dB	deg	dBuV/m	dB		
1	3153.00	25.86	30.59	11.90	40.24	306	60.00	-31.89	horizontal	Average
2	3153.00	42.61	30.59	11.90	40.24	306	80.00	-35.14	horizontal	Peak
3	3603.00	25.70	31.34	12.50	40.33	7	60.00	-30.79	horizontal	Average
4	3603.00	39.68	31.34	12.50	40.33	7	80.00	-36.81	horizontal	Peak
5	3963.00	25.13	31.95	12.98	40.40	315	60.00	-30.34	horizontal	Average
6	3963.00	38.69	31.95	12.98	40.40	315	80.00	-36.78	horizontal	Peak
7 pp	5346.00	23.43	37.02	15.50	40.36	309	60.00	-24.41	horizontal	Average
8 pk	5346.00	36.54	37.02	15.50	40.36	309	80.00	-31.30	horizontal	Peak

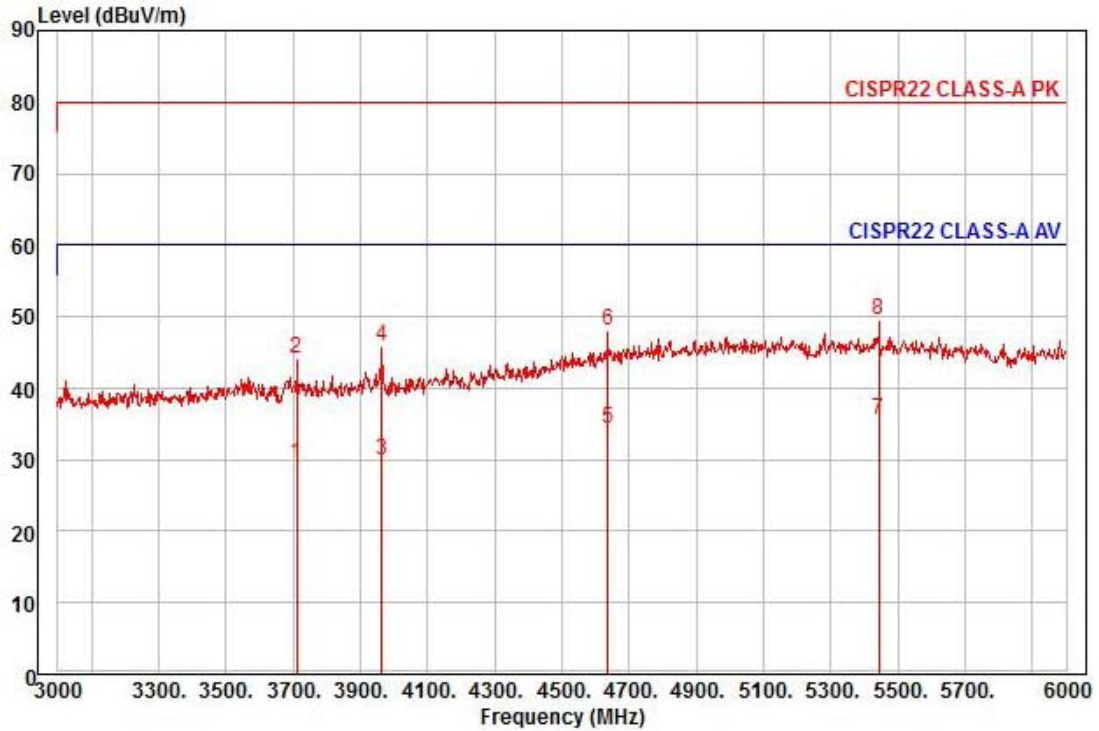

Site : chamber
 Condition: CISPR22 CLASS-A PK 3m HORN781(2015.05.07) vertical
 : RBW:1000.000kHz VBW:1000.000kHz SWT:Auto
 Project :
 Model : SCO-6083R
 Mode : 24 V (ac)_CE
 Memo : (3 - 6) GHz

	Read	Ant	Cable	Preamp	TPos	Limit	Over			
Freq	Level	Factor	Loss	Factor		Line	Limit	Pol/Phase	Remark	
MHz	dBuV	dB/m	dB	dB	deg	dBuV/m	dB			
1	3711.00	25.68	31.52	12.65	40.35	330	60.00	-30.50	vertical	Average
2	3711.00	40.28	31.52	12.65	40.35	330	80.00	-35.90	vertical	Peak
3	3963.00	25.45	31.95	12.98	40.40	338	60.00	-30.02	vertical	Average
4	3963.00	41.33	31.95	12.98	40.40	338	80.00	-34.14	vertical	Peak
5	4638.00	24.88	35.65	14.20	40.41	0	60.00	-25.68	vertical	Average
6	4638.00	38.71	35.65	14.20	40.41	0	80.00	-31.85	vertical	Peak
7 pp	5442.00	23.48	36.83	15.67	40.35	151	60.00	-24.37	vertical	Average
8 pk	5442.00	37.33	36.83	15.67	40.35	151	80.00	-30.52	vertical	Peak

- DC POWER Mode

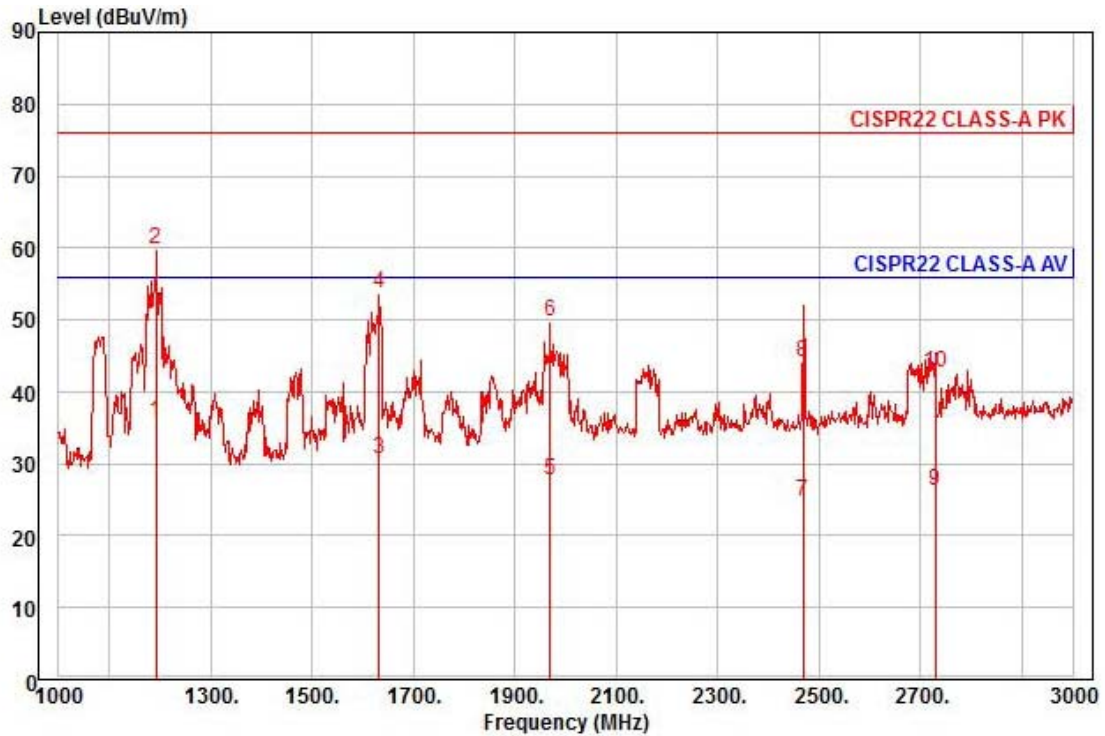

Site : chamber
 Condition: CISPR22 CLASS-A PK 3m HORN781(2015.05.07) horizontal
 : RBW:1000.000kHz VBW:1000.000kHz SWT:Auto
 Project :
 Model : SCO-6083R
 Mode : 12 V (dc)_CE
 Memo : (1 - 3) GHz

	Read	Ant	Cable	Preamp	TPos	Limit	Over		
	Freq	Level	Factor	Loss	Factor	Line	Limit	Pol/Phase	Remark
	MHz	dBuV	dB/m	dB	dB	deg	dBuV/m	dB	
1	av	1192.00	44.54	24.67	6.60	40.03	47	56.00	-20.22 horizontal Average
2	pp	1192.00	68.58	24.67	6.60	40.03	47	76.00	-16.18 horizontal Peak
3		1632.00	36.13	26.42	7.86	39.81	22	56.00	-25.40 horizontal Average
4		1632.00	59.30	26.42	7.86	39.81	22	76.00	-22.23 horizontal Peak
5		1970.00	30.86	27.76	8.83	39.64	24	56.00	-28.19 horizontal Average
6		1970.00	52.95	27.76	8.83	39.64	24	76.00	-26.10 horizontal Peak
7		2468.00	25.32	29.03	10.22	39.90	36	56.00	-31.33 horizontal Average
8		2468.00	44.81	29.03	10.22	39.90	36	76.00	-31.84 horizontal Peak
9		2730.00	25.75	29.67	10.95	40.05	16	56.00	-29.68 horizontal Average
10		2730.00	42.03	29.67	10.95	40.05	16	76.00	-33.40 horizontal Peak

This report shall not be reproduced except in full, without the written approval of KES Co., Ltd.

The results shown in this test report refer only to the sample(s) tested unless otherwise stated.

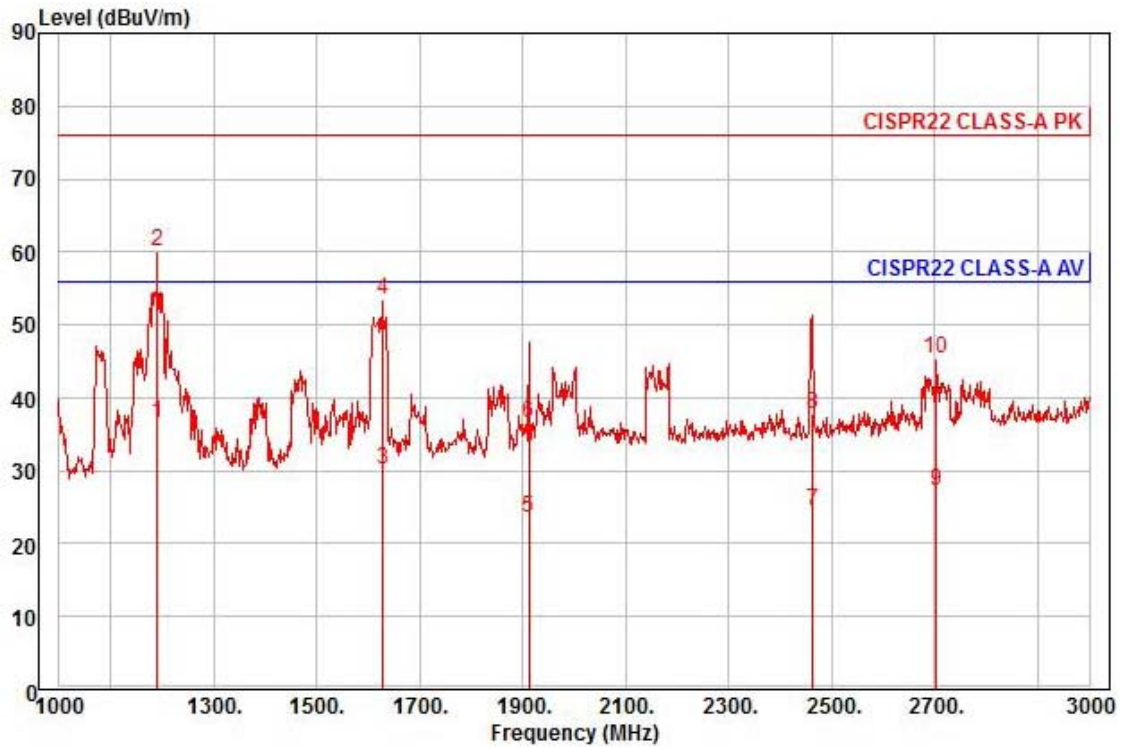

Site : chamber
 Condition: CISPR22 CLASS-A PK 3m HORN781(2015.05.07) vertical
 : RBW:1000.000kHz VBW:1000.000kHz SWT:Auto
 Project :
 Model : SCO-6083R
 Mode : 12 V (dc)_CE
 Memo : (1 - 3) GHz

	Read	Ant	Cable	Preamp	TPos	Limit	Over			
	Level	Factor	Loss	Factor		Line	Limit	Pol/Phase	Remark	
Freq	dBuV	dB/m	dB	dB	deg	dBuV/m	dB			
MHz	dBuV	dB/m	dB	dB	deg	dBuV/m	dB			
1 av	1190.00	45.29	24.66	6.60	40.03	0	56.00	-19.48	vertical	Average
2 pp	1190.00	68.96	24.66	6.60	40.03	0	76.00	-15.81	vertical	Peak
3	1628.00	35.64	26.40	7.85	39.81	11	56.00	-25.92	vertical	Average
4	1628.00	59.04	26.40	7.85	39.81	11	76.00	-22.52	vertical	Peak
5	1912.00	27.02	27.53	8.67	39.67	206	56.00	-32.45	vertical	Average
6	1912.00	40.08	27.53	8.67	39.67	206	76.00	-39.39	vertical	Peak
7	2464.00	25.31	29.02	10.21	39.90	66	56.00	-31.36	vertical	Average
8	2464.00	38.46	29.02	10.21	39.90	66	76.00	-38.21	vertical	Peak
9	2704.00	26.67	29.60	10.88	40.04	356	56.00	-28.89	vertical	Average
10	2704.00	44.92	29.60	10.88	40.04	356	76.00	-30.64	vertical	Peak

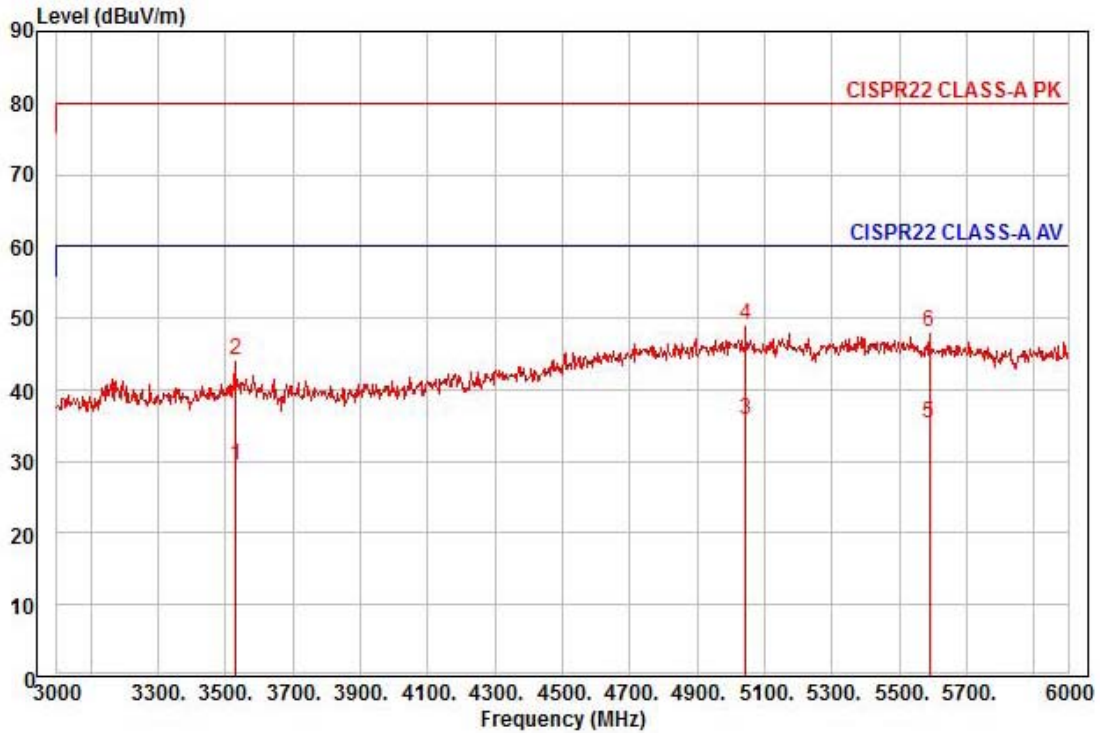

Site : chamber
 Condition: CISPR22 CLASS-A PK 3m HORN781(2015.05.07) horizontal
 : RBW:1000.000kHz VBW:1000.000kHz SWT:Auto
 Project :
 Model : SCO-6083R
 Mode : 12 V (dc)_CE
 Memo : (3 - 6) GHz

	Read Freq	Ant Level	Ant Factor	Cable Loss	Preamp Factor	TPos	Limit Line	Over Limit	Pol/Phase	Remark
	MHz	dBuV	dB/m	dB	dB	deg	dBuV/m	dB		
1	3531.00	26.05	31.22	12.41	40.32	324	60.00	-30.64	horizontal	Average
2	3531.00	40.71	31.22	12.41	40.32	324	80.00	-35.98	horizontal	Peak
3 pp	5043.00	23.63	37.63	14.95	40.40	347	60.00	-24.19	horizontal	Average
4 pk	5043.00	36.91	37.63	14.95	40.40	347	80.00	-30.91	horizontal	Peak
5	5589.00	23.23	36.53	15.94	40.33	312	60.00	-24.63	horizontal	Average
6	5589.00	35.88	36.53	15.94	40.33	312	80.00	-31.98	horizontal	Peak

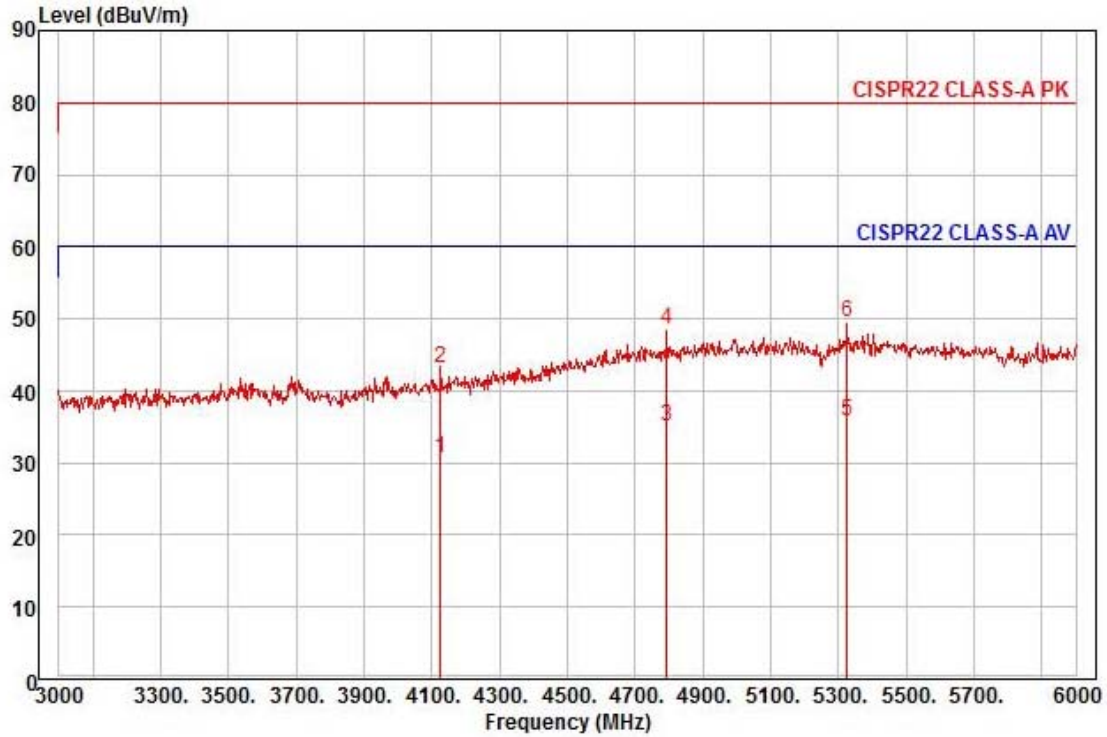

Site : chamber
 Condition: CISPR22 CLASS-A PK 3m HORN781(2015.05.07) vertical
 : RBW:1000.000kHz VBW:1000.000kHz SWT:Auto
 Project :
 Model : SCO-6083R
 Mode : 12 V (dc)_CE
 Memo : (3 - 6) GHz

	Read	Ant	Cable	Preamp	TPos	Limit	Over			
Freq	Level	Factor	Loss	Factor		Line	Limit	Pol/Phase	Remark	
MHz	dBuV	dB/m	dB	dB	deg	dBuV/m	dB			
1	4125.00	24.98	32.72	13.26	40.41	342	60.00	-29.45	vertical	Average
2	4125.00	37.65	32.72	13.26	40.41	342	80.00	-36.78	vertical	Peak
3	4794.00	24.37	36.54	14.49	40.41	184	60.00	-25.01	vertical	Average
4	4794.00	37.86	36.54	14.49	40.41	184	80.00	-31.52	vertical	Peak
5 pp	5325.00	23.68	37.06	15.46	40.36	153	60.00	-24.16	vertical	Average
6 pk	5325.00	37.35	37.06	15.46	40.36	153	80.00	-30.49	vertical	Peak

5.3 Harmonics / Voltage Fluctuations Measurements

5.3.1 Test Description

Harmonics of the fundamental current were measured up to 2 kHz using a universal power analyzer. The measurements were carried out under steady conditions and using averaging.

Before making measurements the class of the E.U.T has been evaluated, it is necessary for the E.U.T to decide which class the E.U.T fulfills into; A, B, C or D

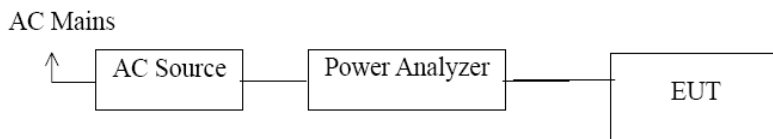

5.3.2 Test Equipments

Description	Manufacturer	Model Number	Serial Number	Cal. Due
AC Source	EM test	ACS 500 N	V1024106760	08. 13. 2016
Digital Power Analyzer	EM test	DPA 500 N	V1024106759	08. 13. 2016

5.3.3 Test Environments

Ambient Temperatures : see the data

Relative Humidity : see the data

5.3.4 Test Procedures

The E.U.T was installed and placed on a non-conductive table and was connected to the AC power source, 230 V (ac), 50 Hz via the measuring equipment with its attached AC power cord. All other equipment or peripherals included in the test, and having a separate power supply, are connected to the outlet, supplying 230 V (ac), 50 Hz. A typical configuration is defined in the specification ANSI 63.4 or CISPR22. This ensures the repeatability of the test.

The E.U.T is set in operation and was monitored for measurements with the software, supplied by test equipment manufacturer. An EMC test program provided by client was used to exercise the E.U.T.



5.3.5 Test Results

Harmonic test is not applicable,
According to the data in section 5.3.7 the EUT complied with the EN61000-3-3:2013 standards, and detailed test results are found in the following test data.

5.3.6 Test Data - Homonic

Temperature: °C Humidity: % R.H. Test Date: Tested by:

Average harmonic current results				
Hn	I _{eff} [A]	% of Limit	Limit [A]	Result
1	N/A			
2				
3				
4				
5				
6				
7				
8				
9				
10				
11				
12				
13				
14				
15				
16				
17				
18				
19				
20				
21				
22				
23				
24				
25				
26				
27				
28				
29				
30				
31				
32				
33				
34				
35				
36				
37				
38				
39				
40				

This report shall not be reproduced except in full, without the written approval of KES Co., Ltd.

The results shown in this test report refer only to the sample(s) tested unless otherwise stated.



Test Data - Harmonics (continued)

<i>Maximum harmonic Current results</i>				
Hn	I _{eff} [A]	% of Limit	Limit [A]	Result
1	N/A			
2				
3				
4				
5				
6				
7				
8				
9				
10				
11				
12				
13				
14				
15				
16				
17				
18				
19				
20				
21				
22				
23				
24				
25				
26				
27				
28				
29				
30				
31				
32				
33				
34				
35				
36				
37				
38				
39				
40				

This report shall not be reproduced except in full, without the written approval of KES Co., Ltd.

The results shown in this test report refer only to the sample(s) tested unless otherwise stated.

5.3.7 Test Data - Voltage Fluctuations**- AC POWER Mode**

Temperature: 19.4 °C Humidity: 40.1 % R.H. Test Date: 12. 09. 2015 Tested by: Hyo Jin, Kim

Maximum Flicker results

	E.U.T values	Limit	Result
Pst	0.028	1.00	PASS
Plt	0.028	0.65	PASS
dc [%]	0.000	3.30	PASS
dmax [%]	0.036	4.00	PASS
dt [s]	0.000	0.50	PASS

5.4 Electrostatic Discharge Immunity

5.4.1 Test Description

The E.U.T and all local support equipment were placed on non-metallic support 0.8 m above a reference ground plane (RGP) and was put into operation according to the specified operating mode.

5.4.2 Test Equipments

Description	Manufacturer	Model Number	Serial Number	Cal. Due
ESD SIMULATOR	Noise Ken	ESS-2000	ESS05X4620	06. 30. 2016

5.4.3 Test Environment

Ambient Temperatures :	15 °C ~ 35 °C
Relative Humidity :	25 % R.H. ~ 75 % R.H.
Atmospheric Pressure :	86.0 kPa ~ 106.0 kPa

5.4.4 Test Levels

Discharge Impedance :	330 Ω ± 10 % / 150 pF ± 10 %
Type of Discharge :	Direct - Air Discharge (± 2 kV & ± 4 kV & ± 8 kV), Contact Discharge (± 6 kV) Indirect - HCP Discharge (± 2 kV & ± 4 kV & ± 6 kV) VCP Discharge (± 2 kV & ± 4 kV & ± 6 kV)
Polarity of Output Voltage :	Positive and Negative
Discharge Repetition Rate :	1/sec
Number of Discharges :	more than 10 times
Performance Criteria :	B

5.4.5 Test Procedure

Test programs and software were chosen so as to exercise all normal modes of operation of the E.U.T. The use of special exercising software is encouraged, but permitted only where it can be shown that the E.U.T is being comprehensively exercised.

The test was conducted in the following order: Air Discharge, Direct Contact Discharge, Indirect Contact Horizontal Coupling Plane (HCP) Discharge, and Indirect Contact Vertical Coupling Plane (VCP) Discharge. The electrostatic discharge test levels were set and discharges for the different test modes were set appropriately. The electrostatic discharge is applied to the conductive surface of the E.U.T, and along all seams and control surfaces on the E.U.T. When a discharge occurs and an error is caused, the type of error, discharge level and location is recorded.

5.4.6 Test Results

According to the data in section 5.4.7, the E.U.T complied with the EN61000-4-2 standards, and detailed test results are found in the following test data.

5.4.7 Test Data

- AC POWER Mode

Temperature: 19.4 °C Humidity: 40.1 % R.H. Test Date: 12. 09. 2015 Tested by: Hyo Jin, Kim

Indirect Discharge

No.	Test Point	Discharge Method	Performance	Remarks
			Results	
1	HCP Contact	Contact Discharge	Complied	-
2	VCP Contact	Contact Discharge	Complied	-

Direct Discharge

No.	Test Point	Discharge Method	Performance	Remarks
			Results	
1	Enclosure 1	Contact Discharge	Complied	-
2	Enclosure 2	Contact Discharge	Complied	-
3	Enclosure 3	Contact Discharge	Complied	-
4	Port	Contact Discharge	Complied	-

10 times Indirect discharge test for each polarity.



- DC POWER Mode

Indirect Discharge

No.	Test Point	Discharge Method	Performance	Remarks
			Results	
1	HCP Contact	Contact Discharge	Complied	-
2	VCP Contact	Contact Discharge	Complied	-

Direct Discharge

No.	Test Point	Discharge Method	Performance	Remarks
			Results	
1	Enclosure 1	Contact Discharge	Complied	-
2	Enclosure 2	Contact Discharge	Complied	-
3	Enclosure 3	Contact Discharge	Complied	-
4	Port	Contact Discharge	Complied	-

10 times Indirect discharge test for each polarity.

5.5 Radio-frequency electromagnetic field Amplitude modulated Immunity

5.5.1 Test Description

The E.U.T and all local support equipment were placed on a non-metallic support 0.8 m above a reference ground plane (RGP) and was put into operation according to the specified operating mode.

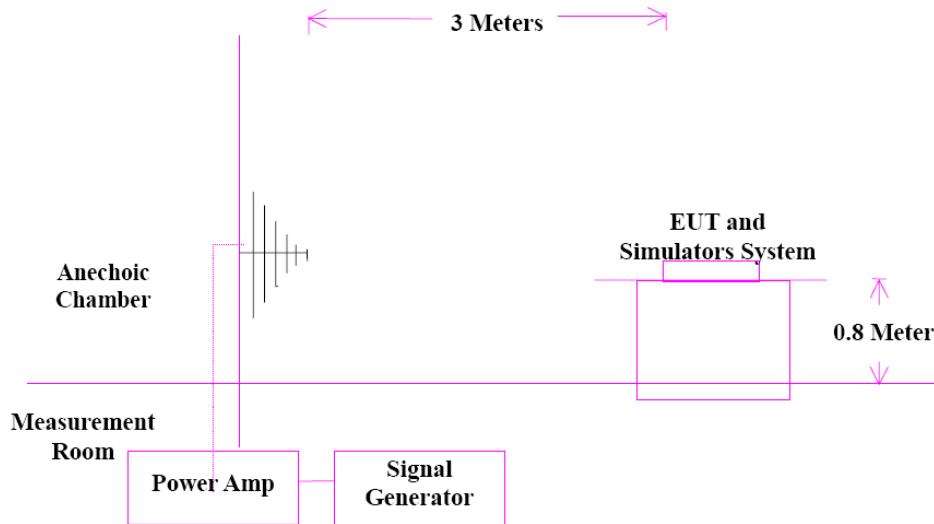

5.5.2 Test Equipments

Description	Manufacturer	Model Number	Serial Number	Cal. Due
SUGNAL GENERATOR	Rohde & Schwarz	SMB 100A	108252	08. 13. 2016
BROADBAND AMPLIFIER	Rohde & Schwarz	BBA100	101239	08. 13. 2016
BROADBAND AMPLIFIER	AR	100S1G6M1	579931	08. 13. 2016
POWER METER	Rohde & Schwarz	NRP2	103475	08. 13. 2016
AVG POWER SENSOR	Rohde & Schwarz	NRP-Z91	102526	08. 13. 2016
AVG POWER SENSOR	Rohde & Schwarz	NRP-Z91	102527	08. 13. 2016
Stacked Log.-Per.Antenna	Schwarzbeck	STLP 9128 D	9128D038	-
Semi Anachoic Chamber #2	SEMITEC	-	-	-

This report shall not be reproduced except in full, without the written approval of KES Co., Ltd.

The results shown in this test report refer only to the sample(s) tested unless otherwise stated.

5.5.3 Test Environments

Ambient Temperatures :	15 °C ~ 35 °C
Relative Humidity :	25 % R.H. ~ 75 % R.H.
Atmospheric Pressure :	86.0 kPa ~ 106.0 kPa

5.5.4 Test Levels

Frequency Range :	80 MHz to 2 700 MHz
Field Strength :	10 V/m(3 V/m, 1 V/m)
Modulation :	80 % Amplitude Modulation (1 kHz) Pulse Modulation (1 Hz (0.5 s ON: 0.5 s OFF))
Distance of ANT-E.U.T :	3 meters
Antenna Polarity :	Horizontal and Vertical
Frequency Step :	1 %
Performance Criteria :	A

5.5.5 Test Procedures

The E.U.T is set into operation and was monitored for variations in performance. The test signal start frequency (80 MHz) and stop frequency (2 700 MHz) were set, including the field strength at 10 V/m(3 V/m, 1 V/m), 80 % modulated through immunity test software. The software maintains the necessary field strength through the frequency range, with the transmitting antenna horizontally polarized. If an error is detected, the field is reduced until the error is not repeatable, the field is then manually increased until the error begins to occur. This threshold level, the frequency and the error created are noted before continuing. The test is then repeated with vertical polarization, using the same test configuration for all four sides.

5.5.6 Test Results

According to the data in section 5.5.7, the E.U.T complied with the EN 61000-4-3 standards, and detailed test results are found in the following test data.

5.5.7 Test Data

- AC POWER Mode

Temperature: 18.9 °C Humidity: 43.1 % R.H. Test Date: 12. 10. 2015 Tested by: Hyo Jin, Kim

No.	Test Point	Performance Results		Remarks
		Horizontal	Vertical	
1	Front	Complied	Complied	-
2	Rear	Complied	Complied	-
3	Right Side	Complied	Complied	-
4	Left Side	Complied	Complied	-

- DC POWER Mode

No.	Test Point	Performance Results		Remarks
		Horizontal	Vertical	
1	Front	Complied	Complied	-
2	Rear	Complied	Complied	-
3	Right Side	Complied	Complied	-
4	Left Side	Complied	Complied	-

This report shall not be reproduced except in full, without the written approval of KES Co., Ltd.

The results shown in this test report refer only to the sample(s) tested unless otherwise stated.

5.6 Fast Transient Immunity

5.6.1 Test Description

The E.U.T and all local support equipment were placed a non-metallic support 0.8 m above a reference ground plane (RGP) and was put into operation according to the specified operating mode. If the E.U.T has a non-detachable supply cable more than 1 m long, the excess length of this cable was gathered into a flat coil with a 0.4 m diameter and situated at a distance of 0.1 m above the RGP.

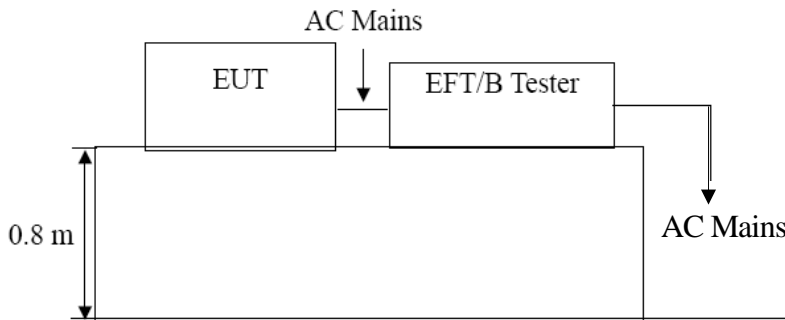

5.6.2 Test Equipments

Description	Manufacturer	Model Number	Serial Number	Cal. Due
Ultra Compact Simulator	EMC TEST	UCS 500 N5	V0936105120	07. 14. 2016
Motorized Variac	EMC TEST	MV2616	V0936105123	07. 14. 2016
Capacitive Coupling Clamp	EMC TEST	HFK	070925	07. 14. 2016

5.6.3 Test Environments

Ambient Temperatures : 15 °C ~ 35 °C
 Relative Humidity : 25 % R.H. ~ 75 % R.H.
 Atmospheric Pressure : 86.0 kPa ~ 106.0 kPa

This report shall not be reproduced except in full, without the written approval of KES Co., Ltd.

The results shown in this test report refer only to the sample(s) tested unless otherwise stated.

5.6.4 Test Levels

Open Circuit Output Test Voltage :	■ Power Supply AC; ± 2 kV ■ Power Supply DC; ± 1 kV ■ I/O Signal, Data and Control ports; ± 1 kV
Repetition Frequency of the Impulses :	100 kHz
Polarity :	Positive and Negative
Rise Time of One Pulse :	5 ns ± 30 %
Impulse Duration :	50 ns ± 30 %
Burst Duration :	15 ms ± 20 %
Burst Period :	300 ms ± 20 %
Performance Criteria :	B

5.6.5 Test Procedure

The E.U.T was connected to the test equipment, and monitored for performance. The test level was set and the test signal was applied for 200 seconds. A test signal of ± 1 kV, and ± 2 kV was Coupled to Line and Ground, Neutral and Ground, Line plus Neutral and Ground, and Protective Earth and Ground. When an error occurs, the test level is reduced until the error recovers and then increased until the threshold level is reached. This threshold and the error conditions were noted. This procedure was then repeated for the other coupling modes.

5.6.6 Test Results

According to the data in section 5.6.7, the EUT complied with the EN61000-4-4 standards, and detailed test results are found in the following test data.

5.6.7 Test Data

- AC POWER Mode

Temperature: 19.2°C Humidity: 41.3 % R.H. Test Date: 12. 11. 2015 Tested by: Hyo Jin, Kim

On AC Power Supply

No.	Test Point	Performance Results		Remarks
		+Burst	-Burst	
1	L1	Complied	Complied	-
2	L2	Complied	Complied	-
3	PE	-	-	-
4	L1-L2	Complied	Complied	-
5	L1-PE	-	-	-
6	L2-PE	-	-	-
7	L1-L2-PE	-	-	-

On DC Power Supply

No.	Test Point	Performance Results		Remarks
		+Burst	-Burst	
-	-	-	-	-
-	-	-	-	-
-	-	-	-	-

On I/O Signal, Data and Control ports

No.	Test Point	Performance Results		Remarks
		+Burst	-Burst	
1	Alarm Out	Complied	Complied	-
2	BNC	Complied	Complied	-

This report shall not be reproduced except in full, without the written approval of KES Co., Ltd.

The results shown in this test report refer only to the sample(s) tested unless otherwise stated.

- DC POWER Mode

On AC Power Supply

No.	Test Point	Performance Results		Remarks
		+Burst	-Burst	
1	L1	Complied	Complied	-
2	L2	Complied	Complied	-
3	PE	-	-	-
4	L1-L2	Complied	Complied	-
5	L1-PE	-	-	-
6	L2-PE	-	-	-
7	L1-L2-PE	-	-	-

On DC Power Supply

No.	Test Point	Performance Results		Remarks
		+Burst	-Burst	
1	L1	Complied	Complied	-
2	L2	Complied	Complied	-
3	L1-L2	Complied	Complied	-

On I/O Signal, Data and Control ports

No.	Test Point	Performance Results		Remarks
		+Burst	-Burst	
1	Alarm Out	Complied	Complied	-
2	BNC	Complied	Complied	-

This report shall not be reproduced except in full, without the written approval of KES Co., Ltd.

The results shown in this test report refer only to the sample(s) tested unless otherwise stated.

5.7 Surge Immunity

5.7.1 Test Description

The E.U.T and all local support equipment was placed on a non-metallic support 0.8 m above a reference ground plane (RGP) and was put into operation according to the specified operating mode.

5.7.2 Test Equipments

Description	Manufacturer	Model Number	Serial Number	Cal. Due
Ultra Compact Simulator	EM TEST	UCS 500 N5	V0936105120	07. 14. 2016
MotorVariac	EM TEST	MV2616	V0936105123	07. 14. 2016
CDN	EM TEST	CNV 504N	V0936105121	-

5.7.3 Test Environments

Ambient Temperatures :	15 °C ~ 35 °C
Relative Humidity :	25 % R.H. ~ 75 % R.H.
Atmospheric Pressure :	86.0 kPa ~ 106.0 kPa

5.7.4 Test Levels

Open Circuit Test Voltage :	<input checked="" type="checkbox"/> AC Power; ± 0,5 kV & ± 1 kV line-to-line, <input checked="" type="checkbox"/> AC Power, ± 0,5 kV & ± 1 kV & ± 2 kV line-to-ground <input type="checkbox"/> DC Power; ± 0,5 kV & ± 1 kV line-to-ground <input checked="" type="checkbox"/> Data and Control Line; ± 0,5 kV & ± 1 kV line-to-ground
Open Circuit Voltage Waveform :	1.2/50 microsecond
Short Circuit Current Waveform :	8/20 microsecond
Number of Tests :	5 positive and 5 negative
Repetition Rate :	1/min
Performance Criteria :	B

5.7.5 Test Procedure

The surges have to be applied line to line and line(s) and ground. In case of testing line to ground the test voltage has to be applied successively between each of the lines and ground, if there is no other specification. All lower levels including the selected test level must be satisfied. For testing the secondary protection the output voltage of the generator must be increased up to the worst case voltage break down level of the primary protection.

5.7.6 Test Results

According to the data in section 5.7.7, the E.U.T complied with the EN61000-4-5 standards, and detailed test results are found in the following test data.

5.7.7 Test Data

- AC POWER Mode

Temperature: 19.2 °C Humidity: 41.3 % R.H. Test Date: 12. 11. 2015 Tested by: Hyo Jin, Kim

On AC Power Supply

No.	Test Point	Performance Results		Remarks
		+Surge	-Surge	
1	L1-L2	Complied	Complied	-
2	L1-PE	-	-	-
3	L2-PE	-	-	-

On I/O Signal, Data and Control ports

No.	Test Point	Performance Results		Remarks
		+Surge	+Surge	
1	Alarm Out	Complied	Complied	-
2	BNC	Complied	Complied	-

- DC POWER Mode

On AC Power Supply

No.	Test Point	Performance Results		Remarks
		+Surge	-Surge	
1	L1-L2	-	-	-
2	L1-PE	-	-	-
3	L2-PE	-	-	-

On I/O Signal, Data and Control ports

No.	Test Point	Performance Results		Remarks
		+Surge	+Surge	
1	Alarm Out	Complied	Complied	-
2	BNC	Complied	Complied	-

5.8 Radio-frequency continuous conducted Immunity

5.8.1 Test Descriptions

The E.U.T and all local support equipment were placed on a non-metallic support 0.1 m above a reference ground plane (RGP) and was put into operation according to the specified operating mode.

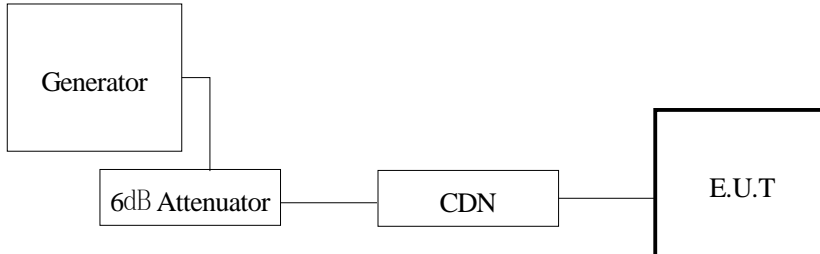

5.8.2 Test Equipments

Description	Manufacturer	Model Number	Serial Number	Cal. Due
Continuous Wave Simulator	EM TEST	CWS 500N1	P1251106910	04. 01. 2016
6dB Attenuator	EM TEST	ATT6	1208-34	08. 13. 2016
CDN	EM TEST	CDN-M2/M3N	0909-06	08. 13. 2016
EM Injection Clamp	EM TEST	EM 101	35943	02. 11. 2016

5.8.3 Test Environments

Ambient Temperatures :	15 °C ~ 35 °C
Relative Humidity :	25 % R.H. ~ 75 % R.H.
Atmospheric Pressure :	86.0 kPa ~ 106.0 kPa

5.8.4 Test Levels

Frequency Range :	150 kHz to 100 MHz
Voltage Level :	10 V(3 V, 1 V)
Modulation :	80 % Amplitude Modulation (1 kHz) Pulse Modulation (1 Hz (0.5 s ON: 0.5 s OFF))
Frequency Step :	1 %
Performance Criteria :	A

This report shall not be reproduced except in full, without the written approval of KES Co., Ltd.

The results shown in this test report refer only to the sample(s) tested unless otherwise stated.

5.8.5 Test Procedure

The test was performed with the test generator connected to each of the coupling and decoupling devices in turn while the other non-excited RF-input ports of the coupling devices are terminated by a 50 Ω load resistor. The frequency range is swept from 150 kHz to 100 MHz, using the signal levels established during the setting process, and with the disturbance signal 80 % amplitude modulated with a 1kHz sine wave, pausing to adjust the RF-signal level or to switch coupling device as necessary.

5.8.6 Test Results

According to the data in section 5.8.7, the E.U.T complied with the EN61000-4-6 standards, and detailed test results are found in the following test data.

5.8.7 Test Data

- AC POWER Mode

Temperature: 19.2 °C Humidity: 41.3 % R.H. Test Date: 12. 11. 2015 Tested by: Hyo Jin, Kim

On AC Power Supply

No.	Test Point	Performance		Remarks
		Coupling method	Results	
1	CDN-M2/M3N	CDN	Complied	CDN-M2

On DC Power Supply

No.	Test Point	Performance		Remarks
		Coupling method	Results	
1	-	-	-	-

On I/O Signal, Data and Control ports

No.	Test Point	Performance Results		Remarks
		Coupling method	Coupling method	
1	Alarm Out	Complied	Complied	-
2	BNC	Complied	Complied	-



- DC POWER Mode

On AC Power Supply

No.	Test Point	Performance		Remarks
		Coupling method	Results	
1	-	-	-	-

On DC Power Supply

No.	Test Point	Performance		Remarks
		Coupling method	Results	
1	CDN-M2/M3N	CDN	Complied	CDN-M2

On I/O Signal, Data and Control ports

No.	Test Point	Performance Results		Remarks
		Coupling method	Coupling method	
1	Alarm Out	Complied	Complied	-
2	BNC	Complied	Complied	-

5.9 Voltage Dips and Voltage Interruptions Immunity Measurements

5.9.1 Test Descriptions

The E.U.T and all local support equipment was placed on a non-metallic support 0.8 m above a reference ground plane (RGP) and was put into operation according to the specified operating mode.

5.9.2 Test Equipments

Description	Manufacturer	Model Number	Serial Number	Cal. Due
Ultra Compact Simulator	EM TEST	UCS 500 N5	V0936105120	07. 14. 2016
MotorVariac	EM TEST	MV2616	V0936105123	07. 14. 2016

5.9.3 Test Environments

Ambient Temperatures :	15 °C ~ 35 °C
Relative Humidity :	25 % R.H. ~ 75 % R.H.
Atmospheric Pressure :	86.0 kPa ~ 106.0 kPa

5.9.4 Test Levels

Overshoot/Undershoot of Actual Voltage :	Less than ± 5 % of the change in voltage
Voltage Rise and Fall Time :	Between 1 and 5 microseconds
Test Voltage / Test Frequency :	230 V (ac) / 50 Hz
Frequency Deviation of Test Voltage :	Less than ± 2 % of rated frequency
Number of Tests :	3 times
Test Intervals :	10 sec
Performance Criteria :	B for Voltage Dips C for Voltage Short Interruptions A for Voltage Variation

5.9.5 Test Procedure

For each test any degradation of performance were recorded. The monitoring equipment should be capable of displaying the status of the operational mode of the E.U.T during and after the tests. After each group of tests a full functional check were performed.

5.9.6 Test Results

According to the data in section 5.9.7, the E.U.T complied with the EN61000-4-6 standards, and detailed test results are found in the following test data.

5.9.7 Test Data

Temperature: 19.2 °C Humidity: 41.3 % R.H. Test Date: 12. 11. 2015 Tested by: Hyo Jin, Kim

Voltage Dips(AC Power Supply)

No.	Depth	Duration	Results	Remarks
1	20 %	250T	Complied	-
2	30 %	25T	Complied	-
3	60 %	10T	Complied	-
4	100 %	250T	Complied(Note)	-

Voltage variations(AC Power Supply)

No.	Test Level		Results	Remarks
1	Unom + 10 %	253 V (ac)	Complied	-
2	Unom - 15 %	195.5 V (ac)	Complied	-

- Note : The Power of EUT is off during the test. After the test , EUT is getting back to normal operation.

6. Test Setup Photographs

6.1 Conducted Emission

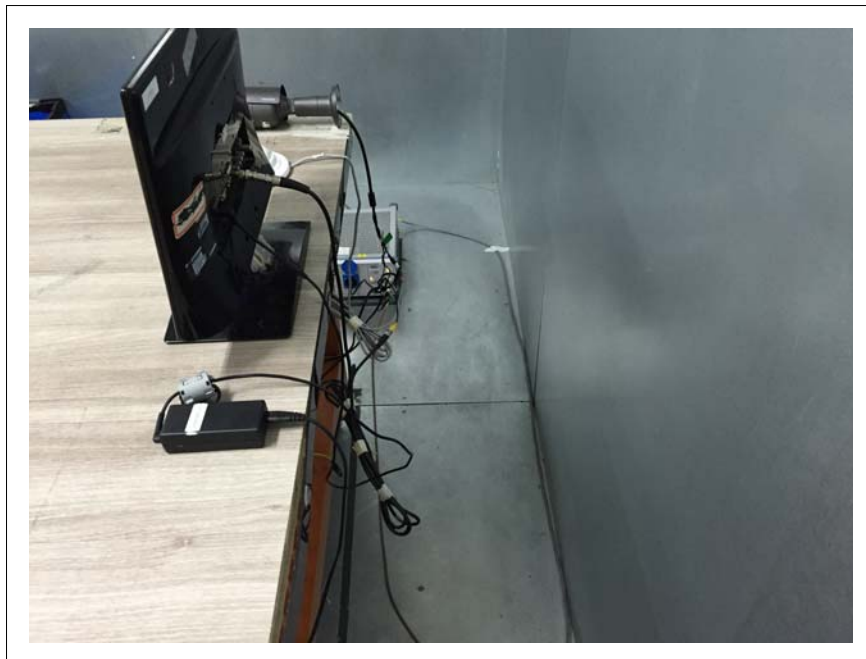
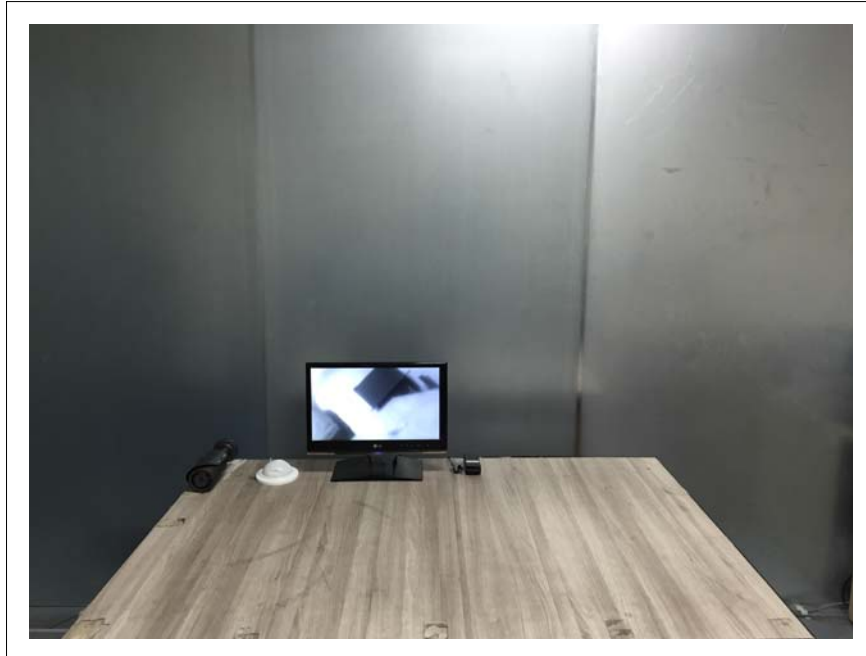

This report shall not be reproduced except in full, without the written approval of KES Co., Ltd.

The results shown in this test report refer only to the sample(s) tested unless otherwise stated.

- **Telecommunication Emission**

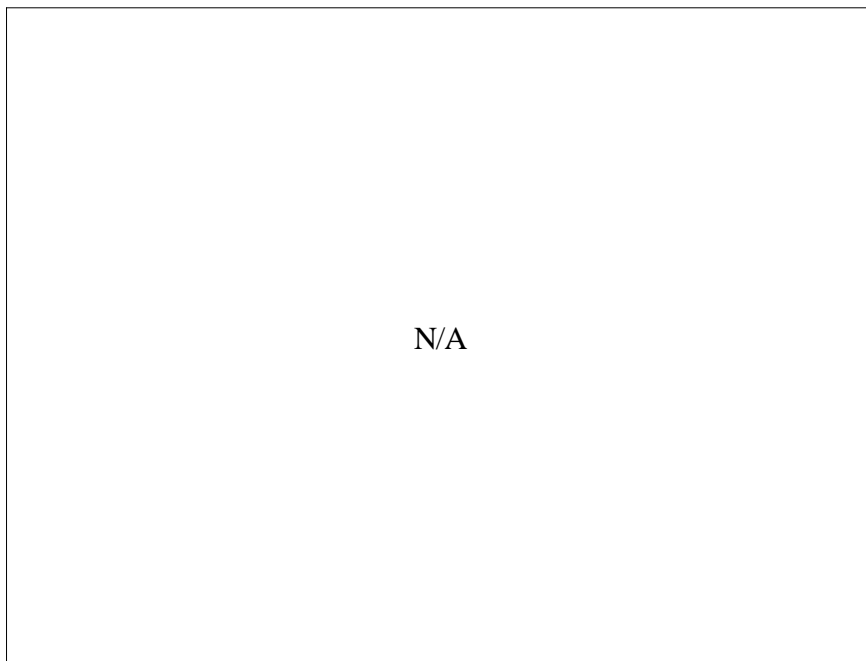
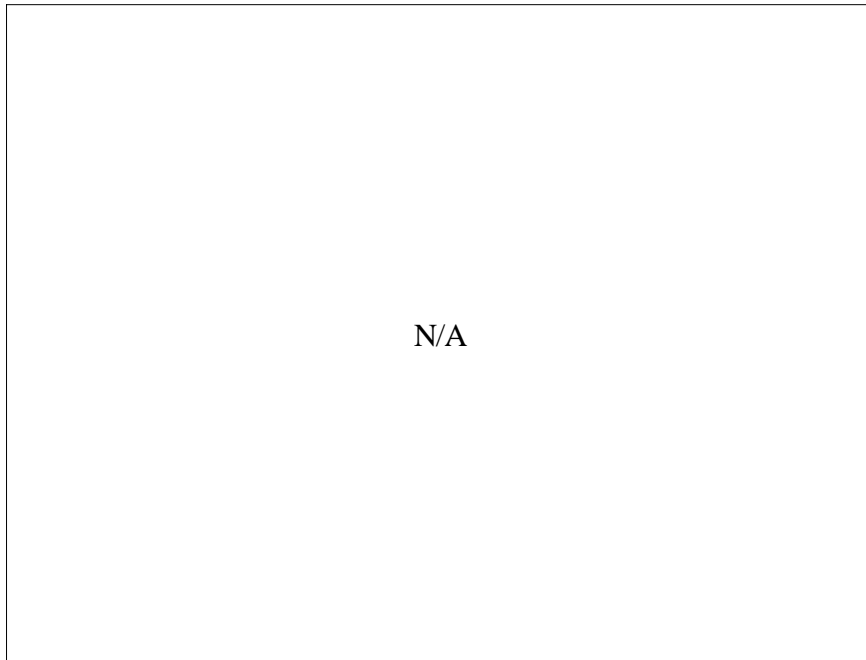

6.2 Radiated Emission

* Below 1 GHz



This report shall not be reproduced except in full, without the written approval of KES Co., Ltd.

The results shown in this test report refer only to the sample(s) tested unless otherwise stated.

* Above 1 GHz

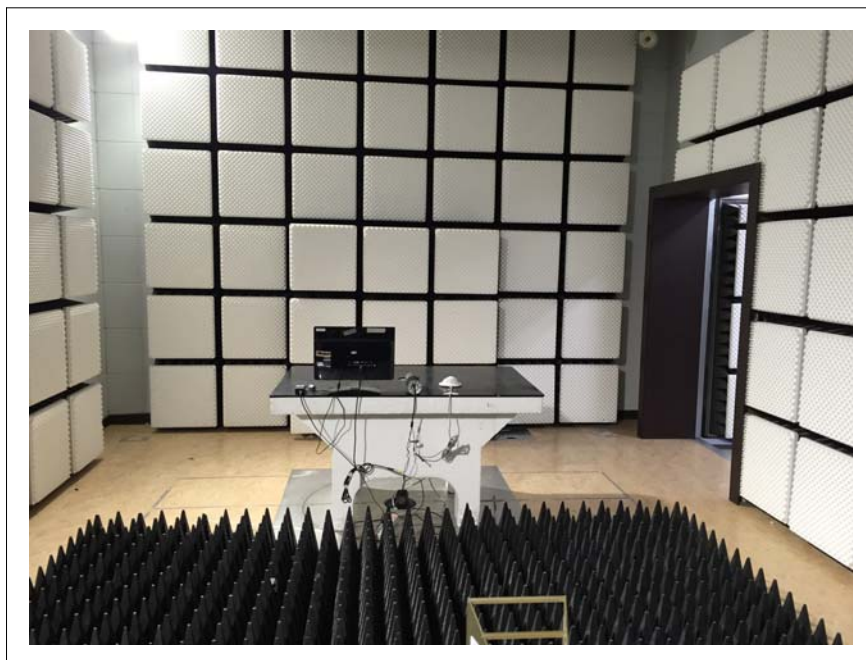
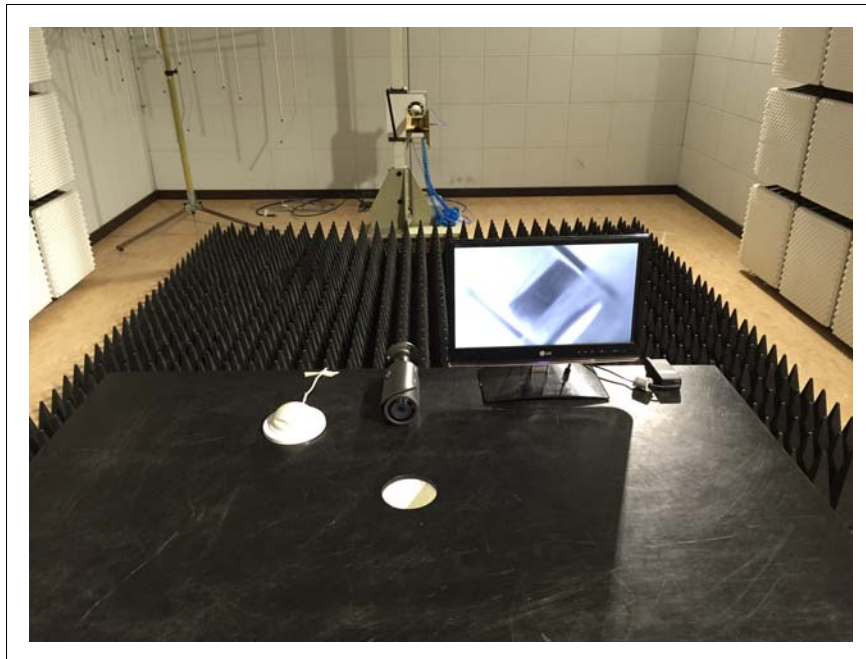

This report shall not be reproduced except in full, without the written approval of KES Co., Ltd.
The results shown in this test report refer only to the sample(s) tested unless otherwise stated.

6.3 Harmonics / Voltage Fluctuations



6.4 Electrostatic Discharge Immunity



This report shall not be reproduced except in full, without the written approval of KES Co., Ltd.

The results shown in this test report refer only to the sample(s) tested unless otherwise stated.

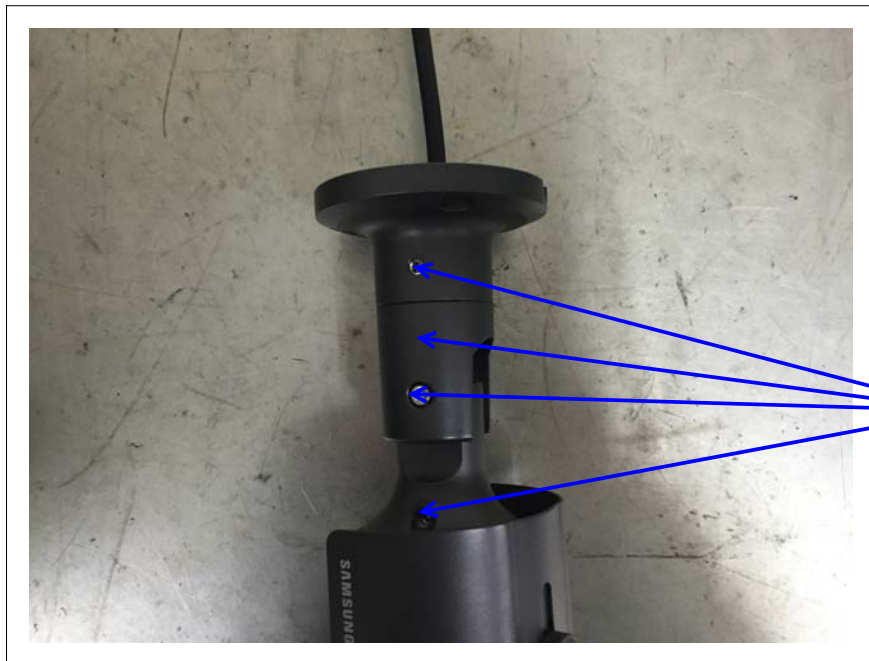

This report shall not be reproduced except in full, without the written approval of KES Co., Ltd.
The results shown in this test report refer only to the sample(s) tested unless otherwise stated.

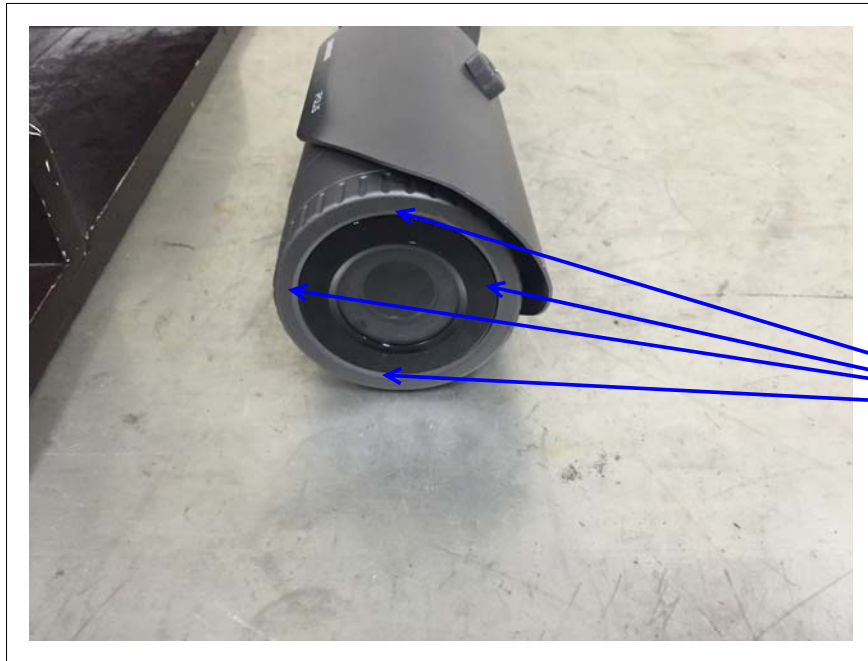

3. Contact Discharge

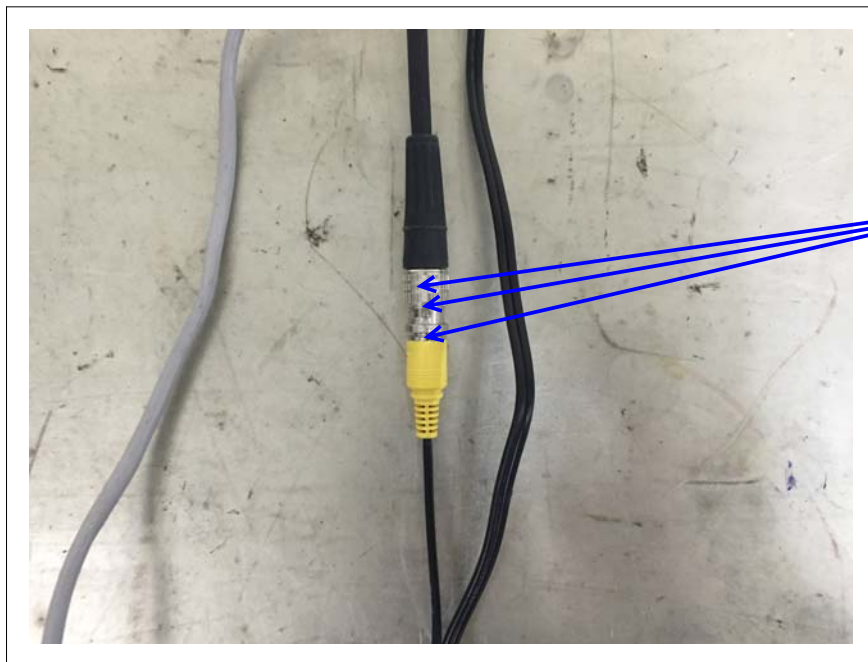

4. Contact Discharge

This report shall not be reproduced except in full, without the written approval of KES Co., Ltd.
The results shown in this test report refer only to the sample(s) tested unless otherwise stated.

6.5 Radio frequency electromagnetic field immunity

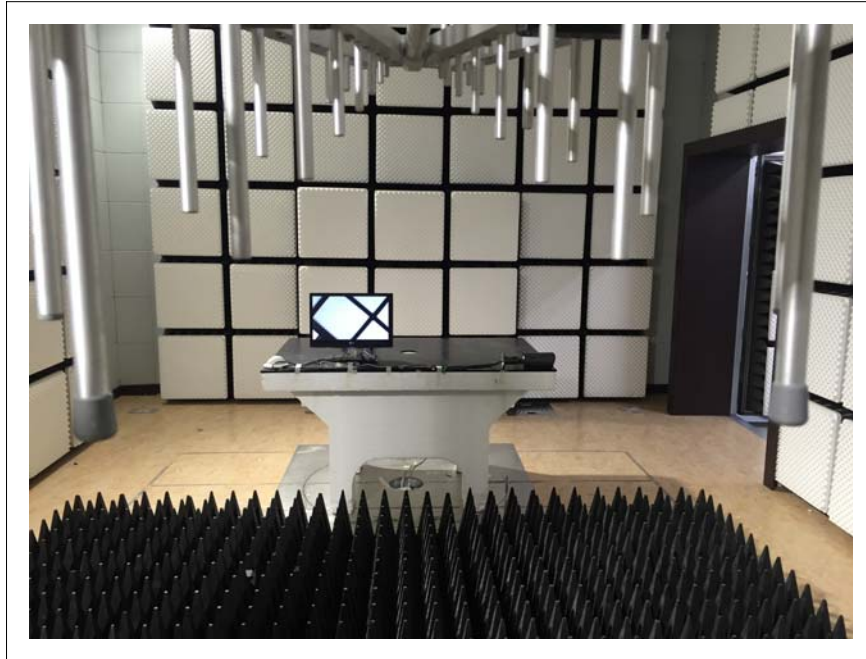

This report shall not be reproduced except in full, without the written approval of KES Co., Ltd.

The results shown in this test report refer only to the sample(s) tested unless otherwise stated.

6.6 Fast Transient Immunity



This report shall not be reproduced except in full, without the written approval of KES Co., Ltd.

The results shown in this test report refer only to the sample(s) tested unless otherwise stated.

6.7 Surge Immunity

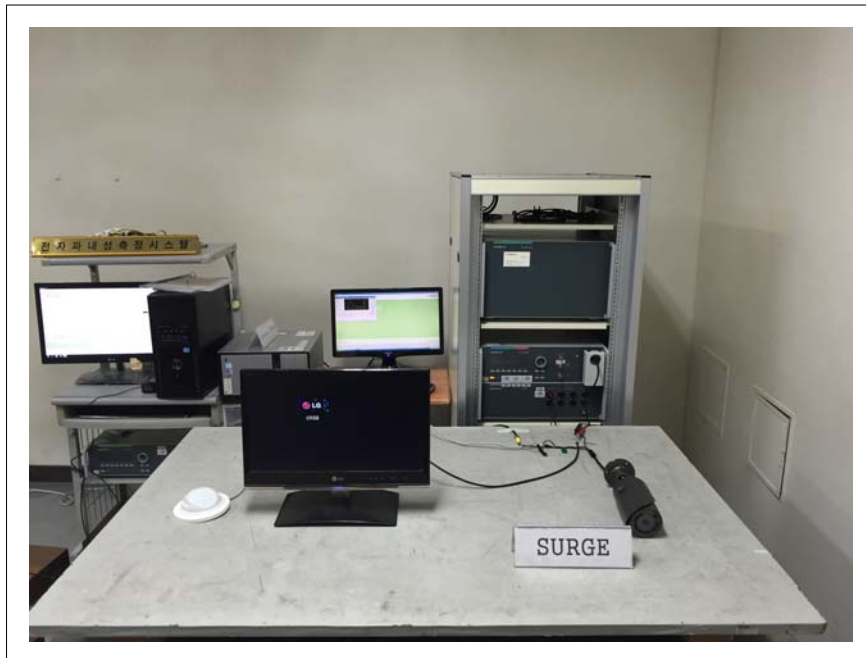

This report shall not be reproduced except in full, without the written approval of KES Co., Ltd.

The results shown in this test report refer only to the sample(s) tested unless otherwise stated.

6.8 Radio-frequency continuous conducted Immunity

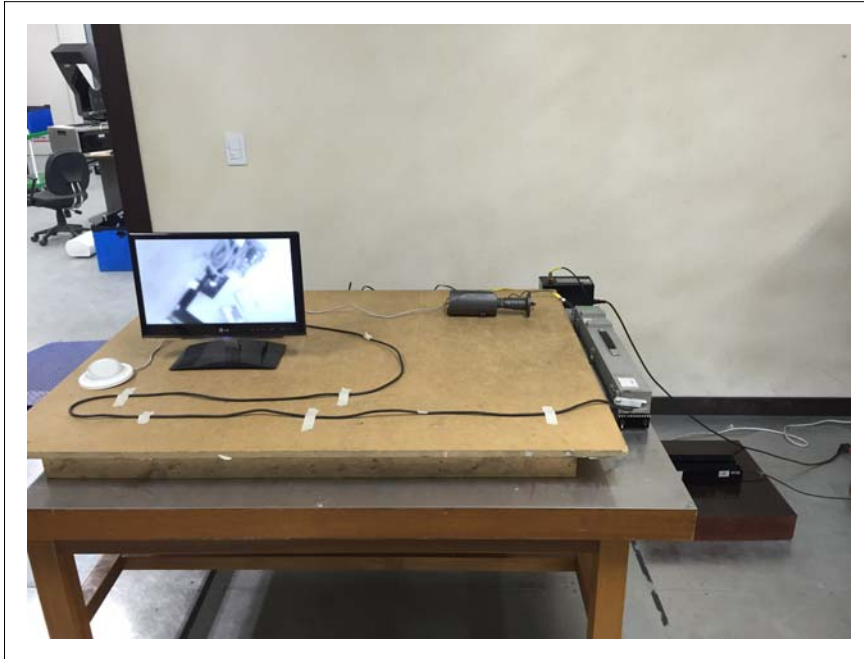

This report shall not be reproduced except in full, without the written approval of KES Co., Ltd.

The results shown in this test report refer only to the sample(s) tested unless otherwise stated.

6.9 Voltage Dips and Voltage Interruptions Immunity



This report shall not be reproduced except in full, without the written approval of KES Co., Ltd.

The results shown in this test report refer only to the sample(s) tested unless otherwise stated.

7. External Photographs



[FRONT VIEW]



[REAR VIEW]

This report shall not be reproduced except in full, without the written approval of KES Co., Ltd.

The results shown in this test report refer only to the sample(s) tested unless otherwise stated.



ANALOG CAMERA

Model No : SCO-6083RP

Manufacturer : Tianjin Samsung Electronics Co.,Ltd.

Made in of China



[LABEL VIEW]

8. Internal Photographs



[INTERNAL VIEW]

This report shall not be reproduced except in full, without the written approval of KES Co., Ltd.

The results shown in this test report refer only to the sample(s) tested unless otherwise stated.

○ IR Board



[TOP VIEW]



[BOTTOM VIEW]

This report shall not be reproduced except in full, without the written approval of KES Co., Ltd.

The results shown in this test report refer only to the sample(s) tested unless otherwise stated.

○ Lens Module

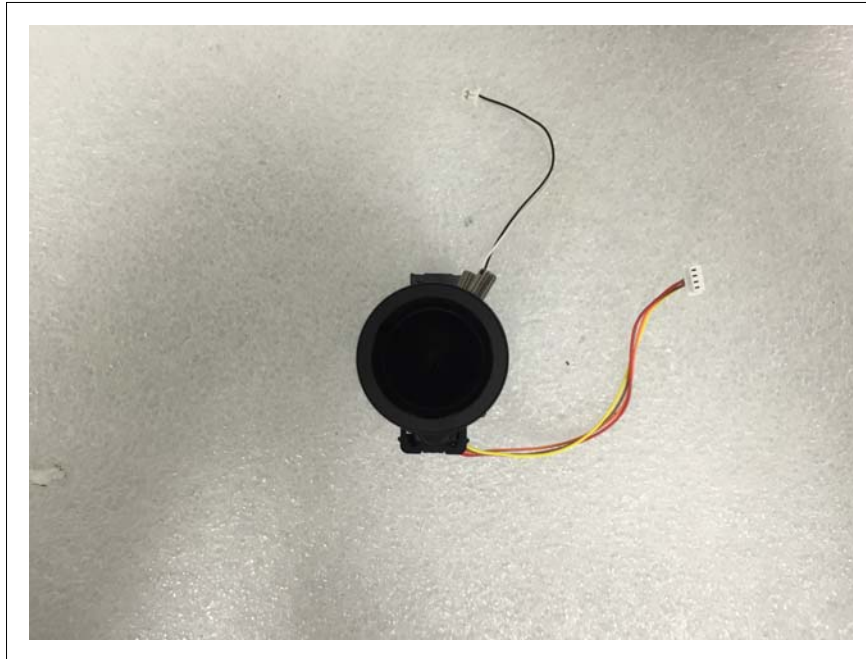

[TOP VIEW]

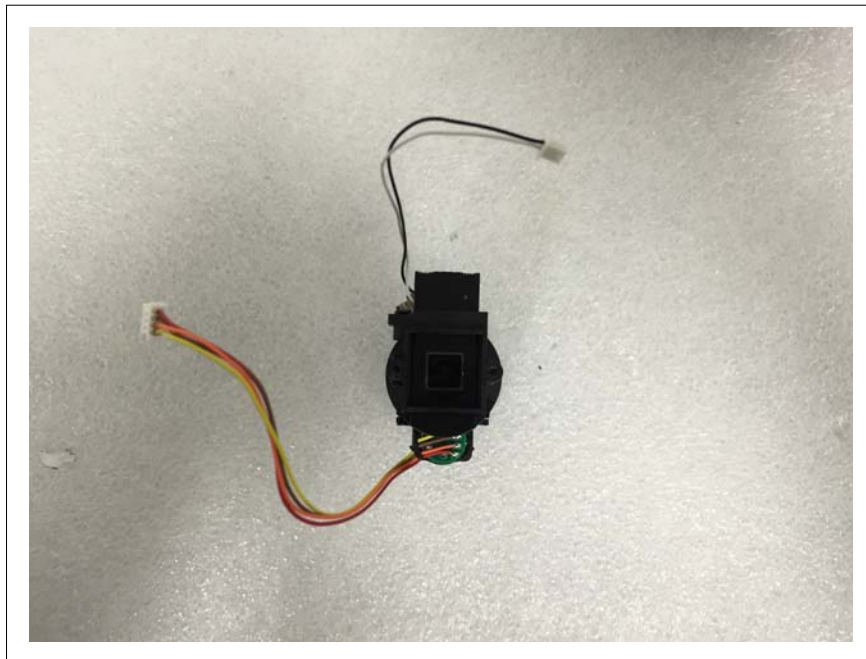

[BOTTOM VIEW]

This report shall not be reproduced except in full, without the written approval of KES Co., Ltd.

The results shown in this test report refer only to the sample(s) tested unless otherwise stated.

○ Main Board



[TOP VIEW]

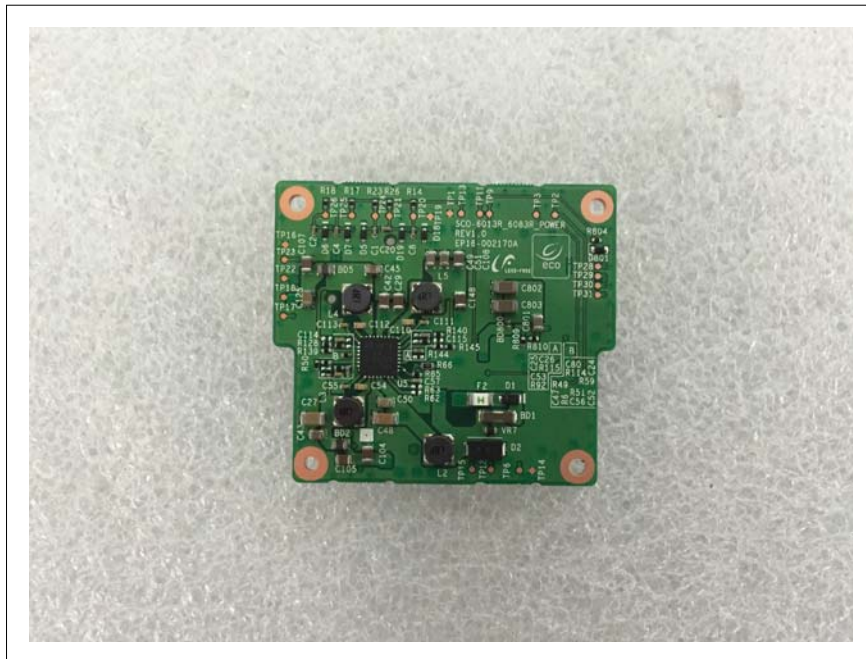

[BOTTOM VIEW]

This report shall not be reproduced except in full, without the written approval of KES Co., Ltd.

The results shown in this test report refer only to the sample(s) tested unless otherwise stated.

○ Button Board

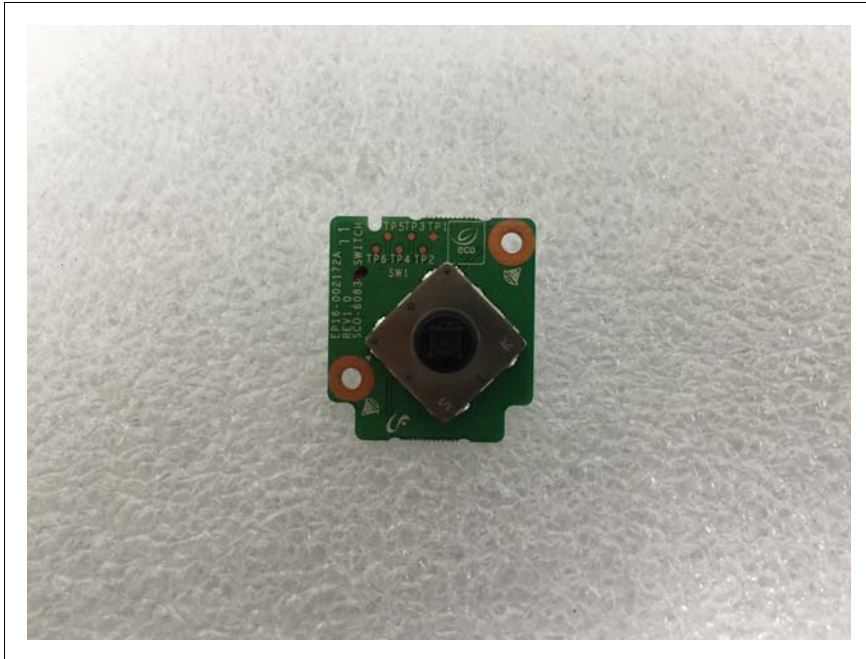

[TOP VIEW]



[BOTTOM VIEW]

This report shall not be reproduced except in full, without the written approval of KES Co., Ltd.

The results shown in this test report refer only to the sample(s) tested unless otherwise stated.

○ Power Board

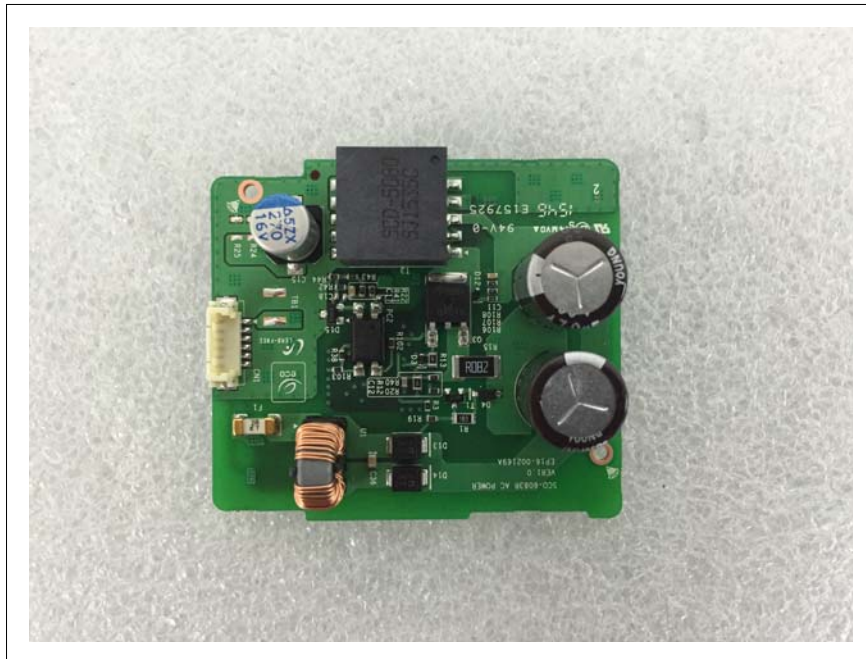

[TOP VIEW]

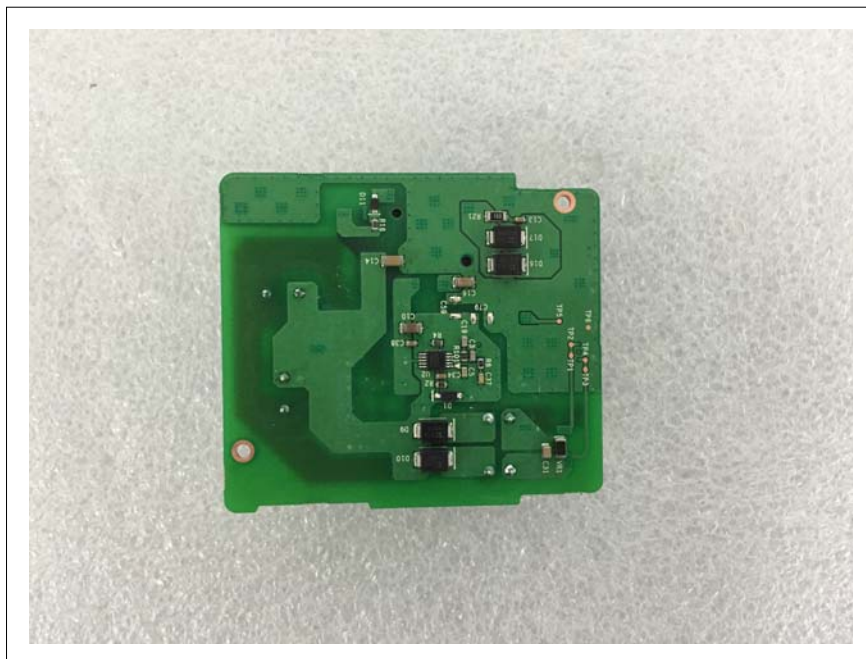

[BOTTOM VIEW]

This report shall not be reproduced except in full, without the written approval of KES Co., Ltd.

The results shown in this test report refer only to the sample(s) tested unless otherwise stated.



Appendix A - Schematics/Block Diagram

Please see attached document(s).



KES Co., Ltd.

C-3701, 40, Simin-daero 365beon-gil,
Dongan-gu, Anyang-si, Gyeonggi-do, 14057, Korea
Tel: +82-31-425-6200 / Fax: +82-31-424-0450
www.kes.co.kr

Test report No.:
KES-E1-15T0342
Page (74) of (74)

Appendix B - User's Manual

Please see attached document(s).

This report shall not be reproduced except in full, without the written approval of KES Co., Ltd.

The results shown in this test report refer only to the sample(s) tested unless otherwise stated.