



# WIRELESS ALARM CONTROL PANEL CB32G

(ver. 1.00, 01.2017)

Installation and operation manual

<b>INTRODUCTION</b> .....	<b>2</b>
<b>KEYPAD USE AND ARMING METHODS</b> .....	<b>4</b>
<b>ARMING &amp; DISARMING OF ALARM SYSTEM.</b>	4
1. <i>Arming &amp; disarming alarm from CB32G panel keypad.</i>	4
2. <i>Operating CB32G control panel using a remote.</i>	5
3. <i>Arming &amp; disarming using a mobile phone.</i>	5
4. <i>Arming the system bypassing selected alarm zones.</i>	5
<b>CB32G SELECTED FUNCTIONS DESCRIPTION</b> .....	<b>5</b>
WIRELESS DETECTOR MONITOR	5
ANTI-SABOTAGE PROTECTION OF EXTERNAL DEVICES	6
OPERATION WITH WIRED ALARM DETECTORS	6
OPERATION WITH REMOTE CONTROL TRANSMITTER (REMOTE)	6
OPERATION WITH EXTERNAL WIRELESS SIREN	6
GSM FEATURES OF CB32G CONTROL PANEL	7
CB32G PANEL CONFIGURATION AND FIRMWARE UPGRADE USING PC	7
<b>MAIN MENU</b> .....	<b>7</b>
ALARM EVENT MEMORY	7
FAILURE CHECK	7
SERVICE SETTINGS (S.S.)	8
1. <i>Event Memory</i>	8
2. <i>Password Change</i>	8
3. <i>Zone Settings</i>	8
4. <i>Outputs settings</i>	10
5. <i>System users - adding, editing and removing a user</i>	10
6. <i>System times settings</i>	12
7. <i>Alarm notification by GSM module</i>	13
8. <i>Auxiliary functions settings.</i>	14
9. <i>Signalling modes of system arming.</i>	16
10. <i>System Status</i>	17
<b>SETTINGS RESET</b> .....	<b>17</b>
RESETTING PASSWORD OF USER NUMBER 1.	17
CB32G RESTORE TO FACTORY SETTINGS (DEFAULT SETTINGS).	17
<b>DESIGNING WIRELESS ALARM SYSTEM</b> .....	<b>18</b>
POWERING CB32G CONTROL PANEL	18
ALARM SYSTEM WITH ELMES CB32G CONTROL PANEL	19
<b>SPECIFICATION</b> .....	<b>22</b>
<b>MANUFACTURER'S LIMITED WARRANTY</b> .....	<b>23</b>
<b>FREQUENTLY ASKED QUESTIONS</b> .....	<b>24</b>

---

## INTRODUCTION

Elmes Electronic CB32G is a programmable, wireless alarm control panel with integrated mobile phone module, designed for use in anti-robbery, intrusion detection and access control installations. It operates with any Elmes Electronic made wireless detectors, RP501 transmitter-receiver set, remote control transmitters and two wired detectors. Its three 1A current rated fused alarm signalling outputs are designed for connecting external signalling devices such as sirens, bells strobes and automatic alarm notification devices. The panel features a real-time clock, non-editable memory log of last 256 events and may be programmed to be remotely armed and disarmed by SMS and CLIP as well as send SMS alarm, status, failure and event notifications. Backlit LCD panel displays appropriate status information while numeric keypad allows convenient programming of the control panel. In the event of AC power failure, dedicated software procedures initiate low energy consumption mode allowing over 24-hour panel autonomy operation with two internal 600-850mAh Li-ION rechargeable batteries (type 14500 – AA size). The panel supports up to 16 system users and enables monitoring of up to 32 wireless and two parametric wired detectors identified as alarm zones. Each user and alarm zone can have any user defined 16 characters name.

The CB32G control panel may be connected to any wired alarm system to support wireless detectors operation. It may be powered from the power supply line of the wired system, and its three signalling outputs can be connected to alarm detection terminals of wired control panel.

***WARNING!*** *This wireless control panel has been designed to be as effective as possible. However, there are circumstances that alarm system may fail to operate as expected for variety of reasons. Users and installers are warned that radio signals from wireless detectors and sensors may not reach the CB32G panel under all circumstances. Metal objects placed on radio transmission paths, deliberate jamming or other radio signal interference can seriously reduce operating range.*

### **General features of CB32G control panel:**

- microprocessor architecture, alphanumeric backlit LCD display and real-time clock,
- integrated mobile phone GSM module for arming, disarming and event notification,
- 32 wireless and two wired parametric alarm zones with user defined names,
- identification of 16 users including 4 administrators with defining their names,
- arming and disarming of the panel by keypad password (3 to 6 digits), by the use of remote control transmitter, or by SMS and CLIP(\*).
- range of alarm zone types for specialized operating purposes,
- functional modes of partial arming of the control panel (day, night modes),
- panic and robbery alarm function (or call for help) activated by remote control,
- memory of the last 256 events, such as arming, disarming, alarms and power failures,
- acoustic signalling (beeps) of entry in a "chime type" zone,
- entry delay activated either by remote control, entering delayed zone or mobile phone,
- programmable "entry" and "exit" delay times in the range from 0 to 99 seconds,
- operation with Elmes Electronic WSS wireless external siren & strobe,
- wireless detector and external wireless siren presence monitoring,
- three wired alarm outputs rated max. 1A with fused overload protection, programmable timing (0-999s), and user defined signalling mode (e.g. alarm, power failure, sys. arming),
- tamper sabotage protection for external signalling device wired to OUT1,
- radio jamming sabotage protection notification in zone 30,
- parametric (1 kOhm) input for TAMPER sabotage protection of external devices,
- RF signal and interference level monitor in operated radio band,

- 92dB internal acoustic siren built-in under the keypad,
- AC powering by external AC/DC unregulated power pack with 10-15VDC/1200mA output,
- over 24 hours autonomy operation with two 3,7V Li-ION rechargeable batteries 600-850mAh each on AC power supply failure,
- three front panel LED diodes for alarms, arming and GSM operation indication,
- easy panel configuration programming and firmware upgrade with the use of PC.

(\*) CLIP - *Calling Line Identification Presentation*.

## **FIRST USE OF CB32G CONTROL PANEL**

If internal GSM module in the control panel will be used, then an active SIM card will be needed. The card should have SMS memory and address book cleared with voice mail box set off. Used SIM card may have PIN code protection set on or off. If the PIN code is on then it should have the PIN set to **1234**. This can be done using any other mobile phone operating in the same GSM network as the SIM card. **The use of SIM card with other than 1234 PIN code in the CB32G control panel may cause the card to be blocked!**

In addition, two 3,7V Li-ION rechargeable batteries (type 14500, AA size) with minimal capacity of 600 mAh and AC/DC power supply pack with 10...20VDC - 1200mA (1.2A) output should be prepared. The control panel may also be powered using external buffered power supply (ups) which will provide longer autonomy operation of the panel on AC power failure. In that case, the use of internal Li-ION batteries is not required.

The following steps should be followed at first setting on the control panel:

- Remove back side part of cabinet.
- If GSM module is to be used, insert prepared SIM card to card socket, observing that the cut corner of the card is in the left upper corner of the socket. The SIM card may also be inserted anytime providing control panel power supply is set off.
- Connect power pack wires (plain without plug) to the control panel power supply connectors observing marked polarity.
- If needed, insert the Li-ION batteries to the CB32G battery compartments carefully observing polarity marked inside.

**WARNING!** Correct battery polarity must be absolutely observed when inserting Li-ION batteries. Incorrect battery placement will cause panel damage and repair service will be required.

- Plug in AC/DC power pack to mains outlet socket. The control panel will initialize readiness to operate displaying software version and initial time and date.
- Go to menu "Service Settings" (factory password: 0000) of the Main Menu and set up required options to configure designed alarm system.

**NOTE!** The GSM module operation is factory set OFF. To set its operation ON go to option 7.8 of the Service Settings and change the option.

Connecting to GSM network will be indicated by fast flashing blue LED. Slow flashing with 2-3 seconds intervals indicates that the module is logged to the network. In menu "System Users" of "Service Settings" user/s phone number/s can be input and operating mode with control panel defined. Remaining module settings can be made in option 7 and 9 of Service Settings.

**ADVICE!** First operation and initial settings of CB32G control panel should be made on any workshop place prior to its firm installation. Final place of the panel installation should be carefully selected to allow its central positioning with regard to installed wireless detectors and to allow optimal GSM network reception. Wireless detector's operating range can be checked in section 3.5 while GSM network reception in section 10.1 of Service Settings menu.

---

## KEYPAD USE AND ARMING METHODS

---

Daily handling of the alarm system with the CB32G control panel involves arming and disarming of the system and checking possibly indicated alarm states. The control panel is operated with the use of keypad buttons described below:

1,3,5,7,8,9,0	-- numeric only buttons,
2▲, ◀4, 6▶, 8▼	-- numeric and menu selection cursor buttons,
C	-- cancel and menu exit button,
OK	-- selection acceptance & confirmation button.

Current status of the system – date/time, arming mode of the control panel are displayed on the LCD while failure, alarm and arming information are indicated by two LEDs:

**"ALARM"** – lights on (red) at alarm detection and flashes indicating system failure. Alarm signalling is cancelled after entering the main menu or re-arming the system. Failure signalling is cancelled after eliminating its cause.

**"ARMED"** – lights on (green) when the system is armed, flashes when exit delay time is counted down.

The causes of alarms or system failures can be viewed upon entering main menu by holding down OK button and next selecting Alarm Memory or Failure Check submenu.

### ARMING & DISARMING OF ALARM SYSTEM.

Arming and disarming of alarm system with CB32G panel may be done from the control panel keypad, by remote control transmitter (later referred to as a "remote"), by mobile phone SMS or CLIP. Disarming alarm stops alarming and silences alarm sirens.

#### 1. Arming & disarming alarm from CB32G panel keypad.

There are two possible methods of arming and disarming using the keypad depending on the system "day/night" operation mode selection, see Service Settings (S.S. for short) 8.7:

1. By entering user's password followed by OK the system will arm if in disarmed state or disarm if in armed state (day/night mode is not selected "N" - see 8.7).
2. By entering user's password followed by OK the system allows a choice of one of four supervision modes selected with "1", "2", "3", "4" keypad buttons (day/night mode is selected "Y" – see 8.7.), as described further:

**"1 - disarm"** - disarming the alarm – "disarmed" status appears on display. "active 24h" anti-tamper zones remain armed.

**"2 - arm"** - arming the alarm. On end of the exit delay (signalled acoustically and optically with displayed time countdown on the LCD panel), all alarm zones are armed (\*). "Armed" status appears on display.

**"3 - day"** - partial arming of the alarm in day supervision mode. The zones earlier defined as "day armed" and the "active 24h" zones are armed (as in 3.1). The "day mode" message appears on display.

**"4 - night"** - partial arming the alarm in the night supervision mode. At the end of exit delay (signalled acoustically and optically) all alarm zones are armed (\*), except for earlier defined as „night disabled" (as in 3.1.). The "night armed" message appears on display.

(\*) Permanently disabled zones are not armed in any of the above modes!

## 2. Operating CB32G control panel using a remote.

The CB32G control panel can be remotely operated by the use of Elmes Electronic made remote control transmitters (e.g. one channel UMB100HT, two channels DWB100HT or four channels CH4HT) in two ways, as described below:

### 2.1 Arming and disarming the system.

One channel remote, e.g. UMB100HT. By pressing control button of single channel transmitter learned to CB32G panel would produce a single loud beep (\*) and starts exit delay time. On end of the exit delay the alarm system is armed. Next pressing of the same control button would produce two loud beeps (\*) and the system will disarm. If alarm occurred while in the system armed state, five loud beeps (\*) would be produced on system disarming.

Two channels remote, e.g. DW100HT. Operation mode of the remote depends on settings made at S.S. 5.7.

Four channels remote, e.g. CH4HT. Button 1 (green) disarms alarm system, button 2 (red) arms, button 3 (blue) arms in night mode, button 4 (grey) arms in day mode.

### 2.2 Remote activates entry delay only.

This mode is possible if „Remote sets on delay” function is selected in S.S. 8.1. Pressing remote button activates entry delay signalled by two loud beeps (\*) and “remote delayed” zone type is disabled for as long as the entry delay time is set. While in entry delay, disarming of the system should be done by entering valid password from the keypad. Failure to disarm control panel and violation of “remote delayed” zone during entry delay will set up intruder alarm at the end of delay.

(\*) Loud signal beeps can also be produced by an external siren wired to OUT1 (see 9.4), then beeps from internal siren are at lower volume, or by wireless Elmes Electronic WSS siren ( see S.S. 9.5).

## 3. Arming & disarming using a mobile phone.

The GSM32G control panel may be remotely armed and disarmed by SMS command or CLIP call from any entitled mobile phone number listed in the panel memory.

## 4. Arming the system bypassing selected alarm zones.

If, in the course of arming the system from control panel keypad, remote or mobile phone SMS or CLIP, one of the zones detects intrusion, the response of the system depends on whether the zone was earlier defined as “bypass” type (see item 3.1.g) and will be as follows:

- if the zone is defined as “bypass” type (Y) – the system generates 3 beeps and, if arming using keypad or remote transmitter only, prompts whether to arm the system without arming the intruded zone. Acceptance with the use panel OK button or remote button arms the system bypassing that zone. The use of any other button or no response (>8s) cancels arming procedure. Arming using mobile phone will arm the system and in return SMS will be received informing of the bypassed zone.
- if the zone is not defined as “bypass” type (N) – the control panel produces 3 beeps and displays message “Violated zones” with zone name and system will not arm. In that case, the cause of the zone violation should be cleared off and a new arming should be made. While arming by mobile phone, the system will respond by sending SMS with information on violated zones.

See also S.S. 9 – “System arming signalling modes”

---

## CB32G SELECTED FUNCTIONS DESCRIPTION

---

### Wireless detector monitor

Elmes Electronic CB32G control panel allows testing the operation of all wireless detectors installed in alarm zones by simultaneous display of their on/off status. To activate/deactivate this function button “1” on the keypad must be pressed and hold down until two 16 points lines

scale appear/disappear on the LCD panel. The displayed points represent all 32 wireless detectors that can operate with the CB32G control panel. Any detector activated in the system produces “\*” mark to be momentarily displayed on the LCD at point position corresponding to alarm zone number to which the detector was learned. Tamper switch activation in the detector produces mark “S” to be displayed in the corresponding zone point on the scale.

### **Anti-sabotage protection of external devices**

Connecting TAMPER switches of external devices (e.g. outdoor siren) as shown on the diagram of Fig.2 enables anti-sabotage protection of these devices. Cutting off or shorting of the tamper wire generates sabotage alarm in zone 32 of the control panel. If the TAMP terminal is not used, it must be shorted to the GND terminal with 1kOhm resistor (supplied). The TAMP input terminal may be used to connect any parametric wired alarm detector to the CB32G control panel.

### **Operation with wired alarm detectors**

Two parametric zones of the CB32G control panel allow connection of any wired alarm detectors with NC (normally closed) output terminals. Input EXT of the panel connects wired detector to alarm zone 31 while input TAMP may be used to connect wired detector to alarm zone 32. Detectors' outputs wiring should be parametric configured using resistors (supplied) with one end wired to the GND terminal, as shown on fig. 1 of the manual. Wired detectors are recognized by the panel the same way as wireless detectors. Alarms are detected in the zone type selected by installer while sabotage protection is supervised as 24h type zone, permanently armed. Parametric resistors should be terminal connected inside wired detector's housing. Wired detectors must be powered by external AC/DC power pack. To ensure detector's proper operation at AC power failure, power pack with integral battery backup should be used (buffered power pack).

**IMPORTANT:** Zones 31 and 32 of CB32G panel are factory set “disabled”. When wired detectors are installed, the zones should be enabled – see S.S. 3.4.

### **Operation with remote control transmitter (remote)**

The use of Elmes made remote to operate with Elmes CB32G control panel allows remote arming/disarming of alarm system as well as enables entry delay time for disarming from panel's keypad. Also, panic alarm may be triggered using a remote. Detailed description of remote functions can be found in pt. 2 of Arming & Disarming of Alarm System section. Learning a remote to CB32G panel is made according to S.S. 5.3. In addition, in “Auxiliary functions settings” menu pt. 8.1, a selection must be made as to whether the remote arms/disarms the system or sets on entry delay only. Also, in 8.8 – a selection whether panic alarm is required or not and in 9.4 and 9.5 whether the use of a remote should be signalled on external siren.

### **Operation with external wireless siren**

The Elmes CB32G wireless panel can operate with dedicated external wireless sound and strobe siren Elmes WSS that features integral transceiver module allowing periodical siren presence test. The siren is powered by external mains power pack (delivered with the siren) that recharges internal, not serviceable, sealed battery being siren's main source of power supply. The following steps are required to set Elmes WSS wireless siren operates with the CB32G control panel:

1. Learn the siren to alarm zone line 29 of the CB32G panel by selecting detector learning mode (see 3.3) and activating the siren to transmit alarm signals in one of the three ways, as below:
  - a. Connecting siren's battery while mains power supply is off.
  - b. Connecting or disconnecting mains power while battery is connected.
  - c. Activating siren's housing top cover sabotage switch.

2. Set required alarming time at OUT1 of the panel that equals to alarming time of the wireless siren (6.4).
3. Set required time interval (1 to 99 minutes – 20 minutes as standard) between which wireless siren presence is tested (as described in S.S. 6.5) and enable radio link testing (8.3).
4. Choose the way alarm system signals that radio link between wireless siren and the control panel is in fault. If the system is expected to set on loud alarm along with failure indication by LED, the function in pt. 8.11 should be set to ON. If only failure indication by LED is required then the function should be OFF.
5. If control panel is armed/disarmed from a remote (8.1), its use signalled by external siren can be set off (see 9.4 and 9.5).

**NOTICE!** To avoid loud TAMPER alarm during maintenance service or installation when siren's housing is to be opened, temporarily disable alarm zone line 29.

### **GSM features of CB32G control panel**

The following features are available when using CB32G panel : remote arming and disarming of alarm system by SMS or CLIP call, alarm system status notification, remote disabling of alarm zones, SMS notifications to up to 8 mobile phones on alarms, arming/disarming, AC supply failure and return as well as system failures. Notifications include information of the source of the event. In case of intruder alarm and sabotage alarm, control panel makes also a CLIP call to registered phone numbers. It may also operate with any GSM mobile monitoring system by responding to its test signals and sending cyclic SMS notes or making CLIP calls.

### **CB32G panel configuration and firmware upgrade using PC**

The CB32G control panel can be easily configured and firmware upgraded with the use of Windows® based PC (Personal Computer). To connect the panel to PC a dedicated USB-RS interface cable is needed (ordered separately). Also, installation of virtual COM port drivers at the PC are necessary. The drivers as well as dedicated "CB32G Configurator" configuration software are free for download from the panel manufacturer web site: [www.elmes.pl](http://www.elmes.pl) .

Before any data is send to or received from the CB32G panel, the following installation steps should be followed:

1. Select serial COM port that appears new in "CB32G Configurator" options after connecting the USB-RS interface cable to PC.
2. By holding down button "2" of the panel's keypad at power on, force the panel to set up communication mode with PC. Displayed flashing "?" sign on panel's LCD confirms the mode has been entered.

---

## **MAIN MENU**

To access the main menu of the CB32G panel press and hold down OK button for more than two seconds. Navigate the menu using vertical and horizontal cursor keys. If the keypad is not used for more than two minutes the menu exits and display of the current status of the control panel on the LCD panel returns.

### **Alarm Event Memory**

In this menu details of the latest alarm events are displayed: date, time and zone of the alarm(s) source. The use of ▲▼ keys selects earlier or later events respectively, while the use of ◀▶ buttons selects between alarm type and alarm source, e.g. "Intruder alarm" ↔ "kitchen".

### **Failure Check**

This menu is designed to view the causes of the failures signalled on the control panel by flashing "ALARM" LED. Failures signalled on the control panel include:

- Mains power supply failure.
- Rechargeable battery absence or failure.
- Communication errors with wireless detectors or siren.
- Detector's low battery.
- Communication error with GSM module.

▲▼ keys are used to scroll through failures.

The "ALARM" LED stops flashing when the cause of failure is cleared.

## Service Settings (S.S.)

Access to Service Settings menu is enabled only if the control panel is disarmed and upon entering a valid password code confirmed by OK button. Factory setting of the password for the user No.1 is „0000“. Exit from the menu and cancelling entries are made by the C button. Users Nos. 1-4 (administrators) have access to all functions whereas other users may access functions 1-2 only. All editable service settings available in this menu are described further.

### 1. Event Memory

Service settings → Event memory

This menu allows viewing detailed information on last 256 events that occurred in the system (alarms, failures, arming, disarming, errors, etc.). Event memory cannot be edited, and allows only viewing the event details in the sequence of their occurring date and time. Buttons ▲▼ select an earlier or later event while ◀▶ buttons select between type of event and its source, e.g. "Arming" ↔ "John".

### 2. Password Change

Service settings → Password change

This menu allows changing user's own password. Password of other users can be changed in the "Users" menu (see pt. 5). After accessing this menu "Enter password" prompt appears. Enter new password containing 3 to 6 digits, and then press OK. When the "Repeat password" prompt appears, enter the new password again and press OK. The new password replaces old one. In case of entering an existing or incorrect password "Wrong password" message appears.

### 3. Zone Settings

This menu contains several submenus. Entering any submenu with ▲▼ buttons selects zones while ◀▶ buttons select between zone number or zone name, e.g. "Zone no 1" ↔ "Kitchen".

#### 3.1. Assigning functions to alarm zones.

Service Settings → Zone settings → Zone function

In this menu Elmes CB32G control panel allows assigning functions to alarm zones. Buttons ▲▼ select one of the functions described below while ◀▶ buttons allow setting the function ON (Y) or OFF (N). The use of OK button accepts the selection while the use of C button cancels changes and exits the menu without saving changes.

- |                     |  |
|---------------------|--|
| a) "24h"            | - 24 hour zone, e.g. anti-sabotage zone (permanently armed),   |
| b) "day armed"      | - zone armed in day supervision mode selection,                |
| c) "night disabled" | - zone disabled in night supervision mode,                     |
| d) "remote delayed" | - zone with entry delay set on by remote control transmitter,  |
| e) "delayed"        | - standard entry zone with delayed alarming,                   |
| f) "chime"          | - zone with door chime beep feature on zone violation,         |
| g) "bypass"         | - zone that can be left disarmed if violated on system arming. |

A standard zone has functions a)..c) set off in armed state mode, when the system is "armed" or in "night armed" mode and disarmed when the system is "disarmed" or in "day armed"



mode. **IMPORTANT:** Zones can have assigned more than one function, but some functions exclude others. In that case, only one selection is valid, e.g.:

- if a zone is “active 24h” then functions such as “day armed”, “night delayed”, “delayed”, and “bypass” have no meaning;
- if a zone is delayed, it should not be disabled by remote.

#### Examples of assigning functions to alarm zones:

- Entry zone can be “remote delayed”, i.e. after using remote button entry delay countdown is started. Security violation in the zone during the countdown will not generate the alarm immediately, but after the countdown is finished. That allows user sufficient time for safe disarming the system.
- Entry zone can also be a delayed zone, i.e. when the zone is violated, the entry delay countdown starts and the system must be disarmed before the countdown is finished. If system is not disarmed an audible alarming sets on.
- The “chime type” zone which often is also a “delayed” or “remote delayed” zone, generates two beeps sound signal on every violation of the zone (e.g. notifying customer entrance to a store).
- A basement zone can be “day armed” but it cannot be “active 24h” simultaneously.
- A „bypass” zone type allows arming the alarm while intentionally leaving a window opened protected by CTX3H or CTX4H detector (see “System Arming”).

#### 3.2. Zone name.

Service settings → Zone settings → Zone name

This menu allows alarm zones used in the system to have user defined up to 16-character name, e.g.: kitchen, living room, office, Mark’s Room, etc. Uppercase and lowercase letters, digits and the following characters are accepted: space, “-,./”.

Buttons ◀▶ select the successive letters of the name while the ▲▼ buttons browse character table. Accept name with OK button. Use C button to exit the menu.

#### 3.3. Learning wireless detectors.

Service settings → Zone settings → Learning detectors

In this menu use the ▲▼ buttons to select zone number, and the ◀▶ buttons to toggle between displaying the zone number and zone name, e.g.: zone 1 ↔ kitchen. OK button accepts all selections. If detector is already learned to selected zone, “OK-remove” prompt appears. Pressing OK button deletes detector in the zone. If zone is vacant, the “OK-learn” will appear on the LCD. Pressing OK button starts learning detector to the zone. In response to the “Awaiting trans. 1” and “Awaiting trans. 2” prompts, two successive alarm transmissions must be triggered from detector (\*). Correct learning will be followed by “OK-correct” message. Errors are signalled by 3 beeps and “Program error” message. The use of C button exits the menu.

(\*) For detailed information on how to learn any Elmes detector to Elmes CB32G control panel please refer to instruction manual of the detector.

#### 3.4. Zone disabling.

Service settings → Zone settings → Zone disabling

Buttons ◀▶ disable and enable zone selected with ▲▼ buttons. Accept selection with OK button. Exit the menu with C button.

#### 3.5. Radio range test.

Service settings → Zone settings → RF range test

To assess the level of radio reception of signals received from detectors, the most distant detectors in particular, the CB32G panel is provided with “RF range test” function allowing the received signal level to be displayed on 16-point bar graph scale of LCD.

After entering this menu all RF signals in the 433.92MHz radio band will be displayed in form of bar graph. The detectors should be triggered to send alarm transmissions. The longer the distance of the detector from the control panel, or the greater difficulty in radio waves propagation, the lower the level of received signals and the length of the displayed bar graph. If the number of displayed fields is lower than three it should be assumed that this connection does not guarantee reliable alarming. The location of detectors or the control panel should be changed in search for better connection quality. The “RF range test” function allows also assessing levels of all local RF signals in the 433.92MHz band, also those that can interfere and disturb operation of the wireless alarm system. The test should be carried out prior to permanent installation of alarm devices or, in search for causes of short operation range. To find out any interfering signals, the LCD bar graph 16-point scale readouts should be observed without activation of own detectors. Frequent or continuous unknown RF signals received and signalled on the control panel display indicate close presence of other RF devices operating in the same RF band. If level of these signals exceeds three fields displayed in the “RF range test” function and their occurrence is frequent, acceptable signals from detectors may not be received and the alarm system may fail to operate properly.

#### 4. Outputs settings

Service Settings → Outputs settings

In this menu intended use of wired outputs of the control panel can be defined. All three outputs of the panel are OC type and connect to ground in active state. Output OUT1 is designed exclusively for connecting external signalling device and can be sabotage protected (see S.S. pt. 8.4). In addition, this output can be configured to signal the use of a remote. The use of wired outputs OUT 2-3 could have the following designation:

- “**alarming**” - for connection of outdoor/external alarm signalling devices, e.g. external siren or/and strobe. Alarming time can be set within 0-999 seconds range separately for each output (see 6.4);
- “**AC power failure**” - signalling AC power supply failure/cut off;
- “**arming**” - signalling on system armed or night armed and inactive on system disarmed or in day armed mode;
- “**failure**” - signalling any failure state in system (also AC power failure).

**Example:** if “**arm/disarm**” signalling mode is selected at OUT 2 and the output is connected to powered external LED, lamp, etc., it will switch on the device for as long as system is armed warning of the security system being in supervision state. The “**arm/disarm**” mode can also be used for remote control. For example, operated with Elmes ST100HGR controller it may control opening/closing of window rollers.

Signalling mode at OUT 2-3 are set by accessing the menu, selecting output number with ▲▼ buttons, accepting with OK, then selecting signalling type with ▲▼ or ◀▶ buttons and accepting with OK button.

#### 5. System users - adding, editing and removing a user

Service Settings → System Users

This menu contains several submenus. Entering any submenu with ▲▼ buttons selects system user number while ◀▶ buttons select between user number or user name, e.g. “User no 1” ↔ “John Dutch”. Accept user selection with OK button and pass on to submenu:

##### 5.1 Setting and edition of user password.

Service Settings → System Users → Password

Please follow detailed instructions in “Password Change” menu (S.S.1).

To delete user's password press OK button when "Enter password" prompt appears. On next prompt "OK-delete password" again press OK button. "Password deleted" message confirms password is deleted.

### 5.2 User name change.

Service Settings → System Users → Name

Please follow detailed instructions as in "Zone name" menu (S.S. 3.2)

### 5.3 Remote learning and deleting.

Service Settings → System Users → Learning a remote

In this menu user's remote is learned or deleted. Please follow detailed instructions in "Learning detectors" menu (S.S. 3.3).

### 5.4 Disabling of user.

Service Settings → System Users → Disabling user

Please follow detailed instructions as in "Zone disabling" menu (S.S. 3.4). After disabling a user, its remote and password are inactive. In order to disable user's control of CB32G panel by SMS or CLIP, the functions should be set off in 5.6.9 and 5.6.10 of S.S.

### 5.5 Mobile phone number.

Service Settings → System Users → Phone number

This menu allows entering user's mobile phone number. The number must be preceded by national dialling code number, without the "+" sign. Example: 33xxxxxxxx for France.

### 5.6 Mobile phone functions.

Service Settings → System Users → Phone functions

This menu allows selection (Y/N) of notifications, messages, commends and SMS/CLIP functions required active in user's GSM phone operating with CB32G control panel.

- 1) SMS on alarm - sending SMS on alarm set on;
- 2) SMS on arming - sending SMS on arming and disarming of system;
- 3) SMS on powering - sending SMS on mains power failure and return;
- 4) SMS on radio link off - sending SMS on radio link failure;
- 5) SMS on low battery - sending SMS on low battery;
- 6) SMS on other failures - sending SMS on other failures (e.g. accumulator failure);
- 7) Alarm CLIP - making alarm CLIP call;
- 8) Descriptive SMS <-> SMS with ID codes - selection of SMS content: event description such as "Intruder Alarm" or two character ID codes defined in 7.9.
- 9) SMS accept - SMS commands (as below) acceptance received by CB32G.  
ARM, DISARM, NIGHT and DAY- sets appropriate arming mode;  
DISABLE zone\_name - disables zone: zone\_name;  
ENABLE zone\_name - enable zone: zone\_name;  
STATUS - in response control panel sends SMS on current armed/disarmed status and failure events;  
TIME HH:MM - sets time in control panel;  
TEST - sets up instant test procedure and starts time count to next test under condition that "Test every time interval" is selected in 7.10.2 and "Execute test" function is selected in 5.6.12.
- 10) CLIP arming - remotely CB32G panel arming and disarming by CLIP call. Panel is disarmed if call is rejected after one ring. If the call is rejected after three rings, the panel is armed.
- 11) Call back - calling back function. If the control panel is called, it will call back. This and next function may be used in operation with monitoring center:

- if the function is set on, GSM monitoring center calls to CB32G and the panel rejects the call after 3-4 seconds,
- if the function is set off, the control panel calls back the monitoring center after rejecting incoming call.

12) **Execute test** - executing SMS or CLIP time interval test by CB32G panel. The function may be used in operation with monitoring center. See also 7.6, 7.7, 7.10 of system users section.

### 5.7 Remote type and mode of operation.

**Service Settings** → **System Users** → **Remote type**

This menu allows selection of remote's operation modes. Description: 1CH-one channel remote, 2CH-two channels remote, 4CH-four channels remote.

**1CH: arm/disarm** - any selected button alternatively arms and disarms control panel. Remaining buttons, of e.g. 4-channels remote, may be used for other remote control purposes.

**2CH: arm/disarm, night/disarm** - button 1 (green) of 2-channels remote (\*) arms and disarms control panel alternatively while button 2 (red) arms in night mode and disarms the panel.

**2CH: disarm, arm** - button 1 (green) of 2-channels remote (\*) disarms while button 2 (red) night arms the panel.

This mode allows real time clock channel of Elmes STX remote to arm/disarm control panel automatically, at predefined times.

**2CH: disarm, night arm** - button 1 (green) of 2-channels remote disarms while button 2 (red) arms in night mode.

**4CH: disarm, arm, night, day arm** - button 1 (green) disarms system, button 2 (red) arms, button 3 (blue) night arms, button 4 (grey) day arms.

(\*) In this mode a 4-channel remote can also be used. Button 1 is then meant as the first of 1-2 or 3-4 buttons pairs.

**NOTE:** Users 1..4 are system administrators with unlimited access to all service functions, whereas other users have access to Service Settings functions 1 and 2 and are allowed to change their password and review CB32G event memory only.

## **6. System times settings**

### 6.1. System date/time setting.

**Service Settings** → **Times settings** → **System date/time**

This menu allows setting system date and time. The ▲▼ and ◀▶ buttons are used to select current date and time and the use of the OK button accept the selection. Exit the menu with C button.

### 6.2. Entry delay time (0..99s).

**Service Settings** → **Times settings** → **Entry delay**

This menu allows setting the alarm activation delay time (in seconds: 0 to 99) needed to enter the premises and disarm alarm system from the CB32G keypad. Two digits on the right side of the display show available entry delay time in seconds. The required time is set with the use of cursor buttons and accepted with the OK button.

### 6.3. Exit delay time (0..99s)

**Service Settings** → **Times settings** → **Exit delay**

This menu allows setting time delay needed to exit premises (in seconds: 0-99) after alarm system arming from the CB32G keypad. Two digits on the right side of the display show available exit delay time in seconds. The required delay time is set with the use of cursor buttons and is accepted with the OK button.

#### 6.4 Alarm duration timing at outputs 1 to 3 (0..999s).

**Service Settings** → **Times settings** → **Alarm duration OUTx** where x=1, 2 or 3.

This menu allows setting alarm duration timing (in seconds: 0 to 999) on outputs OUT1..3 individually. Three digits on the right side of the display specify current alarm duration in seconds of selected output. The required time is set with the use of cursor buttons and is accepted with the OK button. Alarm duration of OUT1, the built-in siren and wireless Elmes WSS siren are the same. Timing set for outputs function other than alarming has no meaning for their operation.

#### 6.5 Wireless siren check up interval (1..99 minutes).

**Service Settings** → **Times settings** → **WSS siren check-up interval**

This menu allows setting time interval between checking of Elmes WSS wireless siren presence (in minutes: 1 to 99) - as standard set to 10 minutes. The required interval time is selected by the use of cursor buttons and accepted by OK button.

#### 6.6 Control panel clock run adjustment.

**Service Settings** → **Times settings** → **Clock adjustment**

This menu allows adjustment of control panel clock fast/slow run within -99 to +99 steps range. Decreasing steps slow the clock while increasing steps speed up clock. One adjustment step equals 0,0864 second fast/slow run per day (24h).

### **7. Alarm notification by GSM module**

This menu defines required settings for alarms and other notifications send by GSM module of the CB32G panel.

#### 7.1 SMS center phone number.

**Service Settings** → **GSM monitoring** → **SMS Center number**

This menu is used to enter the phone number of GSM operator's SMS center, preceded by country code dialling without "+" mark in front. This is important if "Use entered SMS center no" selection is made in menu 7.10.6. If option "Use default SMS center no" is selected, this field can be left empty. Example: the following phone number should be entered for Plus GSM operator in Poland: 48601000310

#### 7.2 Alarm & arming SMS notifications daily limit (24h).

**Service Settings** → **GSM monitoring** → **Alarm SMS daily limit**

Feature allowing limitation of daily SMS notifications send by CB32G control panel on system alarm, arming and disarming. Limit is factory set to 99 and resets daily at 12:00 hours.

#### 7.3 System failure SMS notifications daily limit (24h).

**Service Settings** → **GSM monitoring** → **Failure SMS daily limit**

Feature allowing limitation of daily SMS notifications on system failures send by CB32G control panel and registered in event memory. Failures are divided into three categories. First category includes "Mains power failure", "Accumulator failure" and "System restart", second "Radio link failure" and third "Low battery" failure. SMS notification limit is factory set to 10 in each category and resets daily at 12:00 hours. Change of factory limit (10) results in limit change in all categories and CB32G event memory.

#### 7.4 Calling duration.

**Service Settings** → **GSM monitoring** → **Calling duration**

This feature defines duration of CB32G alarm notification CLIP calling. It should be set to time value allowing user to reject call before the time lapse if function "Alarm CLIP once" (S.S. 7.10.5) is set off. See also pt. 5 of FAQ section of manual.

## 7.5 SMS password.

Service Settings → GSM monitoring → SMS password

This menu is used to enter a maximum 6-character password that will precede SMS command text, if option “SMS with password” is selected in 7.10.3.

## 7.6 Test SMS.

Service Settings → GSM monitoring → Test SMS

This menu is used to enter Test SMS content send by GSM module when test function is set on in 5.6.12 and “Test as SMS” option is selected in 7.10.1.

## 7.7 Test interval/Test time.

Service Settings → GSM monitoring → Interval/Test time

This menu is used to enter time interval (if option “Test interval” is selected in 7.10.2) or, test time (if option “Test time” is selected in 7.10.2) when the CB32G control panel is expected to perform SMS or CLIP test. Maximum value is 24h. This feature is valid only if “Execute test” option is selected in 5.6.12.

## 7.8 Switching integral GSM module ON and OFF.

Service Settings → GSM monitoring → Mobile phone type

This menu is used to switch on/off control panel GSM module operation. Enter the menu with OK and select GSM Module ON or OFF operation using ◀▶ buttons.

## 7.9 Definition of SMS notification ID codes.

Service Settings → GSM monitoring → SMS ID codes

This menu is used to enter two character ID codes send in SMS event notifications. Each code contains two characters (ASCII codes in range 32 to 90 decimal), e.g. some symbols, digits and uppercase English alphabet characters. To set the CB32G panel to send ID codes instead of standard text notification, such as “Intruder alarm: kitchen”, option “SMS with ID codes” must be selected in S.S.5.6.8.

## 7.10 Auxiliary GSM notification settings.

Service Settings → GSM monitoring → Aux GSM settings

- 1) Test as CLIP <-> Test as SMS - interval test as CLIP call or SMS;
- 2) Execute test at time <-> Execute test after interval - test executed daily at predefined test time, or test after predefined time interval;
- 3) SMS with password - if Y (yes), SMS send to CB32G must begin with password;
- 4) Letter case sensitive - N (no) as standard. If selected Y (yes), the control panel is SMS letters case sensitive;
- 5) Alarm CLIP once - if this function is set off (N), control panel expects CLIP notification rejection. If the call (see pt. 7.4) is not rejected, the panel disconnects and repeats CLIP call twice. If the function is set on (Y), CLIP calling is made once only, even the call was not rejected. It does not refer to a control CLIP that is made only once;
- 6) Use default SMS center no <-> Use entered SMS center no – selection of the first option allows CB32G panel to use SMS center number supplied with SIM card, while selection of the second option causes CB32G to use center number entered in 7.1.

## **8. Auxiliary functions settings.**

This menu contains auxiliary functions and options for alarm system configuration available in the CB32G control panel. Use ▲▼ to toggle between functions and ◀▶ buttons to change setting. OK button saves selection. Exit menu any time with C button without saving selection.

### 8.1 Arming & disarming alarm system with remote.

Service Settings → Aux functions → Remote arm/disarm / Remote sets on delay

This menu allows user to select remote/s operating mode. Remote may arm, disarm alarm system or set on time delay in zones type “remote delayed”, see 3.1.d.

### 8.2 Radio jamming protection.

Service Settings → Aux functions → Jamming protection

This function allows radio jamming anti-sabotage protection of wireless alarm system. If selected (Y), it will activate sabotage alarm in zone 30 on all deliberate or incidental jamming in used radio band.

### 8.3 Radio link test.

Service Settings → Aux functions → Radio link test

Setting this function to (Y) enables monitoring of the detector presence. Radio link transmissions are sent at cyclic intervals from detectors (except for CTX3H) received by CB32G control panel. If, for any reason, radio link transmission from a detector is not received during 24 hours, “radio link failure” will be indicated by flashing “ALARM” LED in the panel.

### 8.4 Anti-sabotage protection test of output 1.

Service Settings → Aux functions → Out1 Test

OUT1 output, which is by default used for connecting an external signalling device, is provided with anti-sabotage (Tamper) protection against wires cutting off or shorting to ground. After accessing this menu the user can turn this protection on or off. Damage, cutting off or shorting wires connecting this output with external signalling device - is indicated by sabotage alarm in zone 32.

### 8.5 Internal siren alarming.

Service Settings → Aux functions → Internal siren

This option allows setting on/off alarm signalling by control panel internal siren.

### 8.6 Signalling accumulator absence or failure.

Service Settings → Aux functions → Accu failure

This option allows setting on/off CB32G internal accumulator failure signalling, recommended to be set to off (N) when rechargeable batteries are not used.

### 8.7 Activating selection of day & night arming modes.

Service Settings → Aux functions → Day/night mode

Activating the function (Y) will display additional menu on LCD allowing selection of supervision modes confirmed by password and the OK button. There are 4 modes available: 1 - disarmed, 2 - armed, 3 – day, 4 – night (see also: “Arming/disarming alarm system”). With the function set off (N), the menu is not displayed and entire alarm system can be armed and disarmed from control panel keypad by password followed by OK. Partial night mode and day mode arming would not be available to set on from keypad. However, night mode arming is still possible if arming is made by the use of a remote (see details in 5.7).

### 8.8 Panic alarm (call for help) function.

Service Settings → Aux functions → Panic alarm

Setting this function on (Y) allows panic alarm for users equipped with remote control. The alarm is activated when remote button is pressed for longer than 2 seconds and lasts for as long as the alarming time set on the OUT1. Control panel registers the event as panic alarm and user's name. With GSM module on, an appropriate SMS notification is send. Setting the alarm OFF is done by entering a password from keypad or by the use of remote control if “Remote arming/disarming” function (8.1) is set on.

### 8.9 Control panel beeps on/off.

**Service Settings** → **Aux functions** → **Keypad beep**

This option allows setting on/off all control panel beep signals except for signalling an intruder alarm that can be set off in 8.5.

### 8.10 Beeps on entry delay count on/off.

**Service Settings** → **Aux functions** → **Entry delay countdown beep**

This option allows setting on/off entry delay countdown beep signals in addition to countdown display on control panel LCD.

### 8.11 Alarm on radio link with WSS siren failure.

**Service Settings** → **Aux functions** → **WSS siren link alarm**

Setting this function to yes (Y) allows loud alarm along with LED alarm notification on wireless Elmes WSS siren radio link check-up test failure. As standard the function is set to no (N) and the failure is signalled by flashing Alarm LED only. Failure check menu will display "Radio link error" and name of zone 29 (if specified).

### 8.12 Limitation of alarms from one alarm zone.

**Service Settings** → **Aux functions** → **Alarms limit to 3**

This function limits number of alarms in one zone to three and is factory set to on (Y). Alarms count is reset on every arming or disarming of the system. When the limit is selected to off (N) alarm sets on every time violation is detected in the alarm zone.

### 8.13 Selection of menu language: Polish/English.

**Service Settings** → **Aux functions** → **Język polski / English language**

This function allows selection of the panel's menu language: English or Polish.

NOTE! Change of menu language can also be made with button "1" of the keypad held down while connecting power supply to the panel.

### 8.14 Backlight modes of LCD panel and keypad.

**Service Settings** → **Aux functions** → **Permanent backlight**

Setting this function to yes (Y) selects permanent backlight of LCD panel and the keypad. As standard the function is set to no (N), meaning the LCD panel and the keypad are backlit upon any key on the keypad is pressed. Backlight sets off within 40 seconds of last key pressed.

## **9. Signalling modes of system arming.**

**Service Settings** → **Arming signalling modes**

This menu allows selection of alarm system arming and disarming signalling modes. Use ▲▼ keys to toggle between functions and ◀▶ keys to change setting. OK button saves selection. Exit menu any time with C button without saving selection.

9.1. **Remote: pulses** ↔ **Remote: pulses + SMS if problem** – selecting the first option sets on signal pulses on sirens only. Selecting second option allows pulses on sirens and SMS notification if any problem occurs (\*).

9.2. **SMS: SMS** ↔ **SMS: pulses + SMS if problem** – selecting first option a return SMS is send on SMS arming. Selecting second option sets on pulses only and SMS notification is received only if problem occurs (\*).

9.3. **CLIP: SMS** ↔ **CLIP: pulses + SMS if problem** – selecting first option a return SMS is send on CLIP arming. Selecting second option sets on pulses only and SMS notification is received only if problem occurs (\*).

9.4. **Loud internal pulses** ↔ **Pulses on OUT1+quiet internal** – selecting first option sets on arming pulses on internal siren only. Selecting second option sets on pulses on external siren connected to OUT1 along with quieter pulses signalled on internal siren.



9.5 **Pulses on WSS** - setting on arming signal pulses on wireless Elmes WSS siren.

(\*) While system arming violation of a zone may occur. Depending on whether the zone is "bypass" type (see 3.1.g), the system will arm and SMS notification will be send informing of the bypassed zone/s or, if the zone is not "bypass" type, the system will not arm and SMS notification will be send with information of violated zone/s.

## 10. System Status

10.1 **Service Settings** → **Status** → **GSM signal level**

Horizontal bar graph display of mobile signal strength as received by GSM module in the CB32G control panel. Strength level weaker than indicated by four bars only is insufficient and control panel placement should be changed.

10.2 **Service Settings** → **Status** → **Elmes Elektronik CB32G ver. X.XX**

Displays installed firmware version of CB32G control panel.

---

## SETTINGS RESET

---

### Resetting password of user number 1.

If user no 1 is disabled or its password is lost and there is no way to enter Service Settings menu of the control panel, it can be hardware enabled and have factory password "0000" restored, in the following way:

1. Open the panel's cabinet (sabotage alarm may occur), disconnect AC power and remove batteries.
2. Short circuit two points R marked (in the upper right corner of the panel board).
3. Connect power supply or insert batteries and then disconnect shorted R points. User no 1 is now enabled and its password is restored to "0000", zones 31 and 32 are disabled and anti-sabotage protection control of OUT1 set off. All other settings remain unchanged.

### CB32G restore to factory settings (default settings).

Factory (default) settings are restored according to procedure described below. The procedure restores factory settings deleting all wireless devices in memory. Records in the event memory are not deleted.

1. Open the panel's cabinet (sabotage alarm may occur), disconnect AC power and remove batteries.
2. Short circuit two points R marked (in the upper right corner of the panel board).
3. While holding down button 3 of the keypad connect power supply – display will show notification: "Factory settings".
4. Release button 3 and wait until control panel restores normal operation.
5. Disconnect shorted R points.

---

## **DESIGNING WIRELESS ALARM SYSTEM**

---

Designing and installation of alarm system with the Elmes Electronic CB32G control panel should start with careful planning of detectors, control panel and outdoor siren placement. To ensure satisfactory protection of secured premises a variety of detectors may be needed. Elmes Electronic PTX50 wireless motion detector and CTX3H or CTX4H wireless magnet contact detectors should be installed in each protected room with window. Additionally, GBX1 wireless glass break detector could be installed for protection of windows breakage in premises and shops. Depending on needs, one or two wired detectors can be connected to parametric EXT and TAMP inputs of the panel. The panel will also operate with RP501 four channel transmitter offering one to four wired detection inputs to be monitored remotely. Learning the RP501 transmitter to the CB32G control panel by activation of input no 4 will learn all four transmitter's inputs to four adjacent alarm zones of the panel. Activating input four of the RP501 while learning the transmitter to zone 20 of the panel will assign four RP501 inputs to alarm zones no 17, 18, 19 and 20. When installing detectors and RP501 transmitter respective instruction manuals must be followed.

It is highly recommended that before permanent installation of detectors or control panel operating range tests should be taken to confirm reliable communication of the devices with the CB32G panel. The RF range test allows evaluation of operation range of wireless devices. This function available in Service Settings menu (3.5) and may also be helpful in detecting any interfering radio signals. If signals received by the control panel are weak, there may be a need to relocate installation places of some detectors or the control panel. In the extreme cases, it is recommended that Elmes Electronic TRX signal repeater to be used to ensure proper performance of the alarm system.

Installation place of detectors is determined individually. Access to the control panel should meet specific needs of protected premises but it is not recommended to place the panel next to the door or in place easily accessible. Best suggested way of disarming the alarm system is to activate entry delay from outside of the premises with the use of a remote. It allows safe opening the entrance door, access control panel keypad to disarm the system with password. The entry delay programmed by an installer or user should allow convenient access to the control panel keypad.

The CB32G control panel may also be installed in place such as bedroom or study room, allowing complete elimination of the entry/exit delay time. In that case, arming and disarming of the alarm system from the outside of premises can be made with the use of a remote or mobile phone. Arming and disarming will be audibly signalled by siren or visually by lamp connected to an output configured to arming and disarming signalling.

The panel features also the option of arming alarm system in the night mode with selected rooms excluded from supervision (e.g. bedrooms, upper floor), as well as the day mode in which only the selected rooms (e.g. cellar, basement, garage) are supervised. Arming entire alarm system, or in night/day modes is done with the use of the CB32G panel keypad. Arming entire system or arming in the night mode only is also possible with the use of remote. All options and functions of alarm system designed with CB32G control panel are user selected and set in the Service Settings menu of the panel.

### **POWERING CB32G CONTROL PANEL**

To ensure proper operation the CB32G control panel requires external AC/DC power supply with 10...20VDC and 1200mA minimum current output.

Initial powering of the panel starts with inserting two 3,7V Li-ION rechargeable batteries (14500 type, AA size) observing indicated polarity and screwing in DC output wires of the AC/DC power pack to +/- terminals of the panel. Plugging the pack to AC outlet backlights the LCD panel and displays software version followed by initial date (day\_month), time (hour: minute: seconds:).

**IMPORTANT!** Use AA size (14500 type) **3,7V LI-ION rechargeable batteries** only with recommended capacity of minimum 600 mAh. The use of other than Li-ION batteries **is not permitted**. Correct battery polarity must be observed when inserting Li-ION batteries. Incorrect battery placement will cause panel damage and repair service will be required. The use of batteries with lower capacity than recommended could not guarantee 24 hours of autonomy operation on AC power failure.

**CAUTION!** Batteries contain dangerous and poisonous substances. Do not dispose of waste batteries with household waste. Dispose waste batteries according to your local recommendations or, ask for disposal instructions your battery supplier.

When operating CB32G connected to wired alarm system with power supply backup does not require Li-ION battery installation and the control panel may be powered by the wired alarm 13,6 VDC auxiliary supply line voltage dedicated to power detectors, sirens, etc.

The CB32G control panel can also be operated without internal Li-ION batteries installed. However, in order to assure its proper operation under AC power failure condition a buffered power supply (ups) should be used. The use of buffered power supply with integral back up battery is best recommended power supply solution.

**NOTICE!** Manufacturer supplies control panel with zone 31 EXT and zone 32 TAMP disabled and anti-sabotage control of output OUT1 set off allowing connection of external siren and power supply to the CB32G panel without activating sabotage alarm. After completing system connections, inserting the batteries and closing panel case, the anti-sabotage protection should be enabled.

### **ALARM SYSTEM WITH ELMES CB32G CONTROL PANEL**

Designed alarm system may be less or more complex depending on individual needs. Simplest alarm may consist of only few detectors and the control panel with internal siren for audible signalling, while complex alarm system would have a range of detectors in addition to internal and external signalling devices.

The diagram presented further shows an example of a complex alarm system with the use of Elmes Electronic PTX50 wireless motion detectors, CTX3H and CTX4H magnet contact (with open & close signalling function) detectors, GBX glass break detector, UBM100H remote control for activating entry delay and panic alarm, wired external siren and CB32G control panel. The system should be power supplied from a dedicated buffered power pack (if external, wired siren is installed) with integral battery backup. If only wireless devices are used in the system, it is sufficient to use control power with AC/DC pack and Li-ION rechargeable batteries. Other advisory examples of alarm configurations with CB32G wireless control panel are shown on Fig.1 and Fig.2.

Wiring of external equipment such as sirens and AC/DC power supply line to the CB32G control panel terminals, should be made through large installation whole and a cable groove in the bottom part of its cabinet. Suggested installation of the control panel is in vertical position, e.g. on the wall at the height of approx. 1.20 to 1.40m, allowing convenient entering keypad commands. The configuration procedure for an exemplary alarm system described further assumes that the user will use a remote control to activate the entry delay. It is recommended to make basic settings, learn detectors and carry out the first tests on workshop table before permanent installation in the premises. Following, are some essential basic steps to be taken at first wireless alarm system configuration setting:

Unpack the CB32G control panel, insert Li-ION batteries (if needed) carefully observing polarity (+/-) marked inside the panel cabinet and connect AC/DC power supply pack. After the control panel initialisation follow steps, as below:

1. Enter Service Settings menu by pressing and holding down OK button (initial password: 0000), and input current date and time (6.1). Enter new password (5.1), the name of the first user and learn remote control transmitter to the user.
2. Unpack wireless detectors: Elmes Electronic PTX50 (motion), CTX3H or CTX4H magnet contacts (opening/closing) and GBX1 (glass break), install batteries and configure according to the included manuals and requirements of the alarm system. Install wired siren or learn dedicated WSS outdoor wireless siren to CB32G panel.
3. Learn detectors to alarm zones of the panel (3.3) and test their operation with the "Alarm detector monitor" function by pressing and holding down button 1 of the keypad until 2 x 16 dots appear representing alarm 32 zones and detectors. For details see ....
4. Set the zone with the entry detector as a „remote delayed" zone (S.S. 3.1.d).
5. Set the entry delay time (6.2) according to individual requirements.

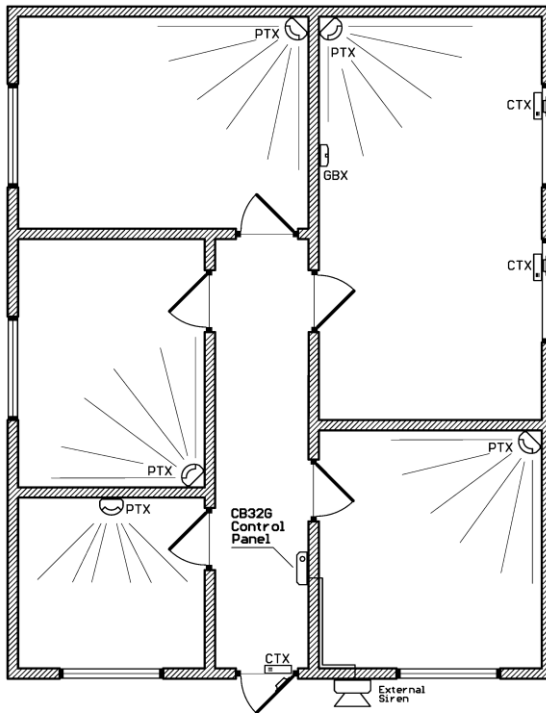

PTX, CTX, GBX  
Elmes Electronic detectors

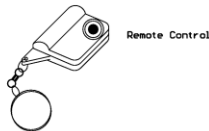

Remote Control

The above steps allow first workshop tests of the constructed alarm system. The CB32G panel's internal siren will audibly signal all alarms and arming/disarming commands. After initial testing the control panel and detectors could be installed in selected places, while checking for the level of the radio signals received from each detector by the control panel ("RF

range test"- see 3.5 of S.S.). Other person help may be needed to activate detectors while the signal level readouts are watched and evaluated.

To enable the anti-sabotage protection against detaching the control panel from wall, the square piece of the backside plastic over the Tamper switch should be removed.

With the system installed and tested in basic configuration, other devices such as an outdoor siren/strobe device can be added. Also, some other functions of the CB32G panel such as anti-sabotage of the OUT1 output (8.4), disable signalling on the internal siren (8.5) or the RF link test between detectors and the control panel, can be defined and set. New users with names (section 5) can be added as well as names of alarm zones can be defined (in 3.2)

## WIRING DIAGRAMS

In a sample installation in Fig. 2, an external wired siren, wireless detectors, wired detectors and buffered power pack (Z1) ensuring operation of the system at AC power failure are used. The power pack supplies power to control panel, external siren and wired detectors. The external siren should be connected to OUT1 alarm output. The OUT 2 output signals the armed/disarmed status while the OUT 3 – failure of 230VAC mains power.

**Figure 1. Basic power supply diagram of CB32G control panel.**

Fig. 1

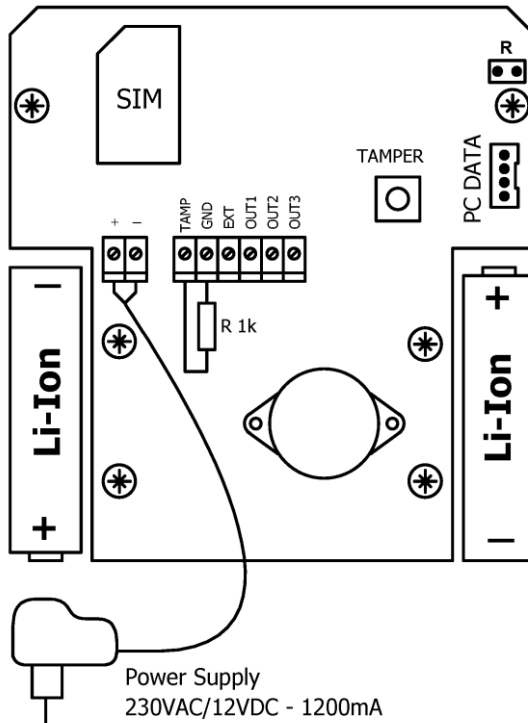

**Figure 2. Sample diagram of alarm installation with a buffered power pack.**

Fig. 2

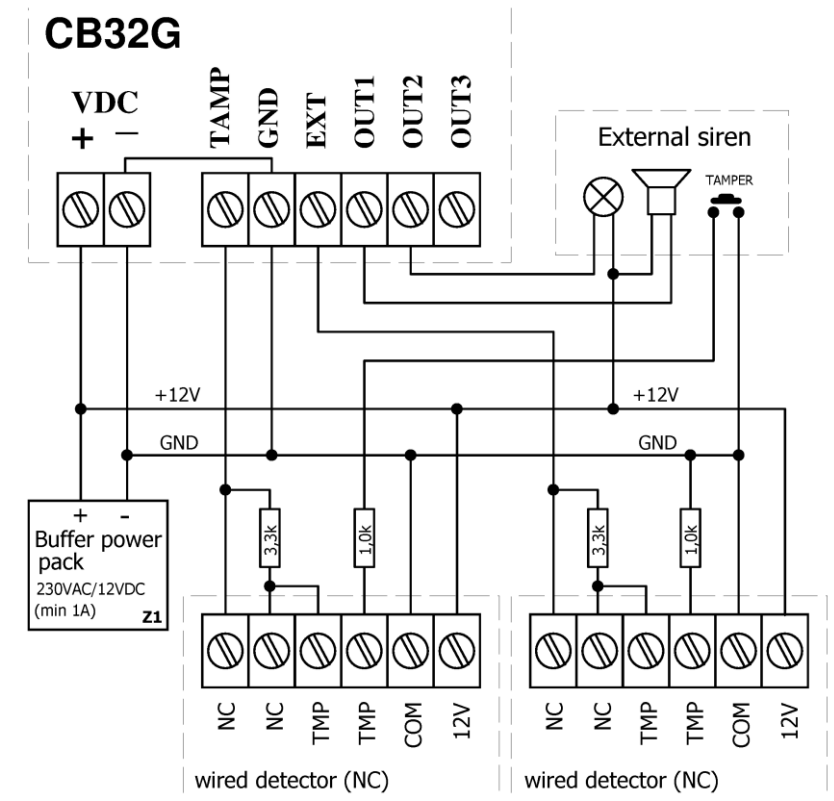

This product complies with the following standards:

1. EN-08390-14:1993 Alarm Systems – General requirements.
2. EN-50130-5:2002 Alarm Systems – Environmental requirements.
3. EN-300 220-3 V1.1.1 (2000-09) Electromagnetic Compatibility and Radio Spectrum Matters.



GSM module: GSM 900 / DCS 1800, Registration No. G110306E, **CE0678**

## SPECIFICATION

- superheterodyne receiver 433.92 MHz, sensitivity better than -102dBm,
- supports up to 32 Elmes Electronic wireless detectors defined as alarm zones,
- supports two wired detectors connected to inputs EXT and TEMP,
- supports up to 16 named users (inclusive of 4 administrators),
- integrated GSM phone module for SMS/CLIP control and notification,

- non-volatile EEPROM memory of last 256 events,
- polymer fuse protected outputs OUT1-3 with up to 1A current draw,
- internal siren/buzzer with alarm sound level - 92dB (at 40cm distance),
- external AC/DC power pack with 9-20VDC and 1200mA rated output,
- backup power with two 3,7V Li-ION rechargeable batteries minimum 600mAh each,
- up to 24 hours autonomy operation with two 600mAh rechargeable batteries,
- external dimensions (without antenna): 110/122/32mm (width/height/thick),
- indoor use only with temperatures range from 0 to +40 °C.

---

**Manufacturer:** *Elmes Electronic, 54-611 Wroclaw, Poland, ul. Avicenny 2,  
phone +48717845961, fax+48717845963, e-mail: elmes@elmes.pl*

---

### **MANUFACTURER'S LIMITED WARRANTY**

The manufacturer of this product warrants the original purchaser that for a period of 24-months as from the date of purchase, the product shall be free of defects in materials and workmanship in normal use. During the warranty period, the manufacturer shall, at its option, repair or replace any defective product upon return of the product to the manufacturer, at no charge for labour and materials. The defective product must be delivered to the point of purchase in a clean condition and at buyer's own expense, along with this guarantee with the date of purchase confirmed below, and a short description of the failure. The cost of dismantling and installing the device is covered by the user. The warranty does not cover batteries and damage arising from improper use or handling, unauthorized adjustments, alterations and repairs.

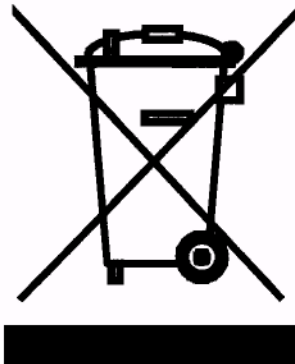

The use of WEEE symbol indicates that this product may not be treated as household waste. By ensuring this product is disposed of correctly you will protect the environment. For more detailed information about the recycling of this product, please contact your local authority, your household waste disposal service provider, shop or supplier where you purchased the product.

---

## FREQUENTLY ASKED QUESTIONS

---

1. ALARM led is flashing. What may be the cause?  
*- enter panel's Menu (press OK for more than 2 seconds) and check for reason. If it is battery failure then check for battery contacts, possible battery leakage or, set OFF battery failure notification (sub-menu 8.6), if batteries are not installed.*
2. ALARM led is lit. What may be the cause?  
*- alarm occurred. Enter Menu and check zone number of the alarm and alarm time or, simply enter and leave the menu, the led light sets off.*
3. Why occasionally sabotage (tamper) alarm is notified in zone 30?  
*- the reason is radio band jamming occurring in the area of panel installation. The jamming may be incidental or deliberate. User may set OFF the radio jamming protection function in sub-menu 8.2 of aux functions however, the entire wireless alarm system is not protected then against deliberate jamming of used radio band and burglary may not be notified.*
4. Why sabotage alarm in zone 32 is set on after connecting power supply?  
*- the reason is panel's tamper switch not properly functioning. Check if plastic element protecting switch arm is removed. If not remove it and adjust its arm by gentle bending to signal the panel being moved off wall, or place of installation. Use washer to adjust proper distance of switch arm from wall. The other reason of the alarm may be lack of 1kOhm resistor in sabotage protection circuit (input TAMP).  
*- sabotage protection of OUT1 is set on (pt. 8.4) and no siren is connected to this output or, wires to the siren are cut off.**
5. Despite CLIP call rejection, control panel calls three times with CLIP call notification ?  
*- in case of some mobile phone operators reaction to call rejection is "call recipient unavailable, please try later..." lasting up to 20 seconds. Only after then the control panel receives information that the call was rejected. Sometimes it is too late and the panel has already disconnected as the CLIP notification time has lapsed. This, in consequence, launch next connection attempts by the panel. To solve the issue, calling time should be prolonged at pt. 7.4 to 30-35 seconds or, calling recurrence set to OFF at pt. 7.10.5*
6. Why the control panel does not respond to wireless detectors signals despite they are programmed to the panel?  
*- it may be due to the fact that the detectors were programmed to the panel with the use of TAMPER switch triggering radio transmission. New programming of the detectors to the control panel should be made with radio transmissions triggered according to the procedures described in manuals of the detectors.*
7. Control panel does not send SMS notifications? Possible causes:  
*- newly used SIM card in CB32G is not initialised. To initialise a new card install the card in any mobile phone and make a call or send SMS first;*  
*- no event is assigned to SMS notification. Select events, e.g. arming, alarming, etc., to be notified by SMS in pt. 5.6 of CB32G manual;*  
*- daily limit of set SMS notifications has been exceeded. To increase the limit change setting in pt. 7.2 or 7.3 or wait till 12.00 hours for new daily limit count.*