



Protec Algo-Tec™ 6400 Interactive Digital Addressable Fire Control System

Protec

Protec Fire Detection plc

Protec Algo-Tec™ 6400

INTERACTIVE DIGITAL ADDRESSABLE

FIRE CONTROL SYSTEM

The Protec Algo-Tec™ 6400 Interactive Digital Addressable System unwrapped:

The Protec Algo-Tec™ protocol developed by Protec's in-house Research and Development team is utilised by the Protec Algo-Tec™ 6400 interactive digital addressable fire control system. Immunity to false alarms, more responsive fire detection, and ease of use has all been achieved to develop one of the most reliable systems available.

Protec Algo-Tec™ 6400

The name Algo-Tec™ is a derivative of Protec algorithms. Algorithms are logical mathematical procedures for solving problems. Protec have developed fire detection algorithms coupled with fuzzy logic specifically designed to reduce unwanted fire alarms and to enhance the sensitivity of the system to true fire phenomenon.

The Algo-Tec™ algorithms are exclusively utilised by the Protec Algo-Tec™ 6400 and 6300 Interactive Digital Addressable Fire Control Systems.

Interactive

Algo-Tec™ evaluates the data of each fire sensor and is able to learn from the information received. This may simply be to recognise that a sensor is becoming contaminated or in a dirty environment and to automatically adjust the alarm threshold to compensate for the background levels (Threshold Compensation).

More complex Algo-Tec™ functions include the ability to discriminate between certain fire and non-fire conditions, filtering out certain environmental stimuli, such as steam from a hotel bathroom, and increasing the sensitivity of a sensor when an increase in temperature is detected.

The net effect of the interaction between the sensors and the Algo-Tec™ decision making is enhanced performance, through immunity to false alarms and more responsive fire detection.









Digital Addressable

The data communication between the sensors and the control equipment is Digital. The Algo-Tec™ protocol utilised by the 6400 system enables high levels of data to be transferred, providing far more detailed information than was previously achievable with analogue addressable systems. It should however be noted that some analogue addressable systems use digital communication but do not transfer the high levels of data associated with the Algo-Tec™ protocol.

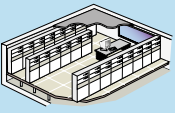
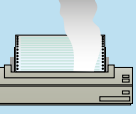
Speed, stability, excellent EMC and security all serve to enhance the Algo-Tec™ Digital signalling. Why select analogue addressable when you can now choose Algo-Tec™ Digital Addressable?

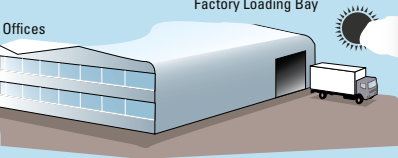
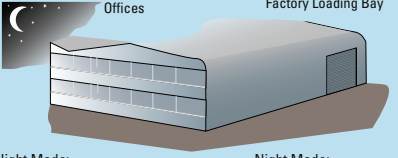

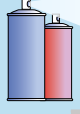
Algo-Tec™ 6000PLUS Interactive Decision Making Algorithms - Typical Applications

<p>Office Mode (High Performance)</p>  <p>DISCRIMINATING ALGORITHM Cigarette Smoke</p>  <p>ALARM Computer Fire</p>  <p>ALARM Bin Fire</p>	<p>Clean Mode (Extra High Performance)</p>  <p>ALARM Computer Room Fire</p>  <p>ALARM Printer Paper Fire</p>  <p>ALARM Chemical Fire</p>
<p>Day/Night Mode</p>  <p>Offices Factory Loading Bay</p> <p>Day Mode: Office mode (high performance) Heat detection only (6000PLUS/OPHT)</p>  <p>Night Mode: Clean mode (Extra high performance) Smoke & Heat detection</p>	<p>Bedroom Mode</p>  <p>DISCRIMINATING ALGORITHM Steam From Bathroom</p>  <p>DISCRIMINATING ALGORITHM Aerosols in Bedroom</p>  <p>ALARM Smoldering Fire</p>

NOTE: The above examples give an indication of system reaction to intermittent contaminants and typical fire sources in a correctly designed BS5839 system. They by no means detail the full complexity of the systems decision making algorithms. Examples are for 6000PLUS/OPHT.

Typical 6400 Network System

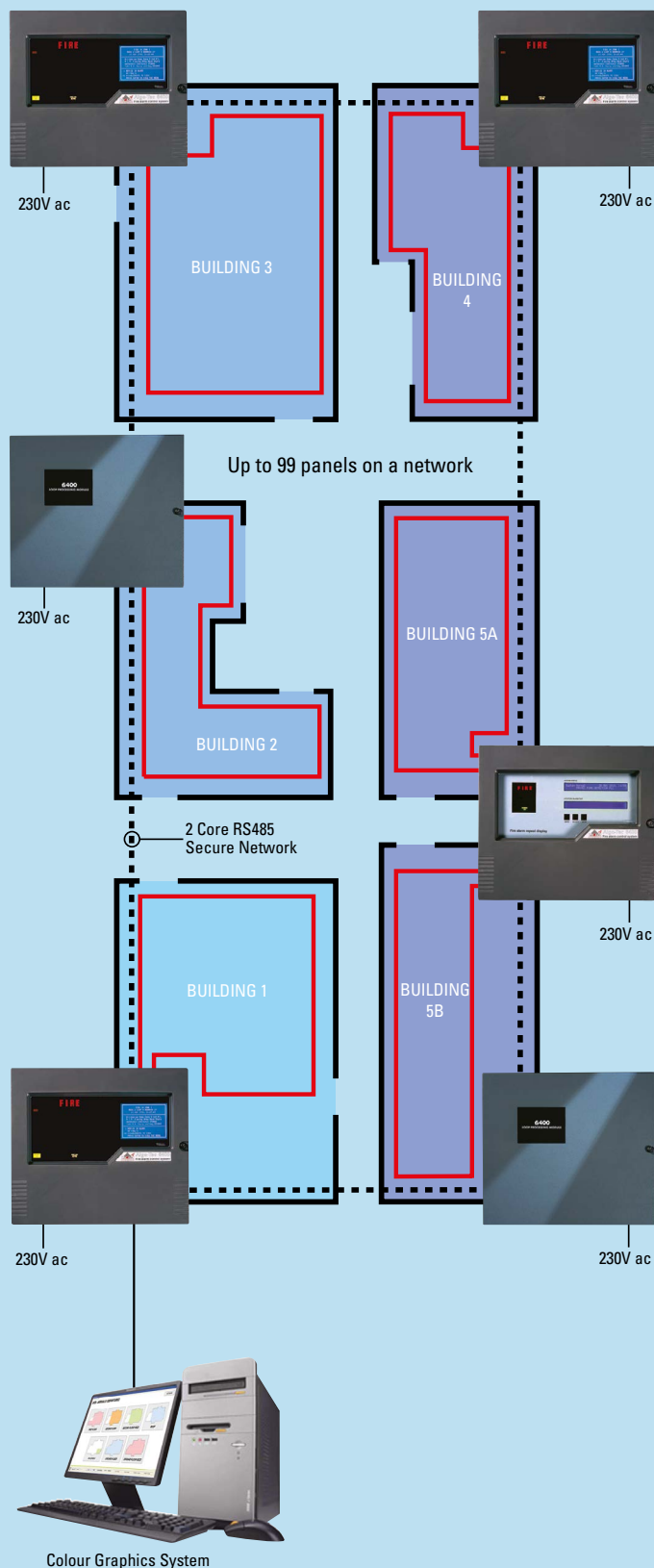

FEATURES & BENEFITS

- **Cost Effective** - Distributed network of Display and Control Nodes (DCN's) and Loop Processing Nodes (LPN's) providing a cost effective solution for medium and large sized buildings and sites.
- **Secure Network** - Wired as a loop, the network's dual channel RS485 link ensures that no single fault will affect the system.
- **Easy To Install** - Alarm Sounders, Visual Alarm Devices, Interfaces, Manual Call Points and Sensors can all be loop powered.
- **Reduced False Alarms** - The Protec Algo-Tec™ 6000 interactive fire sensors utilise advanced discriminating algorithms for maximum reliability and immunity to false alarms.
- **Enhanced Performance** - The Protec Algo-Tec™ 6000 sensors learn from their environment, applying interactive decision making algorithms to provide stability, threshold compensation and optimised performance.
- **Secure Detection Loops** - Many Protec Algo-Tec™ 6000 devices incorporate built-in short circuit isolator units. These can be located as required.
- **Easy to Address** - FAST™ (Firmware Addressed Secure Technology) ELIMINATES troublesome and time consuming setting of address cards and DIL switches.
- **Devices Display Address Number** - 'RVAV' Remote Visual Address Verification. Confirmation of the correct location of each device can be easily identified, using the devices in-built LED to indicate the device address number.
- **Accurate Location of Fire Incidents** - 16 characters of loop location text plus 60 characters of device location text ensure pinpoint accuracy of the location of an incident. A further 60 characters of alarm message text provide additional details of possible hazards and /or means of access.
- **Full Site Control** - All system controls and menus can be accessed from any Display and Control Node (DCN) location, including device isolation.
- **On Site Flexibility** - Configuration of all system functions is fully site programmable.
- **Reduced Maintenance Costs** - Early indication and reporting of sensors approaching contamination level, reduce false alarms and enable dirty sensors to be cleaned.
- **True System Management** - As each device incorporates a unique FAST™ serial number encoded during manufacture, TRUE SYSTEM MANAGEMENT is achievable, providing precise DEVICE history in addition to LOCATION history for a specific site system and total traceability of all devices manufactured from our commissioning files for quality management, using optional PC package.
- **Designed to EN 54-2 & 4**

Protec

Protec Fire Detection plc

Protec Algo-Tec™ 6400

INTERACTIVE DIGITAL ADDRESSABLE

FIRE CONTROL SYSTEM

System Features

Overview

The Protec Algo-Tec™ 6400 is a fully distributed, networked interactive digital addressable fire detection and alarm system, ideally suited for medium and large sized buildings such as hotels, offices, universities, hospitals and complex industrial and commercial sites.

Designed and manufactured by Protec, to comply with EN 54-2 & 4, the system architecture has been developed to provide a seamless network of Display and Control Nodes (6400/DCN's) and Loop Processing Nodes (6400/LPN's). The nodes can be located to suit the site structure and for convenience of wiring, enabling the loop and sounder circuit cabling to be wired locally to the nearest 6400/LPN and displayed at any 6400/DCN around the network. This eliminates the problem of routing all the system wiring to one central location, usually in the reception of a building or a security lodge with restricted space or access. The integrity of the system is also increased as the network is secure and an isolated incident cannot render the entire system inoperative.

Secure Network

A 'secure network' interconnects all 6400 node options. The network is seamless with all system status and activities communicated around the network and accessible from any 6400/DCN location. The system 'cause and effect' programming is stored within each 6400/DCN and 6400/LPN node for added security. Wired as a loop the network's dual channel fault tolerant RS485 ensures that no single fault can disable the system. In the unlikely event of multiple faults, each node will continue to function independently. Up to 99 nodes can be connected to the network. As all 6400/DCN's display and control the entire system network there is no need for a 'master' panel as they all perform this function. This further enhances the integrity of the system. The network can be wired using copper or fibre optic cables.

Loops

The distributed nature of the 6400 system enables expansion by adding 6400/LPN Loop Processing Nodes to the system network. 6400/LPN's can be 2 or 4 loops. Each loop can accommodate up to 127 Protec Algo-Tec™ 6000 interactive addressable devices, totalling 508 addressable devices per 6400/LPN and a total network capacity of over 50,000 addressable devices. In addition to sensors, interfaces and manual call points, the loop can also support loop powered SOUNDERS, VISUAL ALARM DEVICE and OPTICAL BEAM DETECTORS. Loop powered sounder bases adopt the sensor address to increase the capacity of the loops still further.

Node Options:

6400/DCN - Display and Control Node

6400/LPN - Loop Processing Node

6400/DCN/LPN - Combined DCN and LPN (2 nodes)

6400/RDN - Repeat Display Node

6400/RDN/LPN - Combined RDN and LPN (2 Nodes)

6400/MIMIC - Illuminated Mimic Node

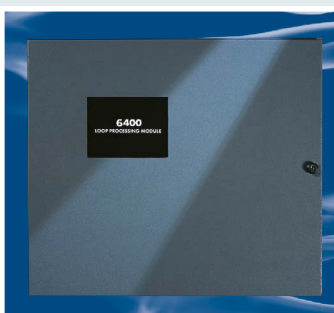

6400/LPN



9000/BC8/24

6400/LPN

The 6400/LPN nodes process the loop data from the field devices, communicate with other network nodes, and implement the cause and effects program for local and network fire signals. Sounder circuits and auxiliary change-over contacts are also controlled from the 6400/LPN.

6400/DCN/LPN

The 6400/DCN and 6400/LPN are combined within a common enclosure. The appearance is the same as the 6400/DCN and uses the 6400/LPN back box to accommodate the cabling.

6400/MIMIC

The Protec 6400 customised illuminated mimic can be connected to the network in the same way as other nodes. The LED indicators can be activated by the appropriate zone or specific device activation as defined and the mimic is available in a range of styles and finishes to suit the application. The 6400/MIMIC is a node on the network.

9000/BC8/24

The 9000/BC8/24 power supply is housed in a similar enclosure to the 6400/LPN and is finished in storm grey. The unit incorporates an 8 amp charger and 24Ah sealed lead acid cells. The charger provides a dual path 24V dc output for parallel supplies to the 6400/LPN or 6400/DCN nodes. A short circuit fault on one path is isolated and the load is provided via the second supply path. Power on and charger fault indications are displayed on the power supply "secret until lit" display and are also relayed to the 6400 network via the node being powered. A range of Protec 9000/BC power supplies are available with an extensive range of battery and charger sizes.



6400/DCN Overview

Display and controls of the Algo-Tec™ 6400 system are via 6400/DCN's. All the functions of the 6400/DCN are accessed via a modern styled hinged lockable door, moulded from polycarbonate, finished in storm grey with a clear display viewing window, optional polished solid brass or brushed stainless steel finishes for recess mounting only. When opened, the door allows access to the system controls. These controls are SOUND ALARMS, SILENCE, ACCEPT and RESET push buttons plus a qwerty membrane keypad and arrow keys to enable access to the user menu facilities.

The display consists of a quarter VGA graphics LCD with backlight, common 'FIRE' indicator, 100 separate zonal fire LED's, power on, pre-alarm, supply fault, alarms silenced, system fault, print, alarms on, outputs disabled, fire link disabled, test, fault, alarm fault, fire link active, fire link fault, fire link delay, output delay & a 'print on demand' 40 column low noise thermal printer. Two full duplex RS232 ports that are site configurable for baud rate/handshaking are available for site programming and interfacing to BMS, Colour Graphics or Pager systems.

Liquid Crystal Display

The 6400/DCN incorporates a quarter VGA backlit graphics LCD. In normal conditions the date and time is displayed and 'system status: normal'. During a fire event the LCD will display the following:-

- Zone Number in Fire
- Loop Location Text (16 Characters)
- The Device Number in Alarm
- Date and Time of Incident
- Device Location Text (60 Characters)
- Device Alarm Message Text (60 characters)
- Number of devices in alarm

The LCD also displays all faults, disablements, pre-alarms, user menus, past events and analogue values graphically in a bar graph.

Zones

The 6400/DCN has 100 separate secret until lit zonal fire LED indicators. Each addressable device can be allocated to any one of the 100 zones. Expansion panels are available to expand the zonal capacity to a maximum of 800 zones.

Printer

The integral printer is a 40 column low noise thermal printer. In operation the printer will print all system activities on demand detailing the date and time of event; the loop location text, and address number; 60 character device location text; and in alarm conditions, the alarm message text. By accessing the appropriate function from the user menu facility, reports can be printed detailing current faults, current disablements, past events, analogue values, loop devices, fire events or all events from the internal 2000 event historical log.

User Menu

The user menu functions available include:- set time and date, display events, printer menu, disablement menu, test options, text editor menu, clear system fault and access codes. 32 access codes can be configured by entering a 'master user' code. The access codes can be configured to restrict access to certain user menu functions.

The disablement menu enables the user to disable any loop driven device on the 6400 network. When disabled the device is prevented from producing a fire condition on the system. Devices can be isolated by address number, address location text or by zone.

Qwerty Keyboard

The text editor menu function within the 'user menu', enables the user to edit the 60 character 'device location text' and 60 character 'alarm text'. The text is entered using the in-built qwerty membrane keypad on the front of the 6400/DCN.

On Site Programming

Recognising the problems associated with commissioning and maintaining a complex site, the 6400 system is site programmed using dedicated PC based programs. The entire system configuration can be downloaded from any 6400/DCN via the integral RS232 port and distributed using the 6400 network. The programming method not only reduces on site commissioning, but also provides copies of site data as a backup, stored remotely. Hard copies of the programming data can be provided via the PC software.

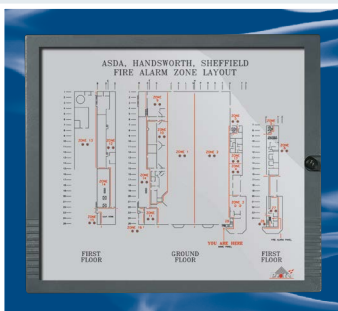

6400/MIMIC

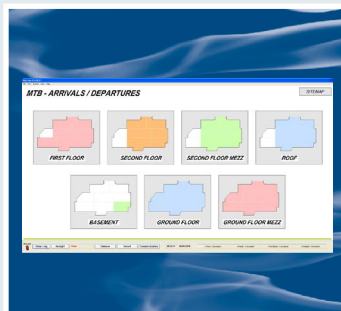

6400 Hercules Colour Graphics System

6400/RDN

The 6400/RDN node has all the functions detailed for the 6400/LCD and additionally has 'silence' & 'reset' push buttons to silence and reset active system fire events. All controls are housed behind a hinged lockable door, moulded from polycarbonate finished in storm grey. The 6400/RDN has an optional printer to print current fire events, fault events or disablements. The 6400/RDN is a node on the network. The 6400/RDN can also be combined with a 6400/LPN in a common enclosure.

6400 Loop Powered LCD Repeat Display

The 6400/LOOP/LCD can be connected directly to the local Algo-Tec™ digital addressable data loop and takes up just one address. The fascia displays power, fire, fault, disablement and more alarms.

Fire and fault events are displayed on the 4 x 40 character LCD display and automatically scroll. A backlight ensures that the events can be read in all lighting situations. Fire events have highest priority and inhibit the display of fault events. A new event initiates the internal buzzer and a mute button allows the internal buzzer to be muted.

Loop standby/Alarm load 75mA.

Protec Colour Graphics System

The Protec Colour Graphics System is a Windows based PC package providing a graphical representation of large sites enabling the precise location of an incident to be readily identified enabling a prompt response. Using a touch screen or mouse, the operator can track an incident and zoom from a site plan to intermediate plan listing floor levels, then zoom to a specific floor plan and if necessary then zoom to a specific detailed area within the floor plan showing the device in question. Colour prints of the maps can also be printed automatically or on demand.

Protec

Protec Fire Detection plc

Protec Algo-Tec™ 6400

INTERACTIVE DIGITAL ADDRESSABLE

FIRE CONTROL SYSTEM

Loop Devices

The Protec Algo-Tec™ 6000PLUS protocol utilises FAST™ addressing (Firmware Addressed Secure Technology). Every FAST™ device is manufactured with a unique serial number. FAST™ addressing ELIMINATES troublesome and time consuming address cards and DIL switching whilst being far more secure than "soft addressing".

The Protec Algo-Tec™ 6000PLUS sensor range has been developed to incorporate advanced fire sensing technology, electronic sounders, high intensity visual alarm and speech enhanced talking sounder capability, all integrated within the sensor head and powered from the loop.

Typical Sensor Variants

- 6000PLUS/OPHT/S = c/w Sounder
- 6000PLUS/OPHT/VAD = c/w Visual Alarm Device
- 6000PLUS/OPHT/S VAD = c/w Sounder and Visual Alarm Device
- 6000PLUS/OPHT/TS = c/w Talking Sounder
- 6000PLUS/OPHT/TS VAD = c/w Talking Sounder and Visual Alarm Device

6000PLUS/HT



FAST™ Interactive Heat Sensor - Interactive addressable heat sensor with low thermal mass thermistor, giving fast response to temperature increases. Other Heat Sensor variants include: 6000PLUS/HT/S, 6000PLUS/HT/SVAD, 6000PLUS/HT/TSVAD

6000PLUS/OP



FAST™ Interactive Optical Smoke Sensor - Interactive addressable high performance optical smoke sensor provide efficient reliable detection using the light scatter sensing principle with rapid response to a fire signal. Other Optical Sensor variants include: 6000PLUS/OP/S

6000PLUS/OPHT



FAST™ Interactive Optical Heat Sensor - Interactive addressable high performance optical smoke and heat multi-sensor. Other Optical Heat Sensor variants include: 6000PLUS/OPHT/S, 6000PLUS/OPHT/VAD, 6000PLUS/OPHT/SVAD, 6000PLUS/OPHT/TS, 6000PLUS/OPHT/TSVAD

6000PLUS/OPHTCO



FAST™ Interactive Optical Heat CO Sensor - Interactive addressable high performance optical smoke heat and carbon monoxide multi-sensor. Other Optical Heat Sensor variants include: 6000PLUS/OPHTCO/S, 6000PLUS/OPHTCO/L, 6000PLUS/OPHTCO/SL, 6000PLUS/OPHTCO/TSL

6000PLUS/BASE



Low Profile Common Mounting Base - Compatible with the above range of Algo-Tec™ 6000PLUS Sensors.

6000PLUS/FFBASE



Fast Fixed Base - Fast fixed recessed base is designed to recess the sensor into a false ceiling to give a lower profile view of the sensor.

6400/LOOP/LCD Repeater



Connected directly to the local data loop and takes up just one address. The 2 x 40 character LCD Display provides clear text location of fire and fault events.

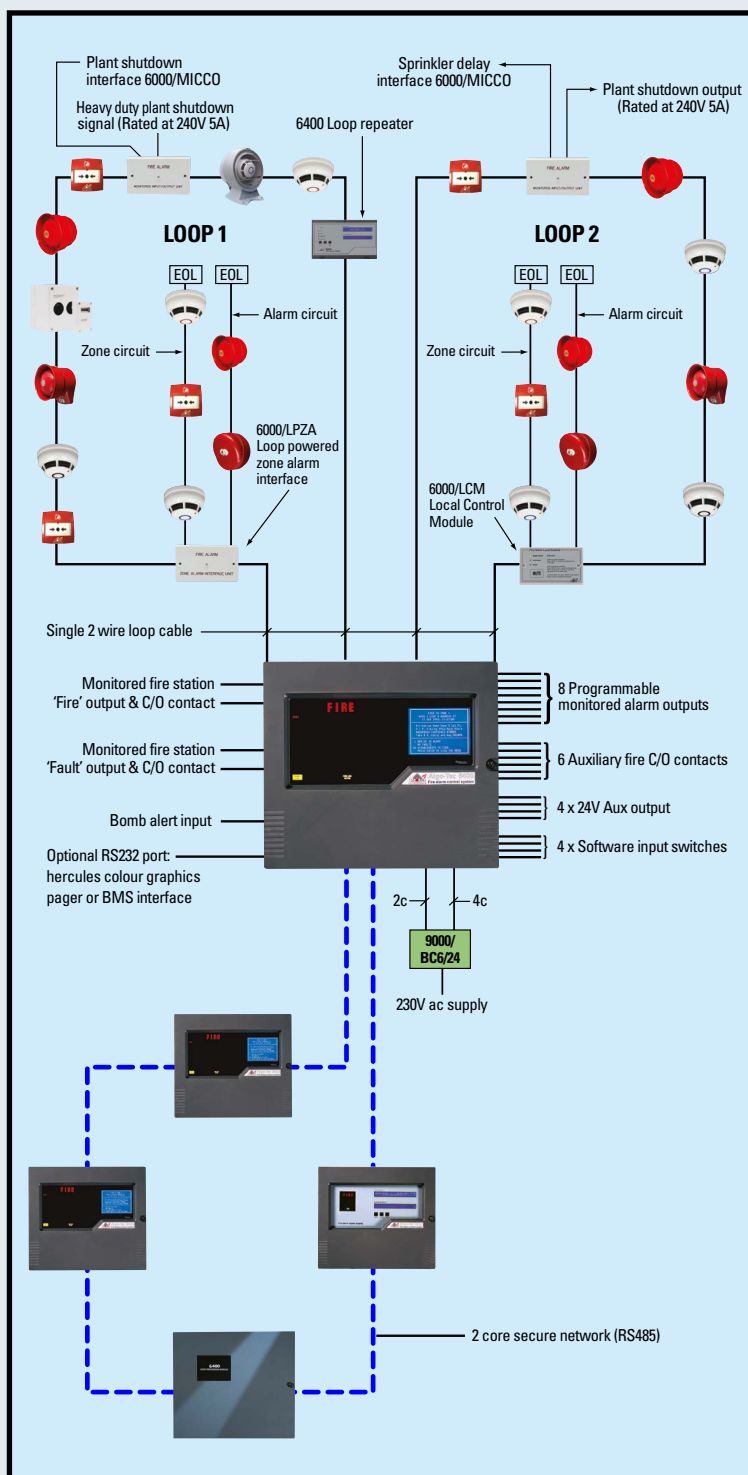

KEY:

- | | | | |
|--|-----------------------------------|--|-------------------------------------|
| | Heat Sensor | | Monitored Input CC Output Interface |
| | Optical Smoke and Heat Sensor | | Electronic Sounder |
| | Optical Smoke, Heat and CO Sensor | | Electronic Sounder VAD |
| | Duct Probe Unit c/w Smoke Sensor | | Visual Alarm Device (VAD) |
| | Manual Call Point | | 6400 Loop LCD Display |
| | Beam Detector | | 6400/DCN |
| | Loop Powered Zone Alarm Interface | | 6400/LPN |
| | Local Control Module | | 6400/RDN |

Guide to loop cable conductor sizing for the Protec 6400 system.

		Loop Length (Metres)														
		500	550	600	650	700	750	800	850	900	950	1000				
Total Loop Load in Alarm (mA)	50															
	100															
	150															
	200															
	250															
	300															
	350															
	400															
	450															
	500															
	550															
	600															
	650															
	700															
	750															
	800															
850																
900																
950																
1000														n/a	n/a	

		Loop Length (Metres)													
		1050	1100	1150	1200	1250	1300	1350	1400	1450	1500				
Total Loop Load in Alarm (mA)	50														
	100														
	150														
	200														
	250														
	300														
	350														
	400														
	450														
	500														
	550														n/a
	600									n/a	n/a	n/a	n/a	n/a	n/a
	650						n/a	n/a	n/a	n/a	n/a	n/a	n/a	n/a	n/a
	700					n/a	n/a	n/a	n/a	n/a	n/a	n/a	n/a	n/a	n/a
	750		n/a	n/a	n/a	n/a	n/a	n/a	n/a	n/a	n/a	n/a	n/a	n/a	n/a
	800	n/a	n/a	n/a	n/a	n/a	n/a	n/a	n/a	n/a	n/a	n/a	n/a	n/a	n/a
850	n/a	n/a	n/a	n/a	n/a	n/a	n/a	n/a	n/a	n/a	n/a	n/a	n/a	n/a	
900	n/a	n/a	n/a	n/a	n/a	n/a	n/a	n/a	n/a	n/a	n/a	n/a	n/a	n/a	
950	n/a	n/a	n/a	n/a	n/a	n/a	n/a	n/a	n/a	n/a	n/a	n/a	n/a	n/a	
1000	n/a	n/a	n/a	n/a	n/a	n/a	n/a	n/a	n/a	n/a	n/a	n/a	n/a	n/a	

The conductor size required as follows:

□ 1.0mm² □ 1.5mm² □ 2.5mm²

MAXIMUM LOOP RESISTANCE 16 OHMS PER CONDUCTOR

Table detailing the loop standby and alarm load for typical Algo-tec™ 6000 devices.

Product	Description	No of Addresses	Loop Standby Load mA	Loop Alarm Load mA
6000/MCP	Manual Call Point	1	0.45	0.85
6000/FIREBEAM	Loop Beam	1	3.65	7
6000PLUS/HT	Heat Sensor	1	0.2	0.2
6000PLUS/HT/S	Heat Sensor c/w Sounder	1	0.4	5.4
6000PLUS/OPHT	Optical Smoke and Heat Sensor	1	0.2	0.2
6000PLUS/OPHT/S	Optical Smoke and Heat Sensor c/w Sounder	1	0.4	5.4
6000PLUS/OPHT/SVAD	Optical Smoke and Heat Sensor c/w Sounder and Visual Alarm Device	1	0.55	24
6000PLUS/OPHT/TSVAD	Optical Smoke and Heat Sensor c/w Talking Sounder and Visual Alarm Device	1	0.55	25
6000PLUS/OPHTCO	Optical Smoke, Heat, and CO Sensor	1	0.45	0.45
6000PLUS/OPHTCO/S	Optical Smoke, Heat, and CO Sensor c/w Sounder	1	0.45	5.45
6000/VAD/W	Loop Visual Alarm Device	1	0.8	19
6000/SSR	Loop Sounder	1	0.7	5
6000/SSR/VAD	Loop Sounder Visual Alarm Device	1	0.7	24
6000/LCM	Local Control Module	1	0.7	5
6000/MICCO	Monitored Input CC Output	1	0.55	5

Note: The following Loop Parameters should be observed

- 1) The total number of addressable devices should not exceed 127 per loop.
- 2) Add 20mA to total loop alarm load to allow for fire indicator LED's on devices
- 3) The total loop alarm load should not exceed 600mA per loop.

6000/MCP



FAST™ Addressable Manual Call Point - Key operated test facility, a loop short circuit isolator is incorporated.

6000PLUS/UG4DP



Ventilation Duct Smoke Sensor Assembly - Single pipe air sampling unit for air speeds from 0.5 to 20m per sec. supplied with 6000PLUS/BASE suitable for use with 6000PLUS/OP FAST™ interactive optical smoke sensor.

6000/FIREBEAM



FAST™ Addressable Loop Powered Beam Detector - Combined transmitter/receiver unit and separate low level controller. With a beam range of 5-100 metres.

6000/SSR



FAST™ Addressable Loop Powered High Output Electronic Sounder - utilises a Piezo driver unit to enable high sound output and very low current consumption.

6000/VAD/W/RED



FAST™ Addressable Loop Powered High Intensity VAD - Approved to EN54-23 the wall mounted VAD has a unique lens that distributes the white light in a cuboid pattern to achieve 7.5m x 7.5m coverage @ 2.4m high.

6000/VAD/C/RED



FAST™ Addressable Loop Powered High Intensity VAD - Approved to EN54-23 the ceiling mounted VAD has a unique lens that distributes the white light in a cylindrical pattern to achieve 7.5m dia coverage @ 3m high.

6000/SSR/VAD



FAST™ Addressable Loop Powered High Output Electronic Sounder with VAD - Approved to EN54-3, 17 & 23 the wall mounted combined sounder/VAD has a sound output of 100dB(A) @ 1m plus VAD light output of 7m x 7m coverage @ 2.4m high.

6000PLUS/TSR2



FAST™ Addressable Loop Powered Talking Sounder - The 6000PLUS/TSR2 voice enhanced talking sounder is available with seven voice messages plus 'bell' sound in addition to the three fire alarm tones compatible with the Protec range of electronic sounders.

6000/FIU



Flush Mounted Short Circuit Isolator Unit - To isolate a short circuit fault on either the incoming or outgoing loop cables. Suitable for a 30mm deep electrical mounting box.

6000/LPZA



FAST™ Addressable Flush Mounted Loop Powered Zone Alarm Interface Unit - With a monitored detection circuit suitable for use with Protec 3000 series detection devices. Line continuity maintained. Monitored alarm output circuit rated at 24Vdc 50mA max. Suitable for a 45mm deep electrical mounting box. A loop short circuit isolator is included.

6000/LCM



FAST™ Addressable Flush Mounted Local Control Module - Allows easy integration of Protec addressable fire detection systems into houses of multiple occupancy and offers novel features to reduce false alarms. The interface drives a zone of 3000 series detection devices and provides a supply to a local alarm circuit.

6000/MICCO



FAST™ Addressable Flush Mounted Loop Powered Monitored Input, Clean Contact Output Interface Unit - With a monitored input circuit suitable for use with simple switch devices and the output is a clean changeover contact 5amp rated at 240V ac. A link can be cut to provide a 7-second delay to the input. Suitable for a 45mm deep electrical mounting box. A loop short circuit isolator is incorporated.

Multi-way Input/Output Interfaces - A range of 16 way input/output interfaces are available with monitored alarm outputs or clean changeover contacts. All interfaces are FAST™ addressable.



Technical Specification

6400 Series Common Specifications

Temperature Range
Maximum Humidity
Working Voltage
Secure Network

Node Power Supply

Total Node Load

6400/DCN

Standby Load (Mains Fail Condition)
Alarm Load (Mains Fail Condition)
Display
Zones
Printer
Nodes
RS232 Ports
Auxiliary Output Supply
Common Fire Output (fire station)
Common Fault Output (fire station)
Dimensions (mm)
Approvals

6400/LPN

Standby Load (Mains Fail Condition)
Alarm Load (Mains Fail Condition)
Analogue Addressable Loops
Total Loop Load
Nodes
Programmable Alarm Outputs

Auxiliary Output Supply
Common Fire Output (fire station)
Common Fault Output (fire station)
Software Input Switches
Dimensions (mm)
Approvals

6400/DCN/LPN

Overview
Standby load (Mains Fail Condition)
Alarm Load (Mains Fail Condition)
Nodes
Dimensions (mm)
Approvals

6400/RDN or 6400/MIMIC

Standby Load (Mains Fail Condition)
Alarm Load (Mains Fail Condition)
Working Voltage
Nodes
Outputs
Dimensions (mm)

6400/LOOP/LCD

Standby Load (Mains Fail Condition)
Alarm Load (Mains Fail Condition)
Working Voltage
Loop Addresses
Dimensions (mm)

9000/BC8/24

Standby Load (Mains Fail Condition)
Power Supply
Integral Charger
Integral Battery
Dual path output

Supply fault signal
Charger inhibit input
Wiring to 6400 Node
Dimensions (mm)
Approvals

0 - 40°C.
85% Non-Condensing.
21.5 - 30V dc.
Dual channel RS485 fault tolerant communications network for up to 100 nodes.
3 wire loop (2 Data & 0V), maximum 1km between nodes.
Fault monitored dual path 24V dc from 6400/BC range PSU 4 wire plus 2 wire
(2 Primary Power, 2 signals) (2 Sec. Power).
Maximum load to a 6400/LPN or 6400/DCN/LPN is 6A.

210mA.
390mA.
Quarter VGA Backlit Graphics LCD.
100 Zone Fire indicators, plus common 'FIRE' indicator. Expandable to 800.
40 column low noise thermal printer.
The 6400/DCN counts as one node on the network.
Two full duplex RS232 ports for site programming, BMS, Colour Graphics or pager system interfacing.
Two sets of 24V dc output terminals. Total load 1A.
24V dc fully monitored output rated at 20mA. 1K EOL.
24V dc fully monitored output rated at 20mA. 1K EOL.
440(W) x 385(H) x 104(D).
LPCB Certificate No: 201ad/01, EC Certificate No: 0832-CPD-1434, Relevant Standard: EN 54-2.

250mA (2 loop) 310mA (4 loop).
480mA (2 loop) 540mA (4 loop).
2 to 4 loops, each with 127 address capacity per loop. Total 6400/LPN capacity 4 loops, 508 addresses.
600mA per loop including all loop connected devices.
The 6400/LPN counts as one node on the network.
8 monitored 24V dc sounder circuits 1A rated. 47K EOL. 6 non monitored - clean changeover contacts (1A rated @24V).
Expansion modules available to increase alarm output capability. Up to 127 programmable alarm outputs per loop using loop output devices. Total node load 6A.
Four sets of 24V dc output terminals. Total load 1A.
24V dc fully monitored output rated at 20mA. 1K EOL. Dedicated Clean Changeover contacts (1A rated @24V).
24V dc fully monitored output rated at 20mA. 1K EOL. Dedicated Clean Changeover contacts (1A rated @24V).
Class change, bomb alert. Plus four additional non-dedicated inputs for day/night mode, etc.
440(W) x 385(H) x 144(D).
(2 loop) LPCB Certificate No: 201ad/02, EC Certificate No: 0832-CPD-1435, Relevant Standard: EN 54-2 & 4.
(4 loop) LPCB Certificate No: 201ad/03, EC Certificate No: 0832-CPD-1436, Relevant Standard: EN 54-2 & 4.

Combined 6400/DCN and 6400/LPN nodes within a common enclosure. The full specification for a 6400/LPN applies plus DCN controls.
380mA (2 loop) 440mA (4 loop).
770mA (2 loop) 830mA (4 loop).
The 6400/DCN/LPN counts as TWO nodes on the network.
440(W) x 385(H) x 144(D).
(2 loop) LPCB Certificate No: 201ad/04, EC Certificate No: 0832-CPD-1437, Relevant Standard: EN 54-2 & 4.
(4 loop) LPCB Certificate No: 201ad/05, EC Certificate No: 0832-CPD-1438, Relevant Standard: EN 54-2 & 4.

150mA.
220mA.
21.5 - 30V dc from LPN,DCN or local PSU.
The 6400/RDN or 6400/MIMIC each counts as one node on the network.
Local fault clean changeover contacts (1A rated @ 24V).
440(W) x 385(H) x 104(D).

75mA.
75mA.
Loop powered.
1.
360(W) x 215(H) x 47(D).

Complies with EN 54-4.
90mA.
Mains 230V ac nominal +/- 10%.
8A.
24Ah 24V Sealed lead acid.
0/P1 - 24V dc Primary supply. 0/P2 - 24V dc secondary supply.
Output path is automatically switched if a S/C fault is detected.
Communicated to nearest connected 6400 node.
From 6400 node during fire conditions to increase output to 8A.
4 wire plus 2 wire (2 primary power, 2 signals) (2 sec. power).
440(W) x 385(H) x 200(D).
LPCB Certificate No: 201ad/06, EC Certificate No: 0832-CPD-1439, Relevant Standard: EN 54-4.



LPCB ref. no. 201ad

Protec
Protec Fire Detection plc

Protec: Scotland Tel: 0845 456 5390 Fax: 0845 456 5391	Protec: North East Tel: 0845 456 5396 Fax: 0845 456 5397	Protec: Yorkshire Tel: 0845 456 5388 Fax: 0845 456 5389	Protec: Midlands Tel: 0845 456 5398 Fax: 0845 456 5399	Protec: South East Tel: 0845 456 5394 Fax: 0845 456 5395	Protec: South West Tel: 0845 456 5392 Fax: 0845 456 5393
---	---	--	---	---	---

Company Policy is one of continuous improvement, we reserve the right to change specification without prior notice

Protec Fire Detection Plc, Protec House, Churchill Way, Nelson, Lancashire, BB9 6RT

Tel: 01282 717171 Fax: 01282 717273 Web: www.protec.co.uk Email: sales@protec.co.uk