

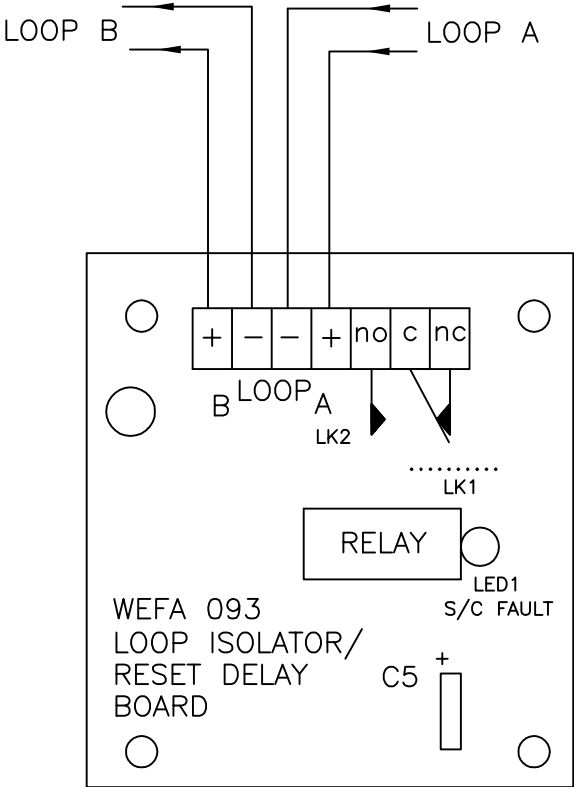

ISSUE	ALTERATIONS	DRAWN	APP'D	MOD No.	DATE
1	FLUSH LOOP ISOLATOR DETAILS ADDED.	SB	JLH	A1908	27.8.96.
2	WIRING CHANGED	SB	JLH	A1910	27.8.96.

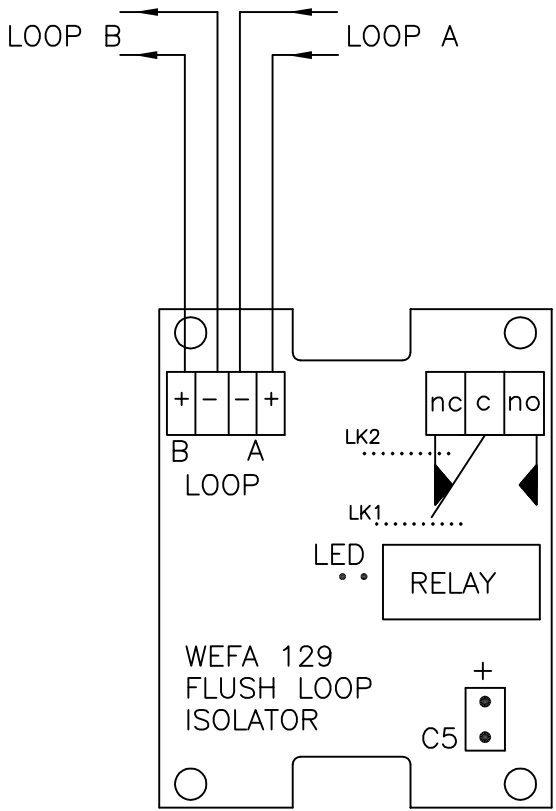

FOR USE AS RESET BOARD  
 1. REMOVE LINKS 1 AND 2.  
 2. WIRE LOOP INTO LOOP A ONLY.

TO ADD RESET DELAY  
 3. REPLACE C5 WITH 1000uF/10V CAPACITOR.

 Protec Fire Detection plc Protec House, Churchill Way, Limeshaye Ind. Est Nelson, Lancashire, U.K. BB9 6RT Tel (01282) 717171 Fax (01282) 717273	SCALE	DESIGNED	
	NTS	DRAWN	S BISCOMB 23.8.96
		CHECKED	R.OLDLAND 23.8.96
APPROVED		L. HARTLEY 23.8.96	
TITLE LOOP ISOLATOR/RESET DELAY BOARD MK3 & FLUSH LOOP ISOLATOR.			
DRAWING No. PID 085			JOB No.
ISSUE	0	1	2